

esbelt

SWAPbelts

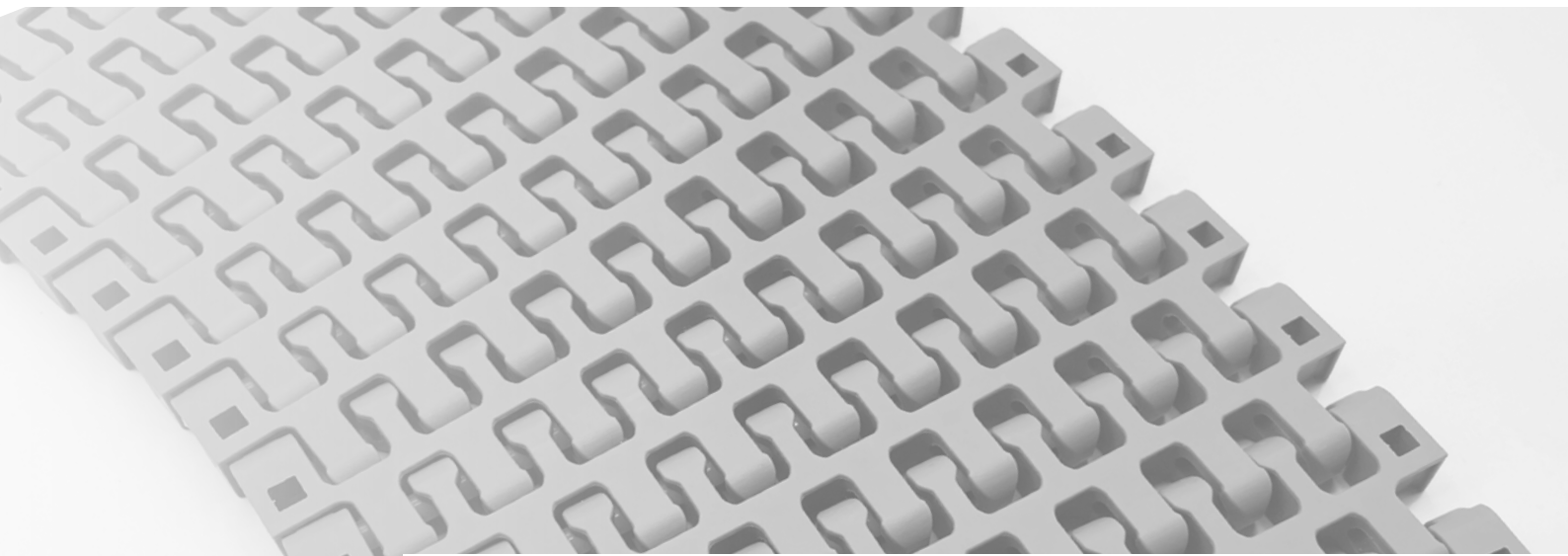

The esbelt Modulares

SWAPBELTS, a conveying system that is flexible and resistant, made to improve industrial efficiency.

Made up of individual and interconnected modules, its design allows for quick and easy replacement in case of partial damage.

These belts are resistant to abrasion, chemicals and extreme temperatures. The uniform belt surface reduces the risk of product damage, ensures safe conveying and improves production efficiency.

Swapbelts modular belts can adapt to different configurations and specific requirements, like attaching flights, sidewalls or other accessories to the belts.

All in all, Esbelt's Swapbelts are another option for increasing productivity and optimizing the conveying and processing of food or materials in demanding industrial environments.

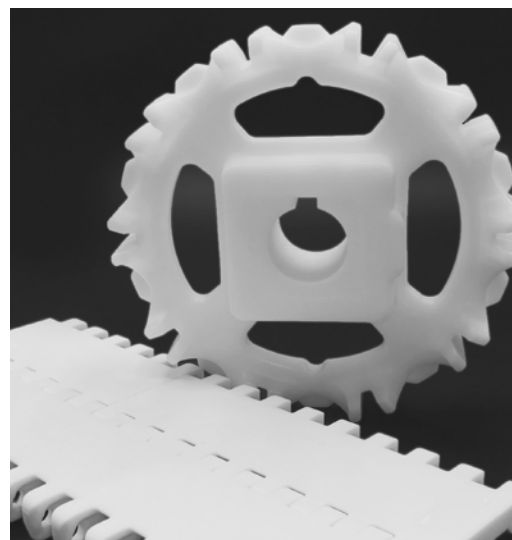
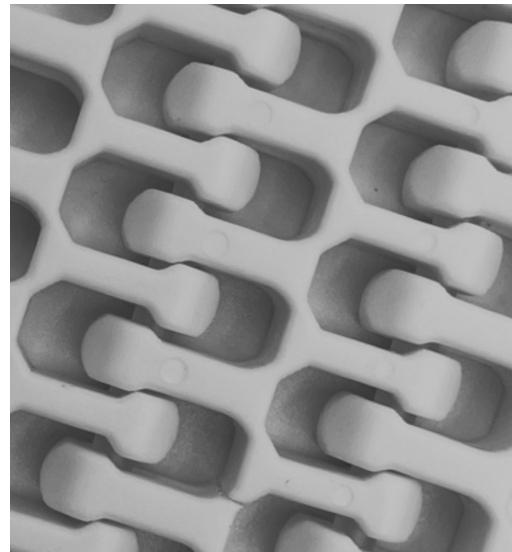

Materials	3
Types	4
Technical data sheets	
F152-11SBE	5
G152-11SBE	7
GC250-5SB	9
F254-2SBV	11
F254-5SB2V	13
GC254-24SB	15
G254-25SB	17
F272-7SBE	19
G272-7SBE	21
G500-36SB	23
F508-1SBVE	25
Installation	27
General tolerances	28

Materials

■ Polypropylene PP

Moderate resistance to abrasion and traction.
 High chemical resistance.
 Not suitable for freezing conditions.
 Good resistance to high temperatures.
 Caution against impacts below +8°C.

■ Polyethylene PE

Limited abrasion resistance.
 High impact resistance.
 Suitable for freezing conditions.

■ Acetal POM

High resistance to abrasion.
 Limited resistance to shocks and impacts.
 Suitable for accumulations.
 Low friction.
 High load capacity.

■ Nylon PA

High resistance to abrasion and traction.
 Not suitable for freezing conditions.
 Good resistance to high temperatures.
 Suitable for heavy, dry and abrasive applications.

Friction table

Material	UHMW	HOPE	Steel	Glass	Stainless steel	Plastic	Card-board	Aluminium
Polypropylene	0,32	0,24	0,15	0,09	0,13	0,08	0,15	0,25
Polyethylene	0,13	0,11	0,26	0,19	0,31	0,16	0,21	0,41
Acetal	0,11	0,09	0,27	0,16	0,26	0,15	0,19	0,28
Nylon	0,18	0,13	0,25	0,16	0,26	0,16	0,19	0,27

Module and rod combination

	Application	Module	Rod
Standard	General dry use General wet use Chemical resistance Low temperature impact High dry load	PP PP PP PE POM	PA POM PP PE PA
Specific for meat	High wet load	POM	HK
Abrasive environment	Cutting at low temperature Dry >60°C Dry >60°C + high load Dry	POM PP POM POM	PE POM HK PA
High temperatures	Dry 60 - 105 °C High dry load T ^a 130° C Food contact > 145°C T ^a > 170° C	PP POM PA PA PA	PP PA PA inox inox

Types

FLAT

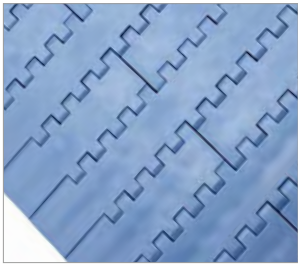

F152-11SBE

Surface: Flat top (0%)
Pitch: 15,2 mm
Straight
FDA & EU

- Food.

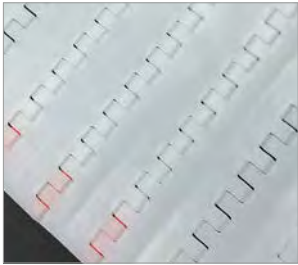

F254-2SBV

Surface: Flat top (0%)
Pitch: 25,4 mm
Straight
FDA & EU

- Meat & poultry processing.

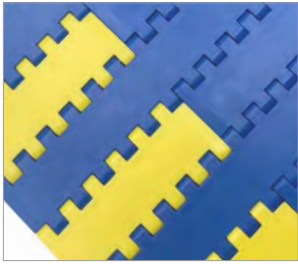

F254-5SB2V

Surface: Flat top (0%)
Pitch: 25,4 mm
Straight
FDA & EU

- Corrugated cardboard.

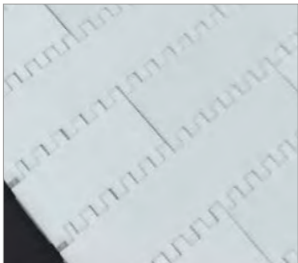

F272-7SBE

Surface: Flat top (0%)
Pitch: 27,2 mm
Straight
FDA & EU

- Automotive industry.
- Bakery.
- Meat processing.
- Cheese processing.

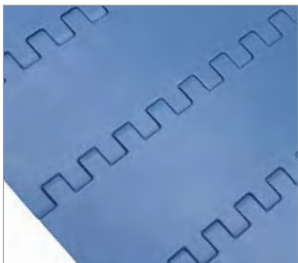

F508-1SBVE

Surface: Flat top (0%)
Pitch: 50,8 mm
Straight
FDA & EU

- Meat & poultry processing.
- Fish and seafood.

GRID



G152-11SBE

Surface: Flush grid (28%)
Pitch: 15,2 mm
Straight
FDA & EU

- Food.
- Canning, bottling, packaging.
- Fruits and vegetables.

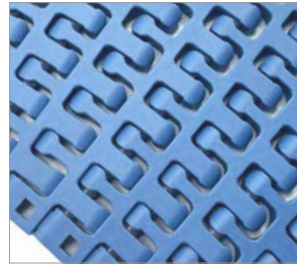

GC250-5SB

Surface: Flush grid (36%)
Pitch: 25 mm
Curve + spiral
FDA & EU

- Frozen bread.
- Cooling lines.

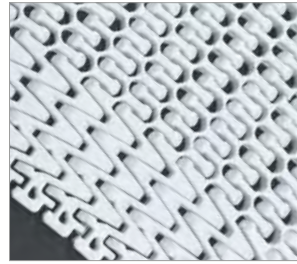

GC254-24SB

Surface: Flush grid (42%)
Pitch: 25,4 mm
Curve + spiral
FDA & EU

- Food.
- Canning, bottling, packaging.
- Pharmaceutical products.

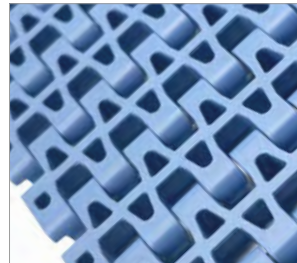

G254-25SB

Surface: Flush grid (31,7%)
Pitch: 25,4 mm
Straight
FDA & EU

- Bakery.
- Fish processing.

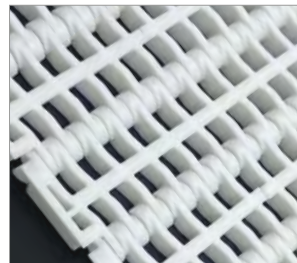

G272-7SBE

Surface: Flush grid (38%)
Pitch: 27,2 mm
Straight
FDA & EU

- Tires.
- Agriculture.

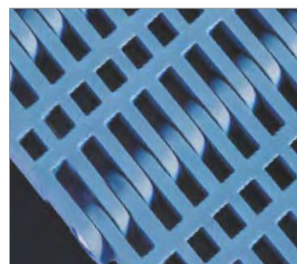

G500-36SB

Surface: Flush grid (27%)
Pitch: 50 mm
Straight
FDA & EU

- Fish and seafood.

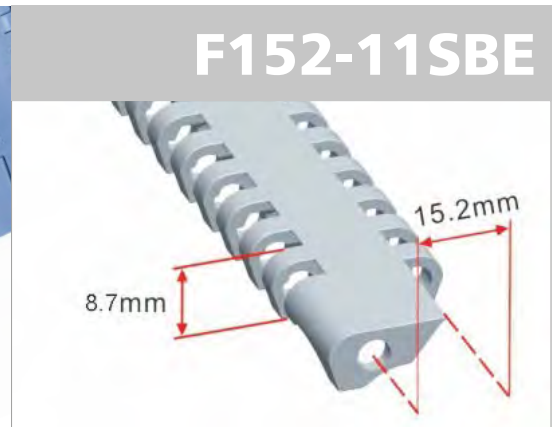
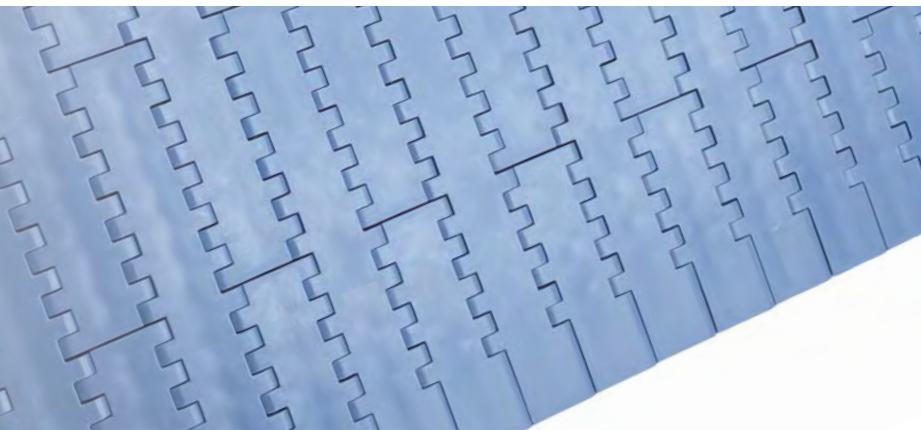

Pitch	Open area	FDA & EU	∅ Rod	Flight	Sidewall	Curve
15,2 mm	0 %	✓	4,5 mm	✓	✗	✗

Material	Color	Resistance of the straight belt	Temperature		Belt weight
		Kg/m width	°C (min.)	°C (max.)	Kg/m ²
Polypropylene PP	BL, WH*	744	1	100	5,2
Polyethylene PE	BL, NT*	450	- 60	60	6
Acetal POM	BL, WH*	1339	- 40	80	7,5

Widths

Modules		Minimum belt width (mm)	Width increments (mm)
Central (mm)	Side (mm)		
152,4	50,8 / 101,6	152,4	25,4



Minimum turning diameter

	Flexing ∅ A (mm)	Back flexing ∅ B (mm)
		25

*Consult availability.

BL= Blue, NT= Natural, WH= White.

Sprockets

N° teeth	∅ pitch PD (mm)	∅ external ED (mm)	Square bore S (mm)	Round bore D (mm)	Width H (mm)	Keyway K (mm)
12	58,73	57,8	25,4 / 27	25,4	22,5	6,35 x 3,17
16	77,91	78	25,4 / 38,1 / 40	25 / 25,4 / 30 / 31,75 / 45	25	6,35 x 3,17
24	116,45	118	38,1 / 40	25,4 / 30 / 31,75 / 35 / 45 / 47	40	6,35 x 3,17
32	155,08	158	38,1 / 40	25,4 / 30 / 31,75 / 35 / 40	40	8 x 8
12-2R	58,73	58,5	25 / 25,4	25 / 25,4	25	8 x 8
16-2R	77,91	78,5	25,4 / 38,1 / 40	25 / 25,4 / 30	25	8 x 8
18-2R	87,53	88,5	25,4 / 38,1 / 40	25,4 / 30	25	8 x 8
20-2R	97,17	97,8	38,1 / 40	25,4	25	6,35 x 3,17
24-2R	116,45	117,7	25,4 / 38,1 / 40 / 50 / 60 / 63,5	25,4 / 30 / 31,75 / 38,1	25	6,35 x 3,17
26-2R	126,10	128,4	38,1 / 40 / 63,5	-	25	-
32-2R	155,08	157	38,1 / 40 / 60 / 63,5	25,4 / 30 / 31,75 / 35 / 40	25	6,35 x 3,17

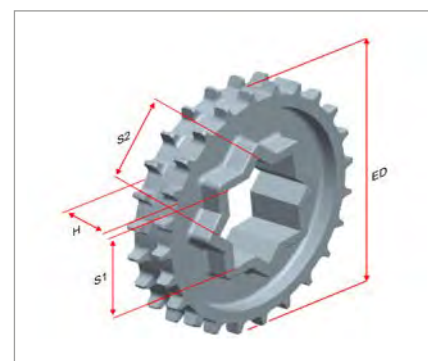
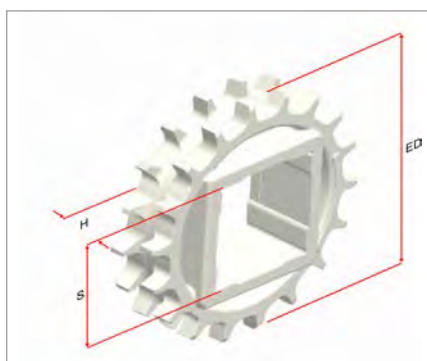
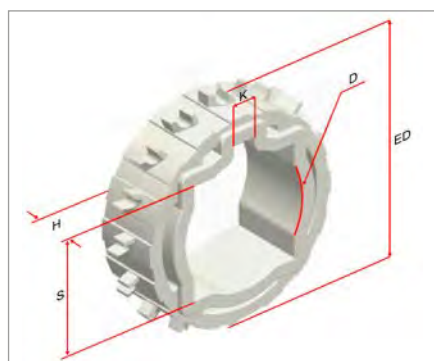

Accessories

Type	Height (mm)	Width (mm)	Molded indent (mm)
Straight flight	50,8	152,4	-

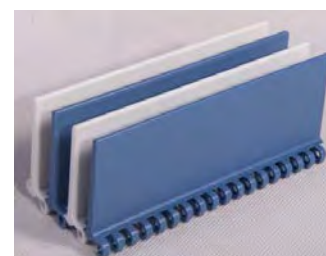

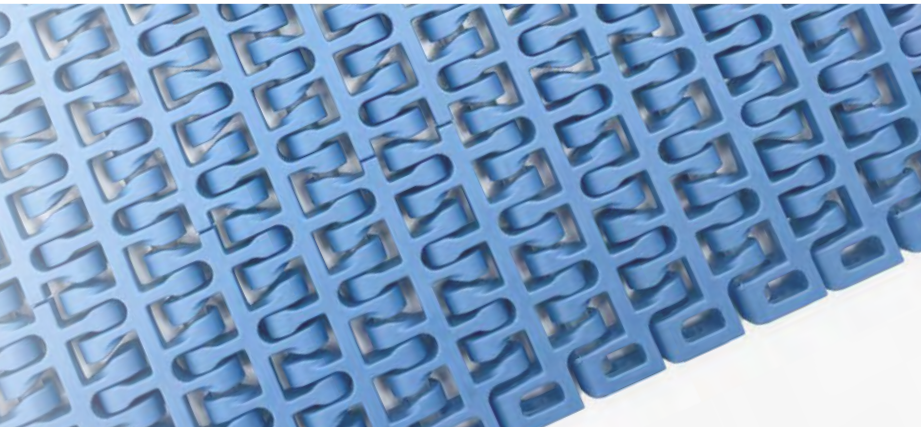

Pitch	Open area	FDA & EU	∅ Rod	Flight	Sidewall	Curve
15,2 mm	28 %	✓	4,5 mm	✓	✗	✗

Material	Color	Resistance of the straight belt	Temperature		Belt weight
		Kg/m width	°C (min.)	°C (max.)	Kg/m ²
Polypropylene PP	BL, WH*	1040	1	100	5,1
Polyethylene PE	BL, NT*	670	- 60	60	5,9
Acetal POM	BL, WH*	1650	- 40	80	7,4

Widths

Modules		Minimum belt width (mm)	Width increments (mm)
Central (mm)	Side (mm)		
152,4	50,8 / 101,6	152,4	25,4



Minimum turning diameter

	Flexing ∅ A (mm)	Back flexing ∅ B (mm)
		25

*Consult availability.
BL= Blue, NT= Natural, WH= White.

Sprockets

N° teeth	ø pitch PD (mm)	ø external ED (mm)	Square bore S (mm)	Round bore D (mm)	Width H (mm)	Keyway K (mm)
12	58,73	57,8	25,4 / 27	25,4	22,5	6,35 x 3,17
16	77,91	78	25,4 / 38,1 / 40	25 / 25,4 / 30 / 31,75 / 45	25	6,35 x 3,17
24	116,45	118	38,1 / 40	25,4 / 30 / 31,75 / 35 / 45 / 47	40	6,35 x 3,17
32	155,08	158	38,1 / 40	25,4 / 30 / 31,75 / 35 / 40	40	8 x 8
12-2R	58,73	58,5	25 / 25,4	25 / 25,4	25	8 x 8
16-2R	77,91	78,5	25,4 / 38,1 / 40	25 / 25,4 / 30	25	8 x 8
18-2R	87,53	88,5	25,4 / 38,1 / 40	25,4 / 30	25	8 x 8
20-2R	97,17	97,8	38,1 / 40	25,4	25	6,35 x 3,17
24-2R	116,45	117,7	25,4 / 38,1 / 40 / 50 / 60 / 63,5	25,4 / 30 / 31,75 / 38,1	25	6,35 x 3,17
26-2R	126,10	128,4	38,1 / 40 / 63,5	-	25	-
32-2R	155,08	157	38,1 / 40 / 60 / 63,5	25,4 / 30 / 31,75 / 35 / 40	25	6,35 x 3,17

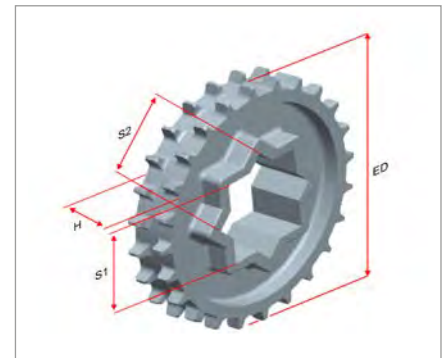
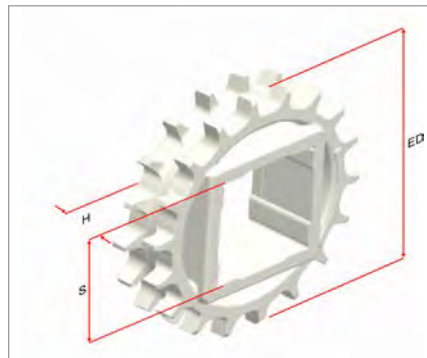
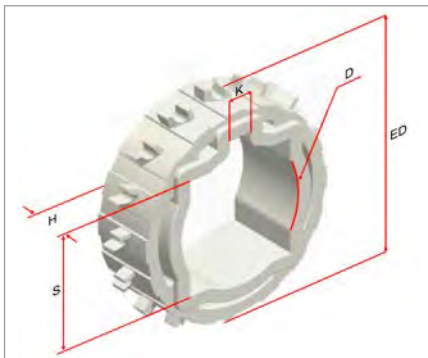

Accessories

Type	Height (mm)	Width (mm)	Molded indent (mm)
Straight flight	50,8	152,4	-

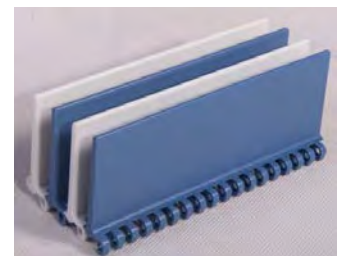

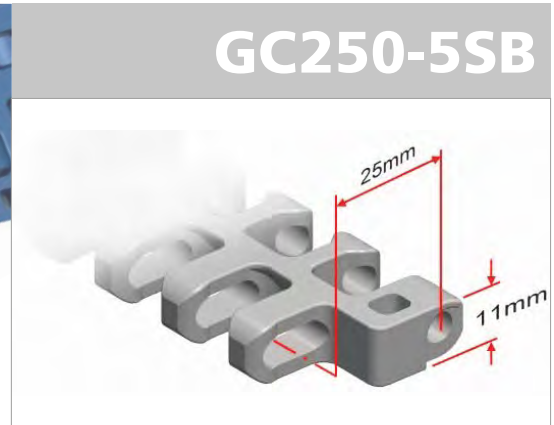
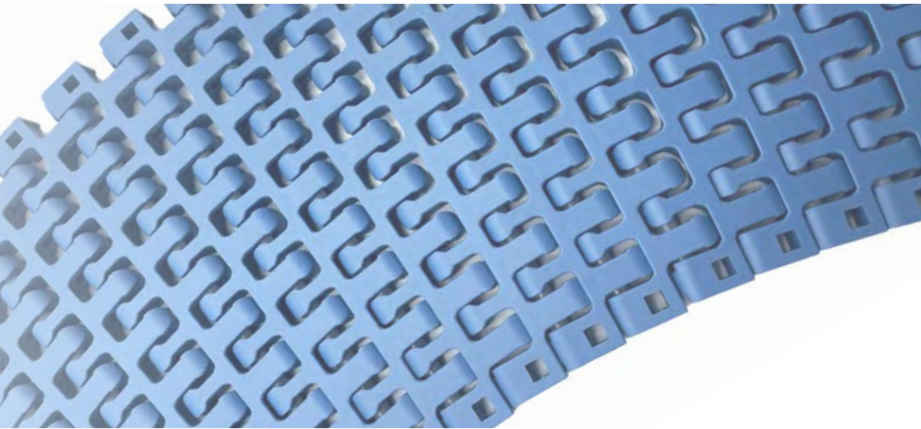

Pitch	Open area	FDA & EU	∅ Rod	Flight	Sidewall	Curve
25 mm	36 %	✓	4,9 mm	✓	✓	✓

Material	Color	Resistance of the straight belt		Temperature		Belt weight
		Straight	Curve	°C (min.)	°C (max.)	Kg/m ²
		Kg/m width	Kg/m width			
Polypropylene PP	BL, WH*	1060	106	1	100	5
Acetal POM	BL, WH*	1720	172	- 40	80	9,6

Widths

Modules		Minimum belt width (mm)	Width increments (mm)
Central (mm)	Side (mm)		
134	165	165	16,75

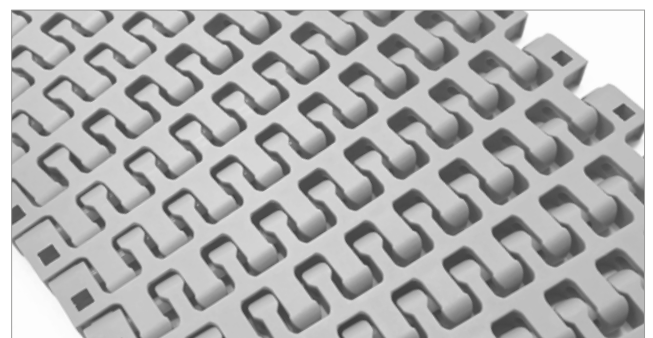
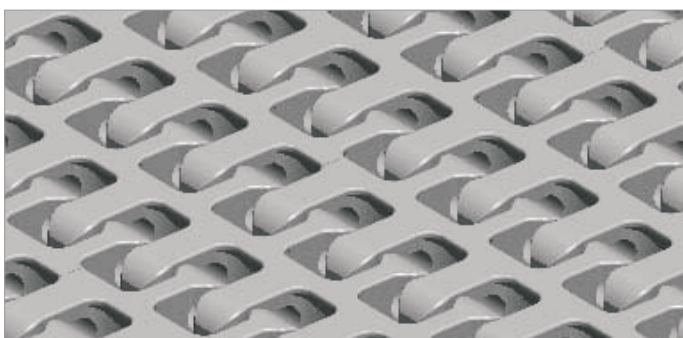

*Consult availability.
BL= Blue, NT= Natural, WH= White.

Sprockets

N° teeth	ø pitch PD (mm)	ø external ED (mm)	Square bore S (mm)	Round bore D (mm)	Width 1 H1 (mm)	Width 2 H2 (mm)	Keyway K (mm)
12	96,59	100	25,4 / 38,1 / 39 / 40	25,4 / 28 / 30 / 31,75 / 35 / 40 / 46 / 47 / 50,8	11 / 18	-	8 x 8
18	143,97	148	25,4 / 38,1 / 40	25,4 / 30 / 31,75 / 35 / 36 / 40 / 45 / 47	18	-	8 x 8
24	191,53	200	38,1 / 40 / 50 / 60	-	30	-	-
8-2R	65,33	64,7	25,4	30	-	20	8 x 8
12-2R	96,59	100	38,1 / 39 / 40	25,4 / 30 / 45 / 47	-	20	8 x 8
15-2R	120,24	125,5	38,1 / 40 / 50,8	25 / 25,4 / 30 / 35 / 38,1 / 40 / 45 / 45 / 47	-	20	8 x 8
18-2R	143,97	148	38,1 / 40 / 45 / 60	25,4 / 30 / 40	-	20	8 x 8
20-2R	159,81	166	38,1 / 40 / 60	25,4 / 30 / 36	-	35	8 x 8
21-2R	167,74	173	38,1 / 40 / 60 / 63,5	45	-	35	8 x 8
24-2R	191,53	200	38,1 / 40 / 60	30	-	35	-

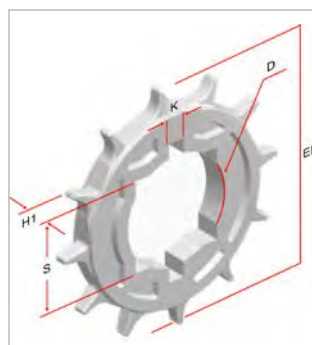

Accessories

Type	Height (mm)	Width (mm)	Molded indent (mm)
Straight flight	50	134	-
		164	20*2
Sidewall	25		

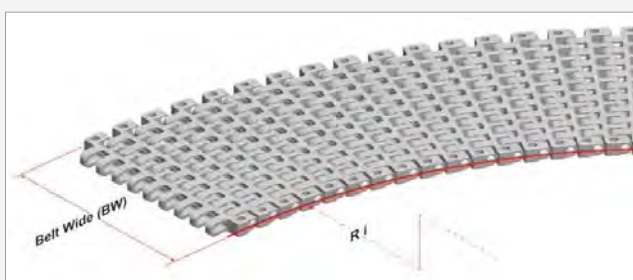

The **minimum** (inside) **turning radius** is 2,2 times the belt width under all feasible belt widths. 2,5 times the belt width is optimal.

The minimum straight section next to the drive and idler shaft of the belt should have a length of 2 times the belt width.

The minimum straight section between two turns of opposite direction should be 2 times the belt width in length.

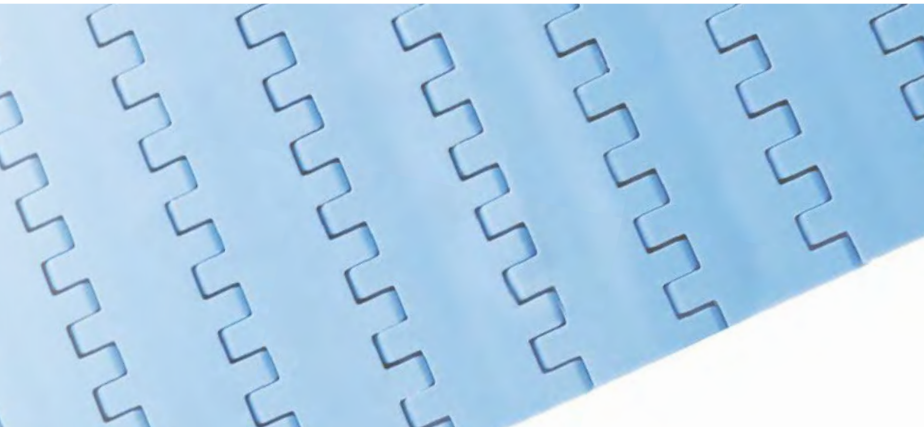

F254-2SBV

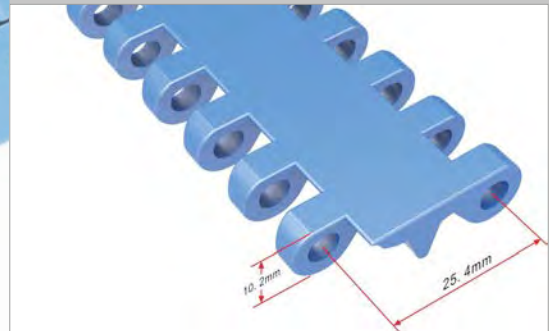

Pitch	Open area	FDA & EU	∅ Rod	Flight	Sidewall	Curve
25,4 mm	0 %	✓	5,3 mm	✓	✓	✗

Material	Color	Resistance of the straight belt	Temperature		Belt weight
		Kg/m width	°C (min.)	°C (max.)	Kg/m ²
Polypropylene PP	BL, WH	1155	1	100	5,6
Polyethylene PE	BL, NT	1105	- 60	60	5,8
Acetal POM	BL, WH	1520	- 40	80	8,9

Widths

Modules (mm)	Minimum belt width (mm)	Width increments (mm)
152,4 / 292,1	152,4	12,7

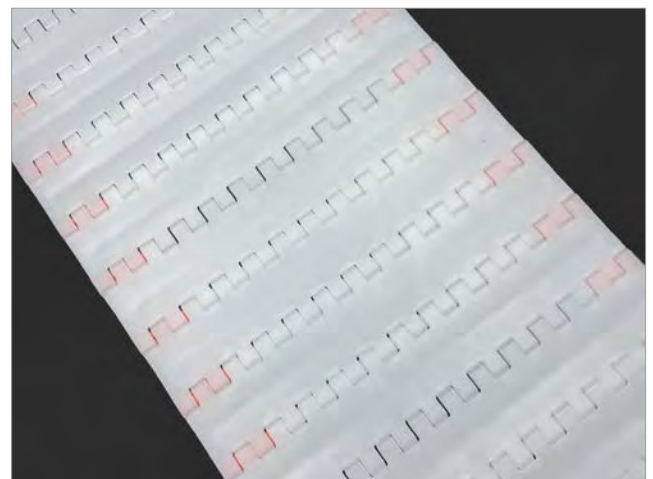
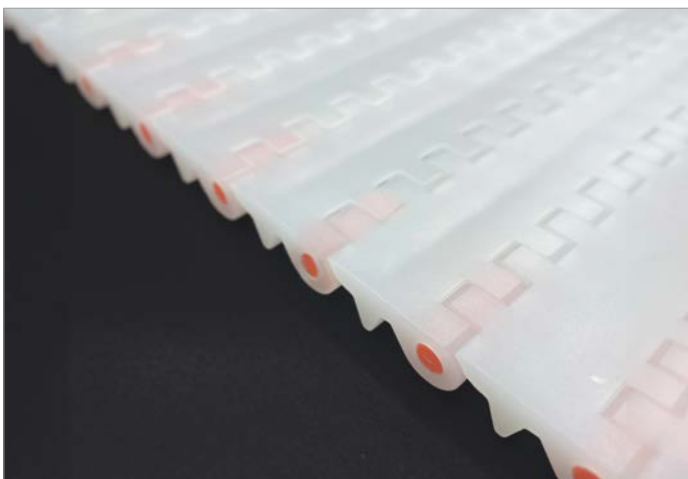
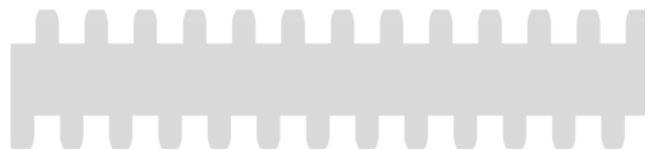

BL = Blue, NT = Natural, WH = White.

Sprockets

N° teeth	∅ pitch PD (mm)	∅ external ED (mm)	Square bore S (mm)	Round bore D (mm)	Width H (mm)	Keyway K (mm)
8	66,37	61	25,4	25,4 / 30	22	6 x 6
10	82,20	79,6	38,1 / 40	25,4 / 38,1 / 45	22	7 x 7
12	98,14	94,5	25,4 / 38,1 / 40	19 / 25,4 / 30 / 31,75 / 45	38	7 x 7
16	130,20	127,4	38,1 / 40	25,4 / 30 / 45	38	7 x 7
20	162,37	160	38,1 / 40	25,4 / 45	38	7 x 7

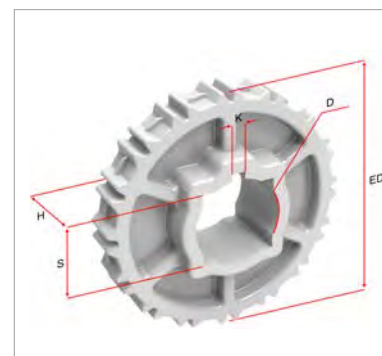

Accessories

Type	Height (mm)	Width (mm)	Molded indent (mm)
Straight flight	25	292,1	22
		152,4	23
	50	292,1	22
		152,4	23
	75	152,4	-
Sidewall	35		
	60		



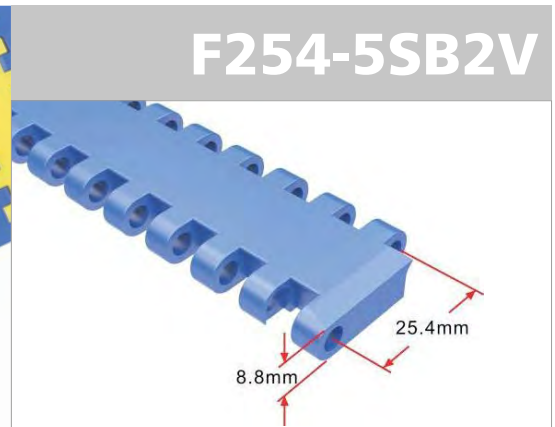
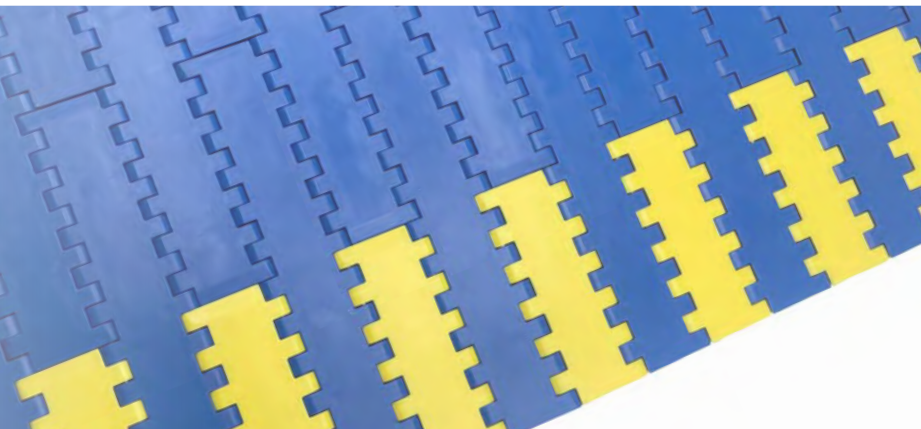

Pitch	Open area	FDA & EU	∅ Rod	Flight	Sidewall	Curve
25,4 mm	0 %	✓	4,9 mm	✓	✓	✗

Material	Color	Resistance of the straight belt	Temperature		Belt weight
		Kg/m width	°C (min.)	°C (max.)	Kg/m ²
Polypropylene PP	BL*, WH*	2000	1	100	5,4
Acetal POM	BL, WH*, YL	3500	- 40	80	8,3

Widths

Modules (mm)	Minimum belt width (mm)	Width increments (mm)
76 / 152	76	76



**Consult availability.*

BL= Blue, NT= Natural, WH= White, YL= Yellow

Sprockets

N° teeth	∅ pitch PD (mm)	∅ external ED (mm)	Square bore S (mm)	Round bore D (mm)	Width H (mm)	Keyway K (mm)
10	82,20	80	38,1 / 40	25 / 25,4	25	8 x 8
12	98,14	96,7	38,1 / 40	25,4 / 30 / 38,1 / 40	25	8 x 8
12-Split	98,14	96,7	38,1 / 40	38,1	25	9,52 x 4,76
15	122,17	121,3	38,1 / 40 / 50 / 60 / 63,5	25,4 / 35 / 40 / 50	29,5	8 x 8
15-Split	122,17	121,3	38,1 / 40 / 50 / 60 / 63,5 / 65	-	33	-
18	146,27	146	38,1 / 40 / 45 / 50 / 60 / 63,5 / 64	25,4 / 30 / 50	25	8 x 8
18-Split	146,27	146	38,1 / 40 / 60 / 63,5	50,8	35	14 x 5
19-Split	154,32	154,5	38,1 / 40 / 50 / 50,8 / 60 / 65	-	35	-
24-Split	194,60	194	60 / 65	-	52	-

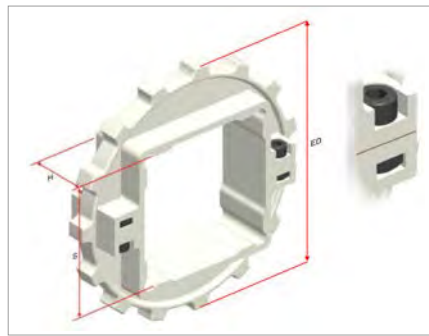
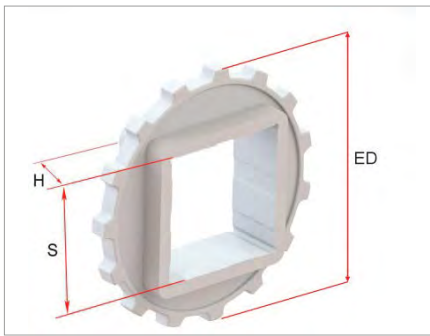

Accessories

Type	Height (mm)	Width (mm)	Molded indent (mm)
Straight flight	10	152	-



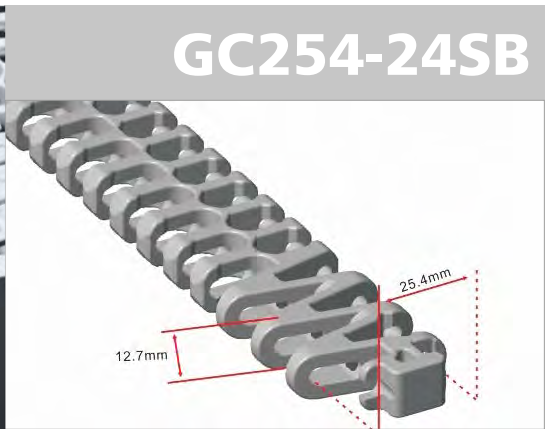

GC254-24SB

Pitch	Open area	FDA & EU	∅ Rod	Flight	Sidewall	Curve
25,4 mm	42 %	✓	4,5 mm	✗	✗	✓

Material	Color	Resistance of the straight belt		Temperature		Belt weight
		Straight	Curve	°C (min.)	°C (max.)	Kg/m ²
		Kg/m width	Kg/m width			
Polypropylene PP	BL*, WH*	890	89	1	100	5,9
Acetal POM	BL, WH	890	89	- 40	80	8,5

Widths

Modules		Minimum belt width (mm)	Width increments (mm)
Central (mm)	Side (mm)		
152,4	123 / 180	303	12,7

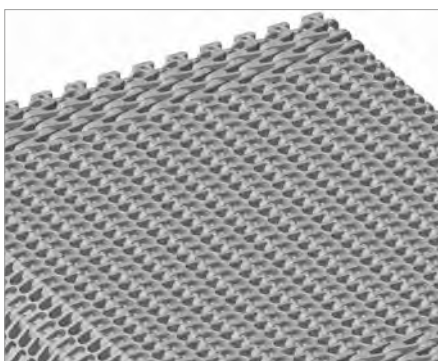

*Consult availability.
BL= Blue, NT= Natural, WH= White.

Sprockets

N° teeth	∅ pitch PD (mm)	∅ external ED (mm)	Square bore S (mm)	Round bore D (mm)	Width H (mm)	Keyway K (mm)
12	98,14	100	25,4 / 38,1 / 39 / 40	25,4 / 28 / 30 / 31,75 / 35 / 40 / 46 / 47 / 50,8	18	8 x 8
18	146,27	148	25,4 / 38,1 / 40	25,4 / 30 / 31,75 / 35 / 36 / 40 / 45 / 47	18	8 x 8
24	194,60	200	38,1 / 40 / 50 / 60	-	30	-
9-2R	74,27	74	25,4	25,4	25	6,35 x 3,17
12-2R	98,14	102	38,1 / 40	-	25	-
16-2R	130,20	132	38,1 / 40	25,4 / 38,1	25	6,35 x 3,17
20-2R	162,37	163	38,1 / 40	25,4 / 38,1	25	6,35 x 3,17

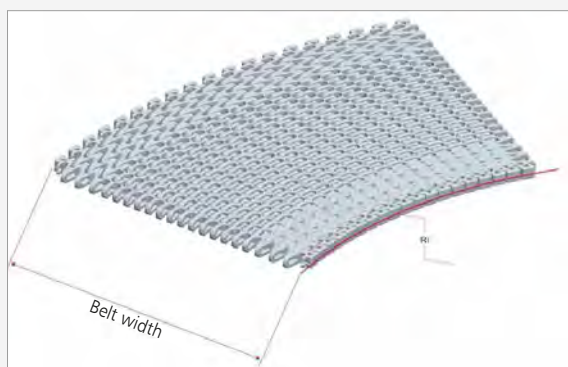
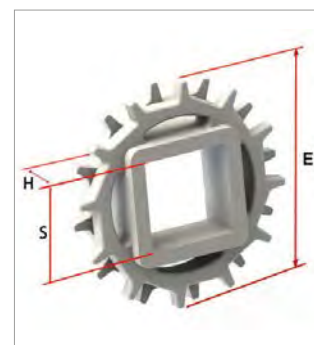
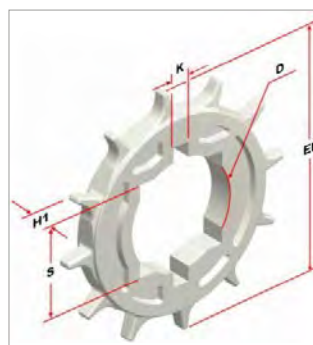

The **minimum** (inside) **turning radius** is 1,7 times the belt width under all feasible belt widths, 2,0 times the belt width is optimal.

The minimum straight section next to the drive shaft and the belt idler shaft should be 2 times the belt width.

The minimum straight section between two turns of opposite direction should be 2 times the belt width in length.

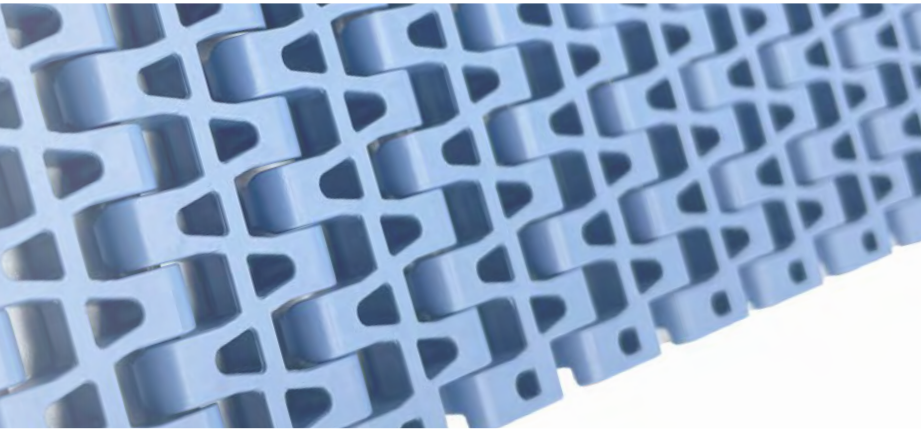

G254-25SB

Pitch	Open area	FDA & EU	∅ Rod	Flight	Sidewall	Curve
25,4 mm	31,7 %	✓	4,9 mm	✓	✗	✗

Material	Color	Resistance of the straight belt	Temperature		Belt weight
		Kg/m width	°C (min.)	°C (max.)	Kg/m ²
Polypropylene PP	BL, WH	1060	1	110	5,15
Polyethylene PE	BL, NT	1030	- 60	60	5,41
Acetal POM	BL, WH	1720	- 40	85	8,15

Widths

Modules	Minimum belt width (mm)	Width increments (mm)
Side (mm)		
50,25 / 100,5 / 201	50,25	16,75

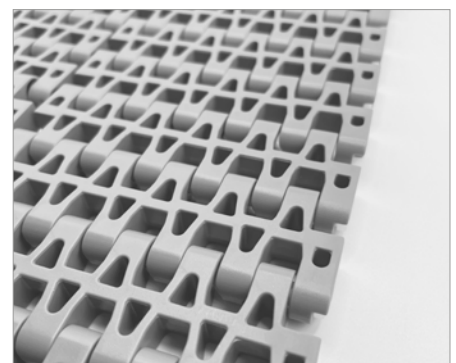
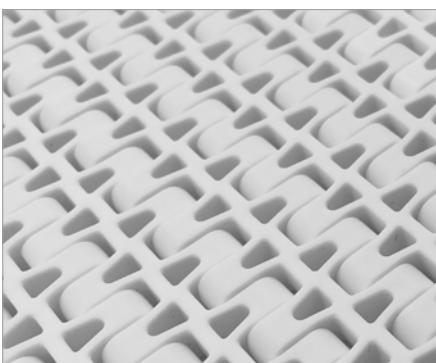

*Consult availability.
BL= Blue, NT= Natural, WH= White.

Sprockets

N° teeth	ø pitch PD (mm)	ø external ED (mm)	Square bore S (mm)	Round bore D (mm)	Width H (mm)	Keyway K (mm)
8-2R	66,37	65,6	-	25,4 / 30	30	8 x 8
10-2R	82,20	82,5	25,4 / 38,1 / 40	25,4 / 30 / 31,75	30	8 x 8
12-2R	98,14	99	38,1 / 40	25 / 25,4 / 30 / 32	20	8 x 8
15-2R	122,17	124	38,1 / 40	25,4 / 30 / 35	20	8 x 8
16-2R	130,20	131,5	38,1 / 40	30	20	8 x 8
18-2R	146,27	148,5	38,1 / 40 / 60	25,4 / 30 / 31,75	20	8 x 8
20-2R	162,37	164,5	38,1 / 40 / 60 / 70	-	30	-
20-2R-Split	162,37	164,5	38,1 / 40 / 60	-	40	-

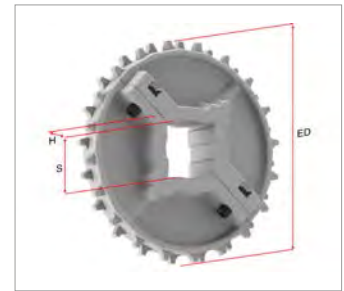
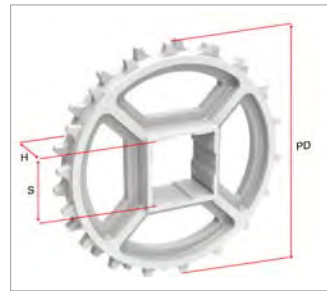

Accessories

Type	Height (mm)	Width (mm)	Molded indent (mm)
Straight flight	25	201	-
	50		
	75		



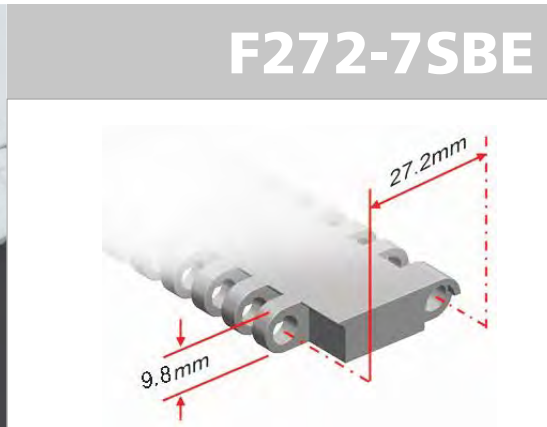

F272-7SBE

Pitch	Open area	FDA & EU	∅ Rod	Flight	Sidewall	Curve
27,2 mm	0 %	✓	4,5 mm	✓	✓	✗

Material	Color	Resistance of the straight belt	Temperature		Belt weight
		Kg/m width	°C (min.)	°C (max.)	Kg/m ²
Polypropylene PP	BL, WH	1340	1	100	4,9
Polyethylene PE	BL, NT*	1060	- 60	60	5,7
Acetal POM	BL, WH	1880	- 40	80	6,8

Widths

Modules		Minimum belt width (mm)	Width increments (mm)
Central (mm)	Side (mm)		
152,4	50,8 / 101,6	152,4	≈ 8,47

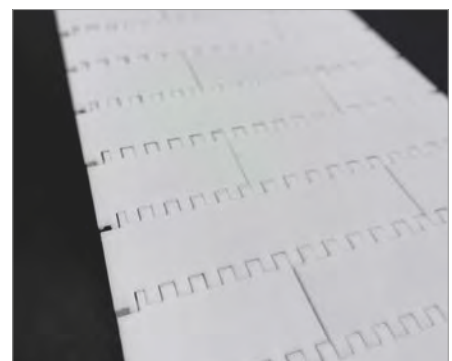
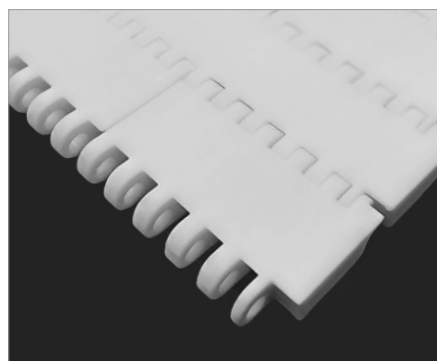
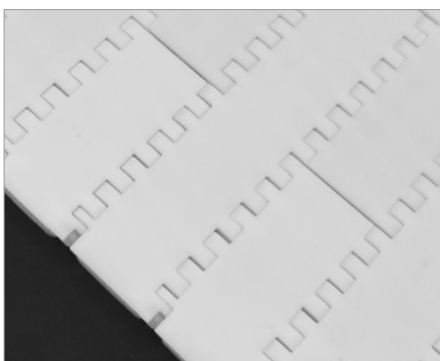

*Consult availability.
BL= Blue, NT= Natural, WH= White.

Sprockets

N° teeth	∅ pitch PD (mm)	∅ external ED (mm)	Square bore S (mm)	Round bore D (mm)	Width H (mm)	Keyway K (mm)
6	54,40	52,3	25,4	-	18,5	-
9	79,53	79,8	25,4 / 38,1 / 40	25,4	21,5	6,35 x 3,17
10	88,02	87,5	25,4 / 38,1 / 40	25,4 / 30	18,8	6,35 x 3,17
12	105,09	105,5	25,4 / 30 / 38,1 / 40	25,4 / 30 / 31,75 / 35 / 38,1 / 45 / 47 / 50	35	6,35 x 3,17
17	148,03	152	-	114	35	4,5 x 4,5
18	156,64	157,8	38,1 / 40 / 50 / 60 / 63,5	25,4 / 30 / 31,75 / 35 / 38,1 / 40 / 46 / 47	35	6,35 x 3,17
20	173,87	175	38,1 / 40 / 60	25,4 / 30 / 31,75 / 38,1	35	6,35 x 3,17
20-Split	173,87	175	60	31,75 / 30	40	6,35 x 3,17
24	208,39	209,8	38,1 / 40	25,4 / 30 / 38,1 / 45	35	8 x 8

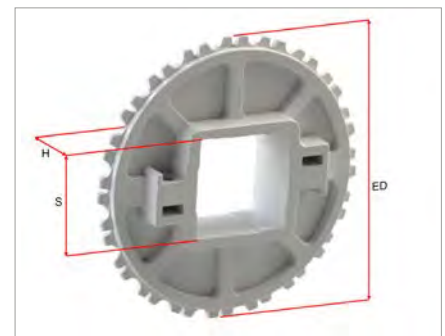
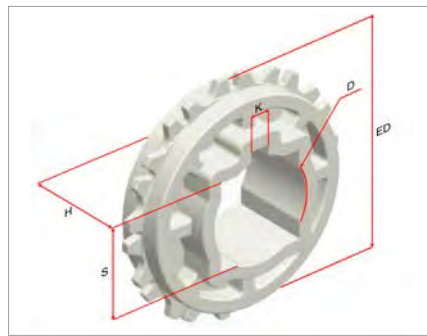
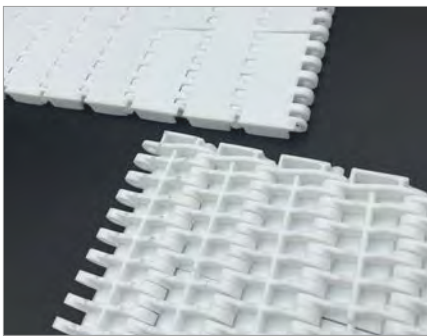

Accessories

Type	Height (mm)	Width (mm)	Molded indent (mm)
Straight flight	25	152,4	-
		101,6	50,8
	50	152,4	-
		101,6	50,8
	75	152,4	-
		101,6	50,8
Pop-up flight	30	152,4	-
Straight flight	4,5	152,4	-
		50,8 / 101,6	6,5
Sidewall	35		
	50		
	80		

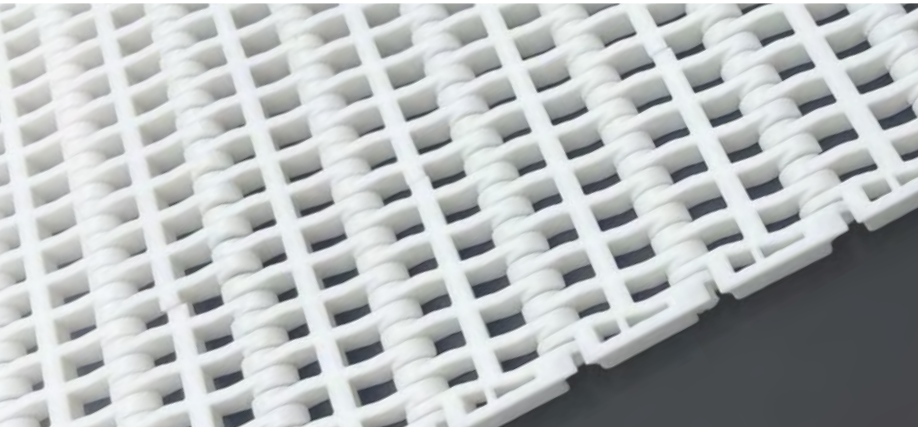

G272-7SBE

Pitch	Open area	FDA & EU	∅ Rod	Flight	Sidewall	Curve
27,2 mm	38 %	✓	4,5 mm	✓	✓	✗

Material	Color	Resistance of the straight belt	Temperature		Belt weight
		Kg/m width	°C (min.)	°C (max.)	Kg/m ²
Polypropylene PP	BL, WH	1040	1	100	4
Polyethylene PE	BL, NT*	520	- 60	60	4,8
Acetal POM	BL*, WH	1620	- 40	80	6,2

Widths

Modules		Minimum belt width (mm)	Width increments (mm)
Central (mm)	Side (mm)		
152,4	50,8 / 101,6	152,4	≈ 8,47

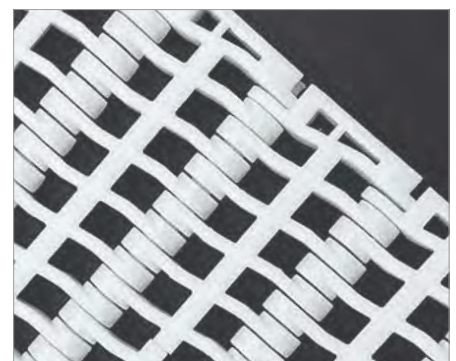
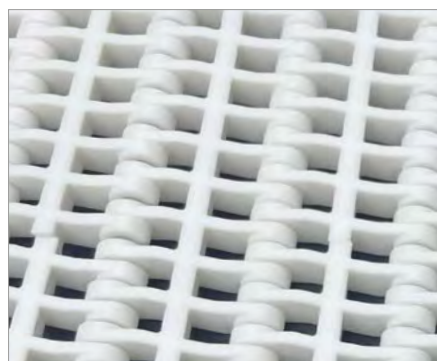
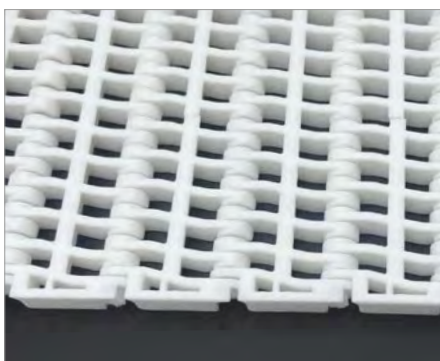

*Consult availability.
BL= Blue, NT= Natural, WH= White.

Sprockets

N° teeth	∅ pitch PD (mm)	∅ external ED (mm)	Square bore S (mm)	Round bore D (mm)	Width H (mm)	Keyway K (mm)
6	54,40	52,3	25,4	-	18,5	-
9	79,53	79,8	25,4 / 38,1 / 40	25,4	21,5	6,35 x 3,17
10	88,02	87,5	25,4 / 38,1 / 40	25,4 / 30	18,8	6,35 x 3,17
12	105,09	105,5	25,4 / 30 / 38,1 / 40	25,4 / 30 / 31,75 / 35 / 38,1 / 45 / 47 / 50	35	6,35 x 3,17
17	148,03	152	-	114	35	4,5 x 4,5
18	156,64	157,8	38,1 / 40 / 50 / 60 / 63,5	25,4 / 30 / 31,75 / 35 / 38,1 / 40 / 46 / 47	35	6,35 x 3,17
20	173,87	175	38,1 / 40 / 60	25,4 / 30 / 31,75 / 38,1	35	6,35 x 3,17
20-Split	173,87	175	60	31,75 / 30	40	6,35 x 3,17
24	208,39	209,8	38,1 / 40	25,4 / 30 / 38,1 / 45	35	8 x 8

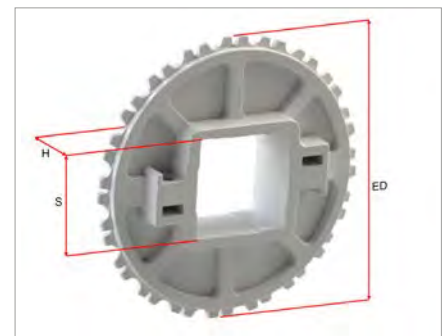
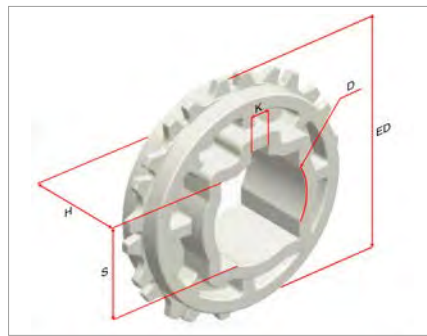
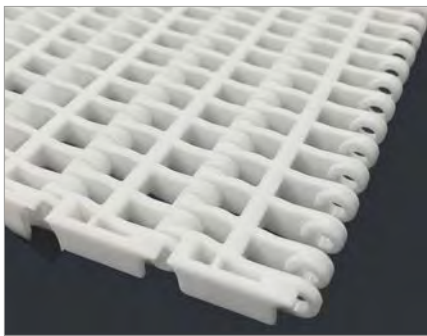

Accessories

Type	Height (mm)	Width (mm)	Molded indent (mm)
Straight flight	25	152,4	-
		101,6	50,8
	50	152,4	-
		101,6	50,8
	75	152,4	-
		101,6	50,8
Pop-up flight	30	152,4	-
Straight flight	4,5	152,4	-
		50,8 / 101,6	6,5
Sidewall	35		
	50		
	80		

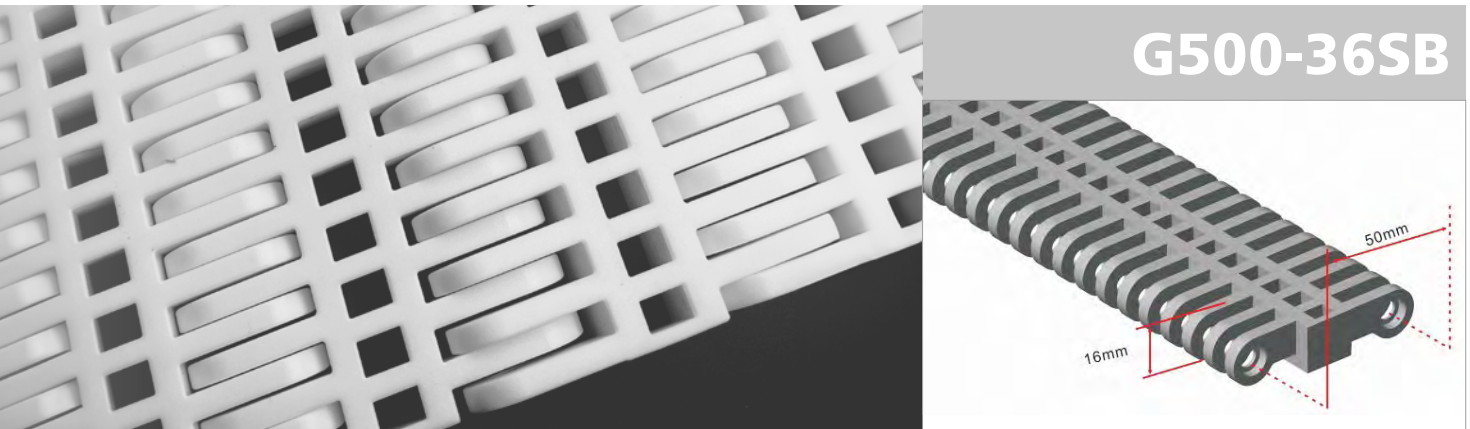

G500-36SB

Pitch	Open area	FDA & EU	∅ Rod	Flight	Sidewall	Curve
50 mm	27 %	✓	5,8 mm	✓	✗	✗

Material	Color	Resistance of the straight belt	Temperature		Belt weight
		Kg/m width	°C (min.)	°C (max.)	Kg/m ²
Polypropylene PP	BL, WH	2795	1	100	8
Polyethylene PE	BL, NT*	1840	- 60	60	8
Acetal POM	BL, WH	4200	- 40	80	12

Widths

Modules (mm)	Minimum belt width (mm)	Width increments (mm)
200	200	10



*Consult availability.
BL= Blue, NT= Natural, WH= White.

Sprockets

N° teeth	∅ pitch PD (mm)	∅ external ED (mm)	Square bore S (mm)	Round bore D (mm)	Width H (mm)	Keyway K (mm)
8	130,66	125,2	40	-	33,8	-
10	161,80	157,0	40	-	33,8	-
12	193,19	189,2	38,1 / 40	30 / 35	33,8	8 x 8

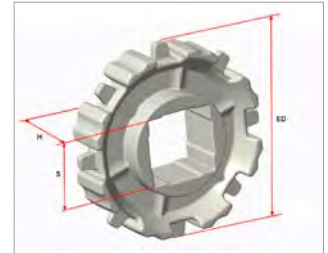

Accessories

Type	Height (mm)	Width (mm)	Molded indent (mm)
Bent flight	75	200	-
	100		
No-cling flight	100	200	-



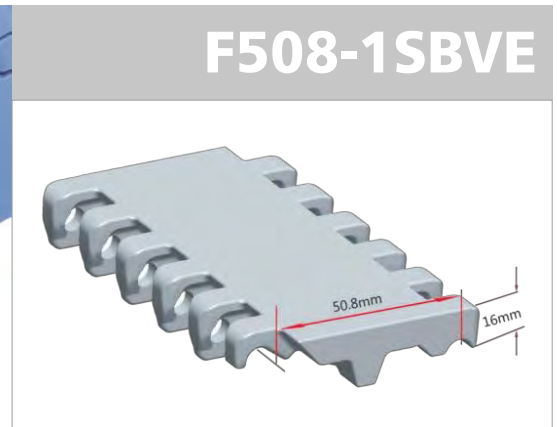
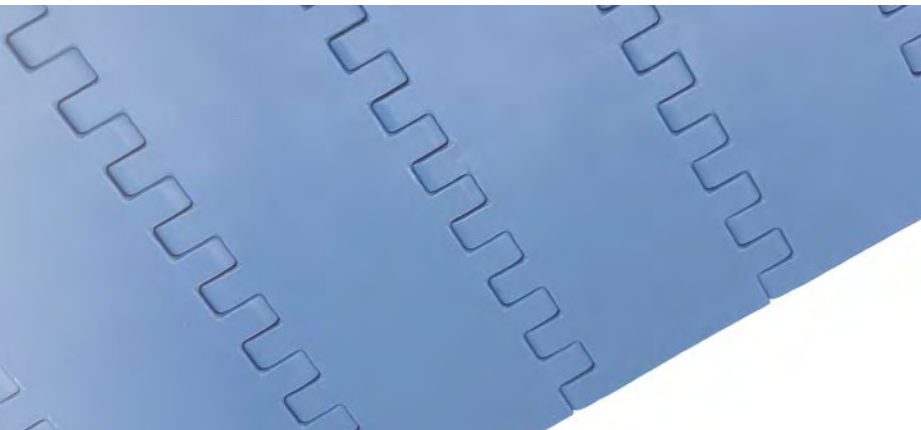

Pitch	Open area	FDA & EU	∅ Rod	Flight	Sidewall	Curve
50,8 mm	0 %	✓	5,8 mm	✓	✓	✗

Material	Color	Resistance of the straight belt	Temperature		Belt weight
		Kg/m width	°C (min.)	°C (max.)	Kg/m ²
Polypropylene PP	BL, WH	1340	1	100	9,3
Polyethylene PE	BL, NT	1280	- 60	60	9,8
Acetal POM	BL, WH	1770	- 40	80	14
Nylon PA	NT	1520	1	180	12,6

Widths

Modules		Minimum belt width (mm)	Width increments (mm)
Central (mm)	Side (mm)		
100,5 / 150,75	100,5 / 150,75	251,25	16,75

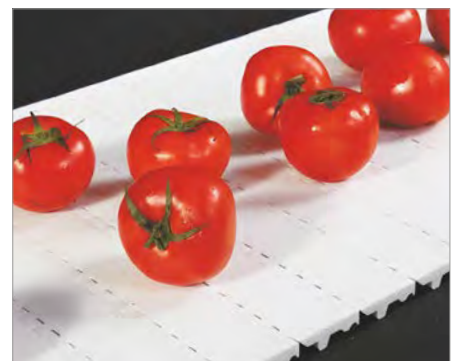
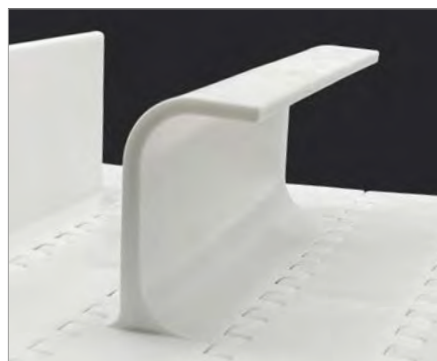
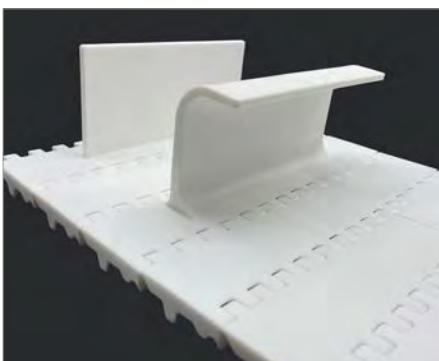

*Consult availability.
BL= Blue, NT= Natural, WH= White.

Sprockets

N° teeth	ø pitch PD (mm)	ø external ED (mm)	Square bore S (mm)	Round bore D (mm)	Width H (mm)	Keyway K (mm)
6 / N	101,60	96,2	25,4 / 38,1 / 40	25,4 / 31,75 / 38,1	37	6,35 x 3,17
8 / N	132,75	123,3	38,1 / 40	25,4 / 25,5 / 30 / 31,75	37	6,35 x 3,17
10 / N	164,39	157,3	38,1 / 40 / 50,8 / 60	25,4 / 30 / 31,75 / 35 / 36 / 38,1 / 50 / 50,8	37	6,35 x 3,17
12 / N	196,28	190,8	38,1 / 40 / 60	-	37	-
16 / N	260,39	253,7	38,1 / 40 / 60 / 63,5	25	37	8 x 8

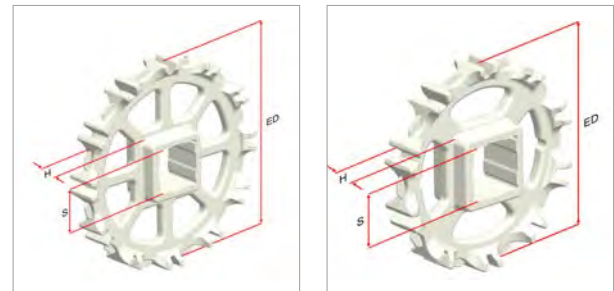

Accessories

Type	Height (mm)	Width (mm)	Molded indent (mm)
Straight flight	25	150,8	-
	50		
	75		
	100		
	150		
Scoop flight	76,2	150,8	-
	101,6		
	152,4		
Pop-up flight	50	150,8	-
Sidewall	60	100,5	38
	85		
	110		
	160		
Molded Sidewall	100	100,5	38
		150,8	38

Installation

■ Sprocket installation

Locate the central sprocket in the exact center of the belt width in order to establish and ensure the belt direction and alignment in a precise way. Fix it by means of two retaining rings.

The rest of the sprockets should not be fitted with retaining rings so that they can absorb the expansion and contraction of the material itself.

The minimum number of sprockets is 3 pcs/shaft.

The distance between sprockets should be less than 145 mm between them.

The distance between sprockets should be less than 90 mm when the length of the conveyor > 4 times the belt width.

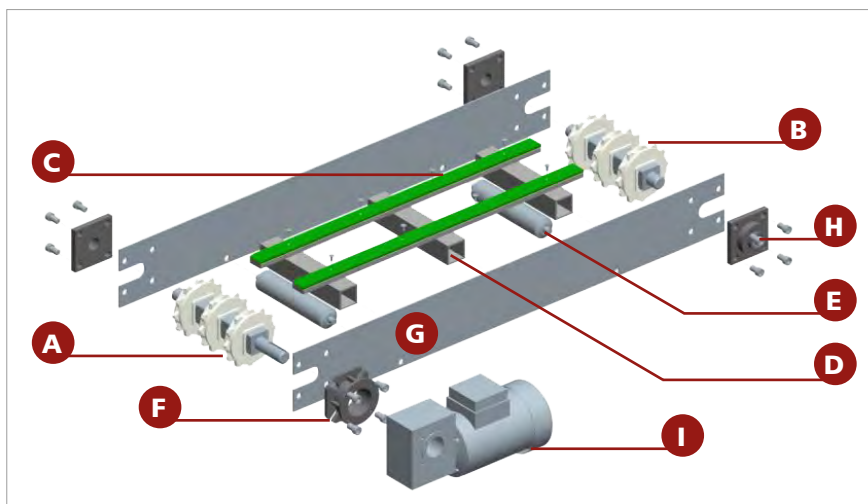
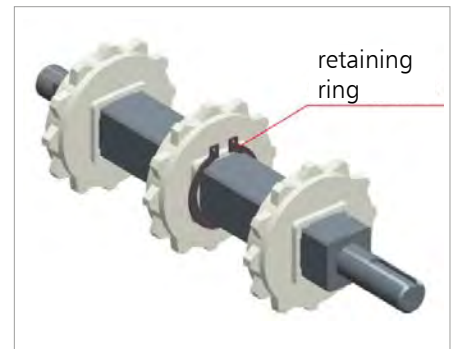

Key	
A	Drive sprocket
B	Sprocket
C	Wear strips
D	Support bar
E	Return supporting roller
F	Motor mounting flange
G	Side plate
H	Bearing
I	Motor speed reducer

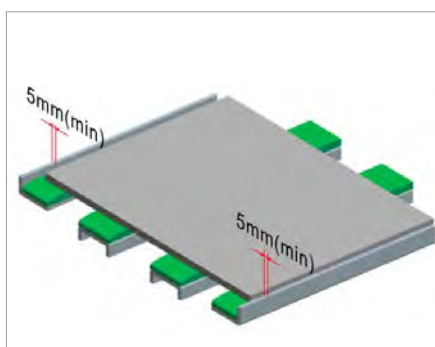

Allow 5 mm between belt width and maximum conveyor width for correct belt tracking.

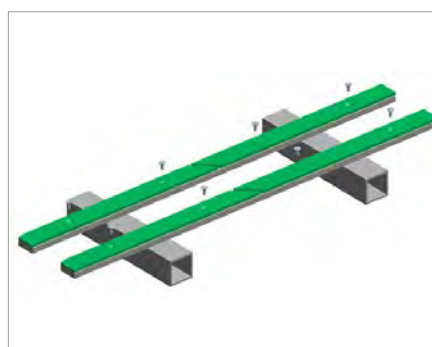

The most common wear strips. They can be welded or fixed to the conveyor frame with bolts (make sure the bolt does not protrude from the strip itself).



Herringbone type wear strips allow:

- Support of the full width of the belt.
- More uniform abrasion of the belt than straight wear strips.
- Better guide effect.

General tolerances

■ Pitch 15,2 mm

Material	Belt width	
	≤ 750 mm	> 750 mm
Polypropylene PP	± 3 mm	± 0,4 %
Polyethylene PE	± 4 mm	± 0,5 %
Acetal POM	± 4 mm	± 0,5 %

■ Pitch 25 / 25,4 / 27,2 mm

Material	Belt width	
	≤ 750 mm	> 750 mm
Polypropylene PP	± 3 mm	± 0,4 %
Polyethylene PE	± 4 mm	± 0,5 %
Acetal POM	± 4 mm	± 0,5 %

■ Pitch 50 / 50,8 mm

Material	Belt width	
	≤ 750 mm	> 750 mm
Polypropylene PP	± 4 mm	± 0,5 %
Polyethylene PE	± 5 mm	± 0,6 %
Acetal POM	± 5 mm	± 0,6 %

esbelt

SWAPbelts

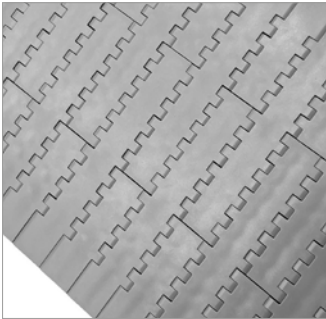

F152-11SBE

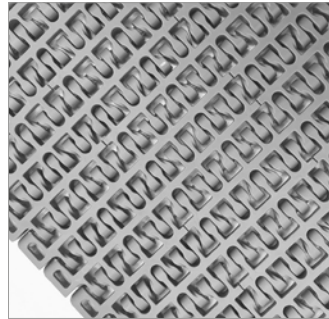

G152-11SBE

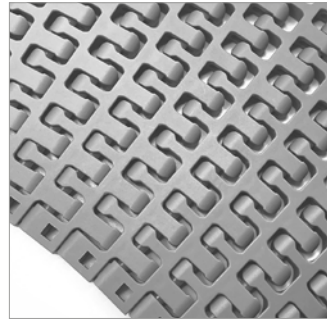

GC250-5SB

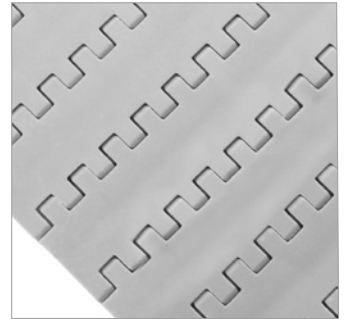

F254-2SBV

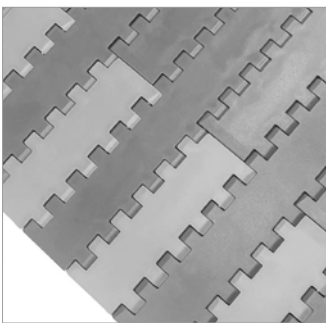

F254-5SB2V

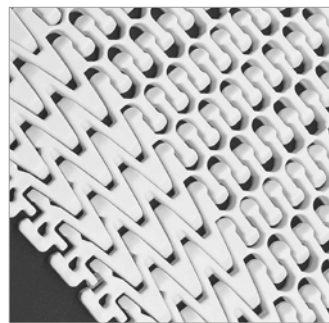

GC254-24SB

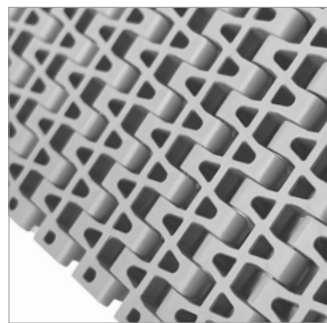

G254-25SB

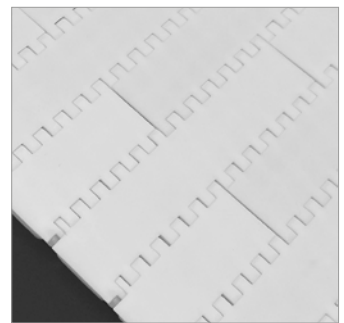

F272-7SBE

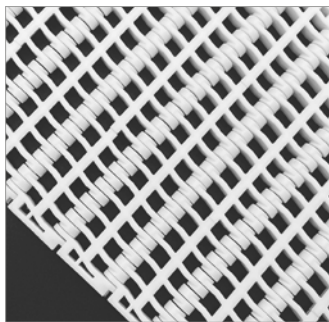

G272-7SBE

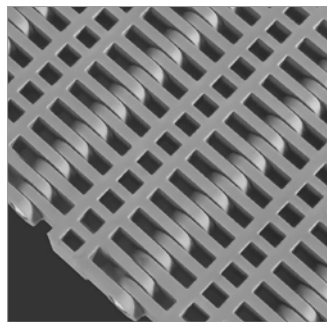

G500-36SB

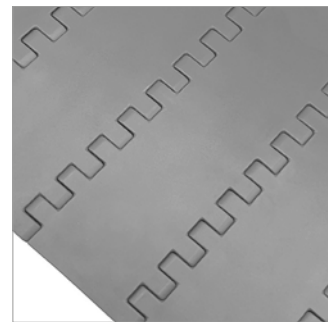

F508-1SBVE



Esbelt Group companies:

Esbelt SAU

Provença, 385
08025 Barcelona
Spain
Tel. +34-93 207 33 11
www.esbelt.com
esbelt@esbelt.com

Esbelt GmbH

Habichtweg 2
41468 Neuss
Germany
Tel. +49-2131 9203-0
www.esbelt.de
info@esbelt.de

Esbelt SAS

190 Av. du Roulage / ZA du Roulage
32600 Pujaudran
France
Tel. +33-5 42 54 54 54
www.esbelt.fr
esbelt@esbelt.fr

Esbelt Corporation

13975 Riverport Place Suite 105
Maryland Heights, MO 63043
USA
Tel. +1-636 294 3200
www.esbelt.us
esbelt@esbelt.us

Esbelt ApS

Agerhatten 16B - Indgang 2
DK-5220 Odense SØ
Denmark
Tel. +45 70 20 62 09
www.esbelt.dk
esbelt@esbelt.dk