

Hairise[®]
chains

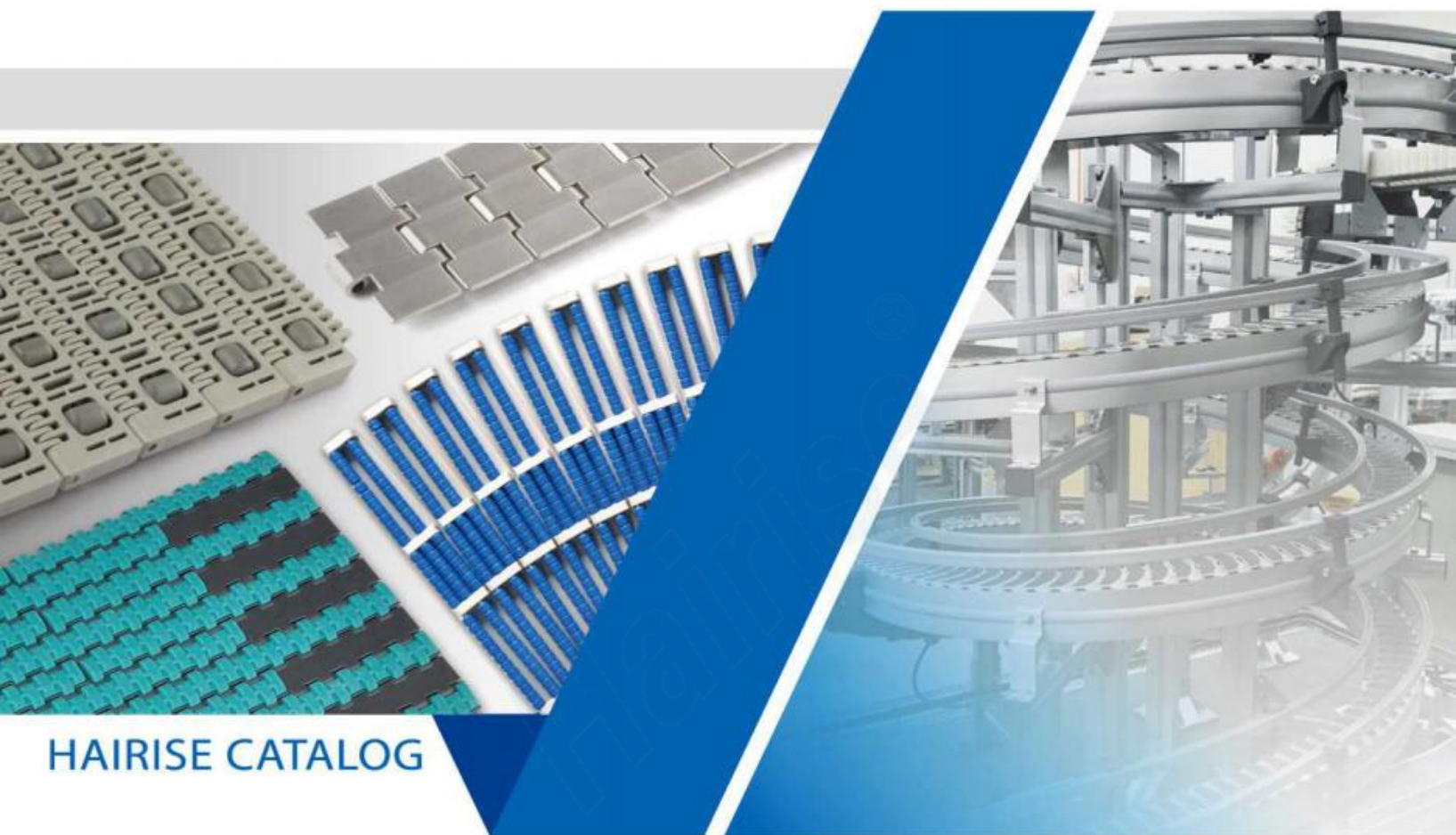

HAIRISE CATALOG

奥佳股份

2020 Version



COMPANY
INTRODUCTOIN

公司简介

PROFESSIONAL ACHIEVEMENT
QUALITY

上海奥佳传动设备股份有限公司
(慕佳自动化科技(上海)有限公司)

是一家集研发、设计、生产、销售为一体的专业从事自动化输送设备及配件等的综合型企业，也是业内第一家挂牌上市的企业。产品涵盖：模具制造、注塑、机加工、整厂设计规划四大板块。公司本着“品质为本，服务至上”的经营理念，经过多年的发展已在业界享有很高的盛誉，同时与国内外知名企业取得了良好的合作，产品广泛应用于食品、饮料、包装制罐、烟草、医药化工、电子电器、轮胎、汽车、物流等行业。

Shanghai All-Ka Transmission Equipment Co.,Ltd(Mu Jia Automation Technology(shanghai)Company Limited) is an intergrated enterprise engaged in the research & development, design, manufacture and sale of automatic conveying equipment,components, etc. We have listed in shanghai. Our production line include: module manufacture, injection molding, machining, factory floor planning. Insisting on the operation principle of "Quality Based and Service First", our company has won a high reputation through many years of development. We also cooperate with some well-known domestic and overseas enterprise. Our products are widely used in food, soft drink, packaging & manufacturing, tobacco, medicine & chemical, electronics, tire, automobiles and logistics industries.



CONTENT

目录

目录检索 Directory search

01-06 链板 / 网链系列 SLAT TOP CHAINS
MODULAR BELT

链板 Slat Top Chains

T01-52 链板系列 SLAT TOP CHAINS
B01-08 不锈钢链系列 STEEL TABLE TOP CHAINS
F01-46 柔性链系列 FLEXIBLE CHAINS

网链 Modular Belt

M01-144 网链系列 MODULAR BELT

配件 Accessories

S01-70 链轮系列 SPROCKETS
R01-42 护栏系列 RAILS
N01-04 风送条系列 NECK GUIDES
W01-14 垫条系列 FRICTION STRIPS
C01-66 配件系列 CONNECTION PARTS
C58-65 梳子板 PLASTIC TRANSITION BOARDS
C66-67 抓瓶头 CANNED TUNA PARTS
G01-09 导轨系列 BOLTS

输送设备 Chain Conveyor





































H01-04 输送机案例 HAIRISE CONVEYOR CASE
H05 柔性链输送机 PLASTIC FLEXIBLE CHAIN CONVEYOR
H06-09 网带输送机 MODULAR BELT CONVEYOR
H10-11 皮带输送机 PVC&PU BELT CONVEYOR
H12 滚筒输送机 ROLLER CONVEYOR
H13 链板输送机 PLASTIC CHAIN CONVEYOR
H14 金属网链输送机 METAL BELT CONVEYOR
H15-19 行业应用 PRODUCT APPLICATION
H20-22 螺旋输送机 SPIRAL CONVEYOR
H23-26 整厂规划 FACTORY PLANNING





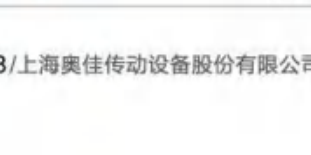







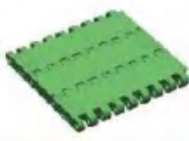







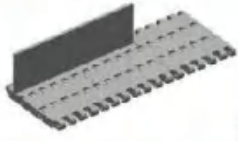













Har-820GHA  T01	Har-820  T02	Har-820FH  T03	Har-820V  T04	Har-820S  T05	Har-828  T06
Har-828T  T07	Har-821  T08	Har-821FHT  T09	Har-821PRR  T10	Har-880  T11	Har-880M  T12
Har-880TAB  T13	Har-880WS  T14	Har-880TABS  T15	Har-880TAB-RT  T16	Har-880STAB  T17	Har-RT114  T18
Har-882  T19	Har-882TAB  T20	Har-882PRR-TAB  T21	Har-882PRR-TAB  T22	Har-882TABF  T23	Har-882  T24
Har-882-PRR  T25	Har-882FH  T26	Har-8P157G  T27	Har-1873/963  T28	Har-843  T29	Har-843  T30
Har-845  T31	Har-963  T32	Har-963TAB  T33	Har-845  T34	Har-1873  T35	Har-1873TAB  T36
Har-1873FHC  T37	Har-1873FA  T38	Har-1873FA  T39	Har-1873-E  T40	Har-1873GJ  T41	Har-1873D  T42
Har-1873GJ  T43	Har-1050  T44	Har-1050TAB  T45	Har-1060  T46	Har-1060FG  T47	Har-NH78  T48
Har-8825  T49	Har-8827  T50	Har-8828  T51			























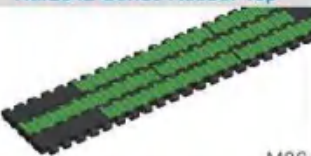











Har-802  B01	Har-812  B02	Har-812FH  B03	Har-981T  B04	Har-981M  B05	Har-981M FH  B06
Har-515  B07	Packing Machine Roller Chain  B08	Har-600  F01	Har-600TAB  F02	Har-1400TAB  F03	Har-1610  F04
Har-1700  F05	Har-1700TAB  F06	Har-1701/1705  F07	Har-042680  F08	Har-216618  F09	Har-216628  F10
Har-1705H  F11	Har-1775  F12	Har-1785  F13	Har-PT250A  F14	Har-PT250B  F15	Har-PT280  F16
Har-2300  F17	Har-2310  F18	Har-2100  F19	Har-2000  F20	Har-2480PMO  F21	Har-2480PMO  F22
Har-2480PMZ  F23	Har-2350PW  F24	Har-2350PW  F25	Har-2350PW  F26	Har-2350PW  F27	Har-2350PW  F28
Har-2350TM  F29	Har-2350PW-VT  F30	Har-2350PW-VTR  F31	Har-2350PW-VTR  F32	Har-2350VTC  F33	Har-2350V  F34
Har-2480GZM  F35	Har-2840  F36	Har-2350  F37	Har-2350  F38	Har-2350DM  F39	Har-2580  F40
Har-2580  F41	Har-830T  F42	Har-1900A  F43	Har-1900B  F44	Har-1900C  F45	Har-1800  F46

不锈钢链 Steel Table Top Chains































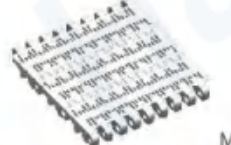
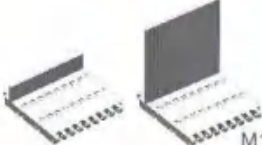



柔性链 Flexible Chains

<p>Har50SG Series Flat Top</p>  <p>M01</p>	<p>Har7900 Series Flat Top</p>  <p>M02</p>	<p>Har7900 Series Nub Top</p>  <p>M03</p>	<p>Har7930 Series Flat Top</p>  <p>M04</p>
<p>Har7930 Series Flush Grid</p>  <p>M05</p>	<p>Har500 Series Flush Grid</p>  <p>M06</p>	<p>Har510 Series Flush Grid</p>  <p>M07</p>	<p>Har1270 Series Flat Top</p>  <p>M08</p>
<p>Har1270 Series Flat Top</p>  <p>M09</p>	<p>Har1270 Series Flush Grid</p>  <p>M10</p>	<p>Har7120 Series Flush Grid</p>  <p>M11</p>	<p>Har7940 Series Flush Grid</p>  <p>M12</p>
<p>Har1500 Series Flat Top</p>  <p>M13</p>	<p>Har2120 Series Flat Top</p>  <p>M14</p>	<p>Har2120 Series Rubber Top</p>  <p>M15</p>	<p>Har2120 Series Flat Top With Positrack</p>  <p>M16</p>
<p>Har2120 Series Flat Top</p>  <p>M17</p>	<p>Har1100 Series Flat Top</p>  <p>M18</p>	<p>Har1100 Series Flush Grid</p>  <p>M19</p>	<p>Har1100 Series Rubber Top</p>  <p>M20</p>
<p>Har1100 Series Flush Grid Dynamic Transition</p>  <p>M21</p>	<p>Har1507 Series Flat Top</p>  <p>M22</p>	<p>Har1100 Series Roller Top</p>  <p>M23</p>	<p>Har1505 Series Flat Top</p>  <p>M24</p>
<p>Har1505 Series Rubber Top</p>  <p>M25</p>	<p>Har1506 Series Flat Top</p>  <p>M26</p>	<p>Har8505 Series Flat Top</p>  <p>M27</p>	<p>Har8505 Series Raised Rib</p>  <p>M28</p>
<p>Har8505 Series Flat Top Dynamic Transition</p>  <p>M29</p>	<p>Har1990 Series Flat Top</p>  <p>M30</p>	<p>Har5935 Series Flush Grid</p>  <p>M31</p>	<p>Har5935 Series Perforated Top</p>  <p>M32</p>
<p>Har5935 Series Flat Top</p>  <p>M33</p>	<p>Har5935 Series Flush Grid Dynamic Transition</p>  <p>M34</p>	<p>Har5935 Series Flat Top</p>  <p>M35</p>	<p>Har100 Series Flush Grid</p>  <p>M36</p>

<p>Har100 Series Raised Rib</p>  <p>M37</p>	<p>Har1000 Series Flat Top</p>  <p>M38</p>	<p>Har1000 Series Flat Top With Positrack</p>  <p>M39</p>	<p>Har1000 Series Flush Grid</p>  <p>M40</p>
<p>Har1000 Series Flush Grid With Positrack</p>  <p>M41</p>	<p>Har1000 Series Flat Top With Positrack</p>  <p>M42</p>	<p>Har1000 Series Rubber Top</p>  <p>M43</p>	<p>Har1000 Series Raised Rib</p>  <p>M44</p>
<p>Har1000 Series Flat Top With Positrack</p>  <p>M45</p>	<p>Har1000 Series Raised Rib</p>  <p>M46</p>	<p>Har1000 Series Raised Rib</p>  <p>M47</p>	<p>Har1001 Series Flat Top</p>  <p>M48</p>
<p>Har1005 Series Flat Top With Positrack</p>  <p>M49</p>	<p>Har1005 Series Roller Top</p>  <p>M50</p>	<p>Har1005 Series Rubber Top</p>  <p>M51</p>	<p>Har1005 Series Flat Top Dynamic Transition With Positioners</p>  <p>M52</p>
<p>Har2400 Series Flush Grid</p>  <p>M53</p>	<p>Har2400 Series Flush Grid With Corner Track</p>  <p>M54</p>	<p>Har2400H Series Raised Rib</p>  <p>M55</p>	<p>Har2401 Series Flush Grid</p>  <p>M56</p>
<p>Har2546 Series Flush Grid</p>  <p>M57</p>	<p>Har2545 Series Flush Grid</p>  <p>M58</p>	<p>Har2520 Series Flat Top</p>  <p>M59</p>	<p>Har2520 Series Flush Grid</p>  <p>M60</p>
<p>Har2520 Series Rubber Top</p>  <p>M61</p>	<p>Har2541 Series Flush Grid</p>  <p>M62</p>	<p>Har2540 Series Flush Grid</p>  <p>M63</p>	<p>Har7100 Series Flush Grid</p>  <p>M64</p>
<p>Har7100A Series Flush Grid</p>  <p>M65</p>	<p>Har7300 Series Flush Grid</p>  <p>M66</p>	<p>Har7705 Series Flat Top</p>  <p>M67</p>	<p>Har7706 Series Roller Top</p>  <p>M68</p>
<p>Har7910A Series Flush Grid</p>  <p>M69</p>	<p>Har7910B Series Flush Grid</p>  <p>M70</p>	<p>HarQNB Series Flat Top</p>  <p>M71</p>	<p>HarQNB Series Rubber Top</p>  <p>M72</p>

HarQNC Series Nub Top  M73	Har1400 Series Flat Top  M74	Har1400 Series Flat Top With Positrack  M75	Har1400 Series Flat Top With Positrack  M76
Har1400 Series Diamond Grid Anti Slip  M77	Har1600 Series Flat Top  M78	Har1600 Series Flush Grid  M79	Har1600 Series Flat Top With Positrack  M80
Har1600T Series Flat Top  M81	Har2501 Series Flat Top  M82	Har2501 Series Nub Top  M83	Har2501 Series Flush Grid  M84
Har2542 Series Flat Top With Positrack  M85	Har2542 Series Rubber Top  M86	Har900 Series Flat Top  M87	Har900 Series Flush Grid  M88
Har900 Series Perforated Flat Top  M89	Har900 Series Rubber Top  M90	Har900 Series Flush Grid With Rubber  M91	Har900 Series Raised Rib  M92
Har900 Series Flush Grid Dynamic Transition  M93	Har900 Series Packaging Machine Separation Chain A  M94	Har900 Series Packaging Machine Separation Chain B  M95	Har900 Series Packaging Machine Separation Chain C  M96
Har900 Series Packaging Machine Separation Chain D  M97	Har900 Series Packaging Machine Separation Chain E  M98	Har900 Series Flat Top With Positrack  M99	Har900 Series Flat Top  M100
Har900 Series Flush Grid  M101	Har900N Series Flush Grid  M102	Har7920 Series Flush Grid  M103	Har7960 Series Flush Grid  M104
Har7960 Series Rubber Top  M105	Har7960 Series Pusher  M106	Har2265 Series Flush Grid With Positrack  M107	Har2275 Series Turning Type With Bearing  M108

网链 Modular Belt

<p>Har2300 Series Flush Grid Turning</p>  <p>M109</p>	<p>Har3811GB Series Flat Top</p>  <p>M110</p>	<p>Har1700T Series</p>  <p>M111</p>	<p>Har1700T Series Nub Top</p>  <p>M112</p>
<p>Har4705 Series Flat Top</p>  <p>M113</p>	<p>Har4705 Series Perforated Top</p>  <p>M114</p>	<p>Har4707 Series Raised Rib</p>  <p>M115</p>	<p>Har5966 Series Flush Grid</p>  <p>M116</p>
<p>Har7800 Series Flush Grid</p>  <p>M117</p>	<p>Har2200 Series Flush Grid</p>  <p>M118</p>	<p>Har7500 Series Flush Grid</p>  <p>M119</p>	<p>Har7501 Series Flush Grid</p>  <p>M120</p>
<p>Har200 Series Flush Grid</p>  <p>M121</p>	<p>Har400 Series Flush Grid</p>  <p>M122</p>	<p>Har400 Series Flush Grid (New Type)</p>  <p>M123</p>	<p>Har400 Series Raised Rib</p>  <p>M124</p>
<p>Har400 Series Lateral Pulley Type</p>  <p>M125</p>	<p>Har400 Series Ball Belt</p>  <p>M126</p>	<p>Har600 Series Fastening</p>  <p>M127</p>	<p>Har800 Series Flat Top</p>  <p>M128</p>
<p>Har800 Series Perforated Flat Top</p>  <p>M129</p>	<p>Har800 Series Flush Grid</p>  <p>M130</p>	<p>Har6100 Series Flat Top</p>  <p>M131</p>	<p>Har6100 Series Flush Grid</p>  <p>M132</p>
<p>Har6100 Series Raised Rib</p>  <p>M133</p>	<p>Har6100 Series Perforated Flat Top</p>  <p>M134</p>	<p>Har7200 Series Flush Grid</p>  <p>M135</p>	<p>Har3110 Series Raised Rib</p>  <p>M136</p>
<p>Har8200 Series Curve</p>  <p>M137</p>	<p>Har7950 Series Flush Grid</p>  <p>M138</p>	<p>Har5997 Series Raised Rib</p>  <p>M139</p>	<p>Har4809 Series Raised Rib</p>  <p>M140</p>
<p>Har7620 Series Flat Top</p>  <p>M141</p>	<p>Har7620 Series Cleat</p>  <p>M142</p>	<p>Har8600 Series Curve</p>  <p>M143</p>	<p>Har1272 Series Flat Top Curve</p>  <p>M144</p>

Har820GHA Series Straight TOP CHAINS

TOP CHAINS 820GHA Series
P=38.1mm, T=14.2mm
PIN:Stainless steel



节距 Pitch	链板材质 Material	颜色 Color
38.1mm	POM	灰色/Gray

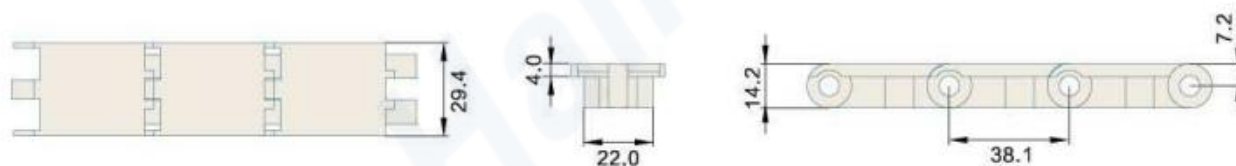

型号 Type No.	宽度 Width (mm)	节距 Pitch (mm)	重量 Weight (Kg/m)	负载 Working Capacity (N)
Har820GHA-K118	29.4	38.1	0.46	1230
Har820GHA-K157	40.0	38.1	0.52	1230

链轮 Sprocket	护栏 Guide	弯轨 Guide Rails	其余配件 Component
—	R01-R42	—	C01-C57

Har820 Series Straight TOP CHAINS

TOP CHAINS 820
P=38.1mm, T=14.2mm
PIN:Stainless steel

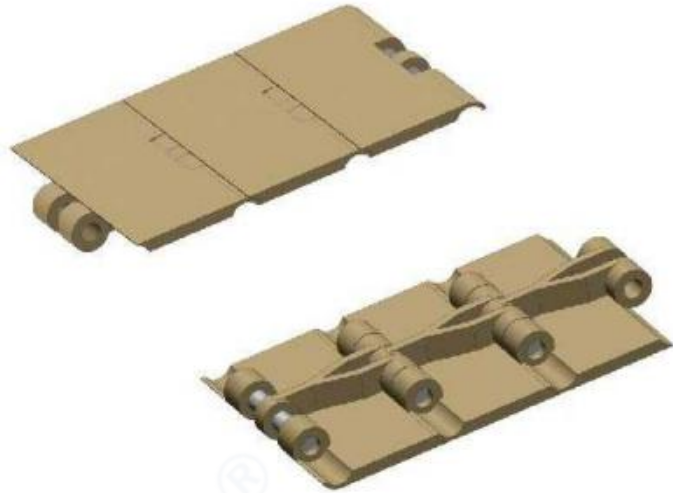

节距 Pitch	链板材质 Material	颜色 Color
38.1mm	POM	咖啡色/Brown

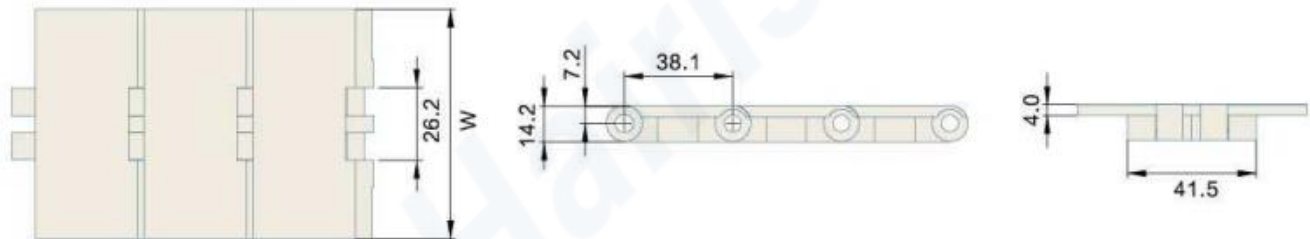

型号 Type No.	宽度 Width (mm)	节距 Pitch (mm)	重量 Weight (Kg/m)	负载 Working Capacity (N)
Har820-K250	63.5	38.1	0.69	1230
Har820-K325	82.6	38.1	0.89	1230
Har820-K350	88.9	38.1	0.91	1230
Har820-K400	101.6	38.1	0.93	1230
Har820-K450	114.3	38.1	1.06	1230
Har820-K600	152.4	38.1	1.30	1230
Har820-K750	190.5	38.1	1.51	1230

链轮 Sprocket	护栏 Guide	弯轨 Guide Rails	其余配件 Component
S12-S13	R01-R42	—	C01-C57

Har820FH Series Rubber Top TOP CHAINS

TOP CHAINS 820FH
P=38.1mm, T=17.3mm

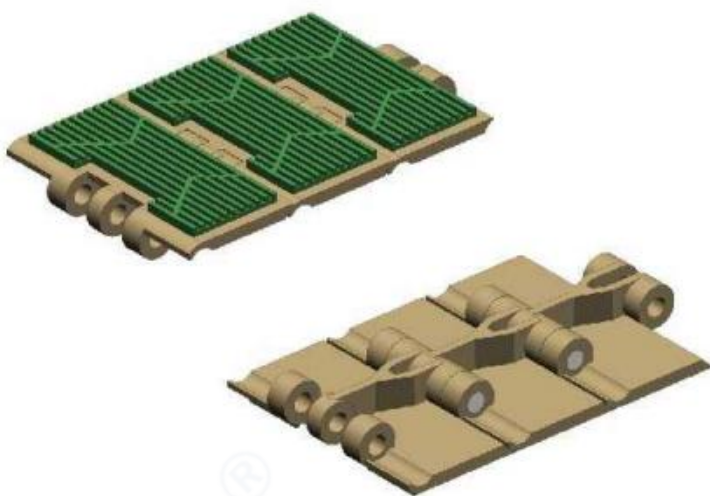

节距 Pitch	链板材质 Material	颜色 Color
38.1mm	PP	咖啡色/Brown

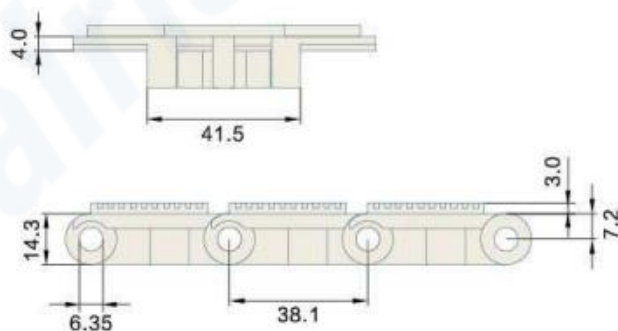
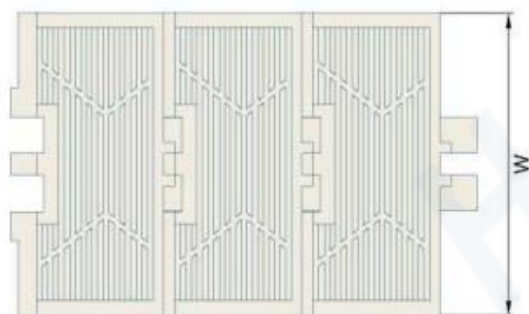

型号 Type No.	宽度 Width (mm)	节距 Pitch (mm)	重量 Weight (Kg/m)	负载 Working Capacity (N)
Har820FH-K325	82.6	38.1	0.85	1030
Har820FH-K750	190.5	38.1	1.45	1030

链轮 Sprocket	护栏 Guide	弯轨 Guide Rails	其余配件 Component
S12-S13	R01-R42	—	C01-C57

Har820V Series Straight TOP CHAINS

TOP CHAINS 820V
P=38.1mm, T=30.7mm
PIN:Stainless steel

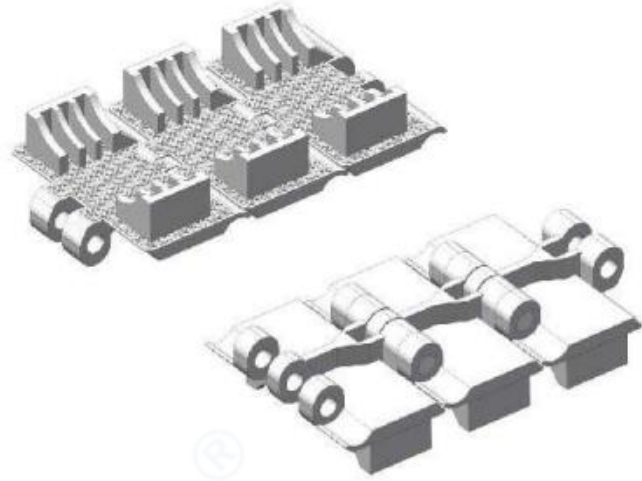

节距 Pitch	链板材质 Material	颜色 Color
38.1mm	POM	白色/White

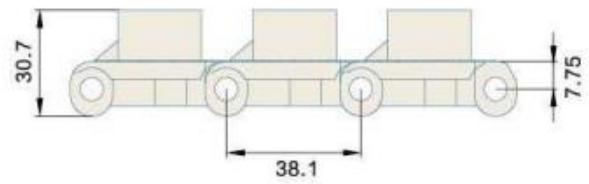
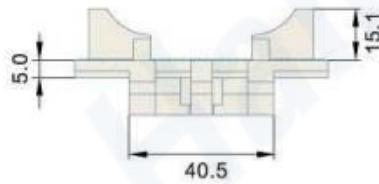
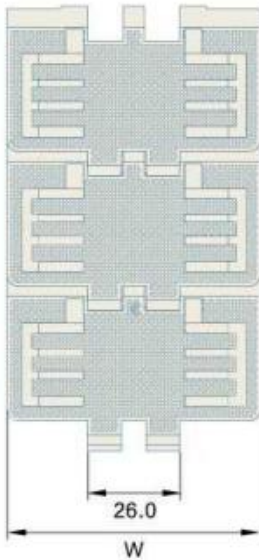

型号 Type No.	宽度 Width (mm)	节距 Pitch (mm)	重量 Weight (Kg/m)	负载 Working Capacity (N)
Har820V-K325	82.6	38.1	1.31	1230

链轮 Sprocket	护栏 Guide	弯轨 Guide Rails	其余配件 Component
S12-S13	R01-R42	—	C01-C57

Har820S Series Straight Anti-Static TOP CHAINS

TOP CHAINS 820S
P=38.1mm, T=14.2mm
PIN:Stainless steel



节距 Pitch	链板材质 Material	颜色 Color
38.1mm	POM	黑色/Black

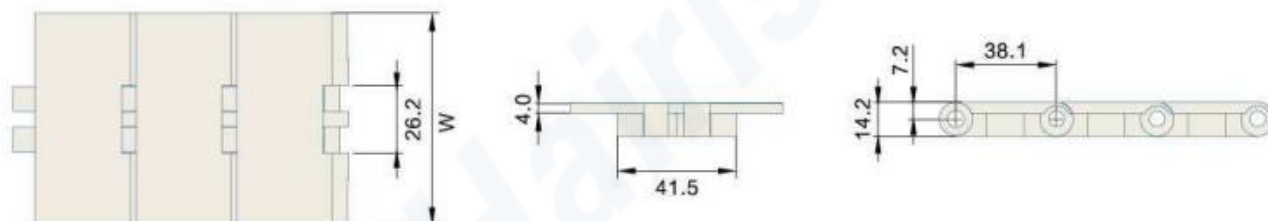

型号 Type No.	宽度 Width (mm)	节距 Pitch (mm)	重量 Weight (Kg/m)	负载 Working Capacity (N)
Har820S-K250	63.5	38.1	0.69	1230
Har820S-k325	82.6	38.1	0.89	1230
Har820S-K350	88.9	38.1	0.91	1230
Har820S-K400	101.6	38.1	0.93	1230
Har820S-K450	114.3	38.1	1.06	1230
Har820S-K600	152.4	38.1	1.30	1230
Har820S-K750	190.5	38.1	1.51	1230

链轮 Sprocket	护栏 Guide	弯轨 Guide Rails	其余配件 Component
S12-S13	R01-R42	—	C01-C57

Har828 Series Straight TOP CHAINS

TOP CHAINS 828
P=38.1mm, T=15.1mm
PIN:Stainless steel



节距 Pitch	链板材质 Material	颜色 Color
38.1mm	POM	咖啡色/Brown

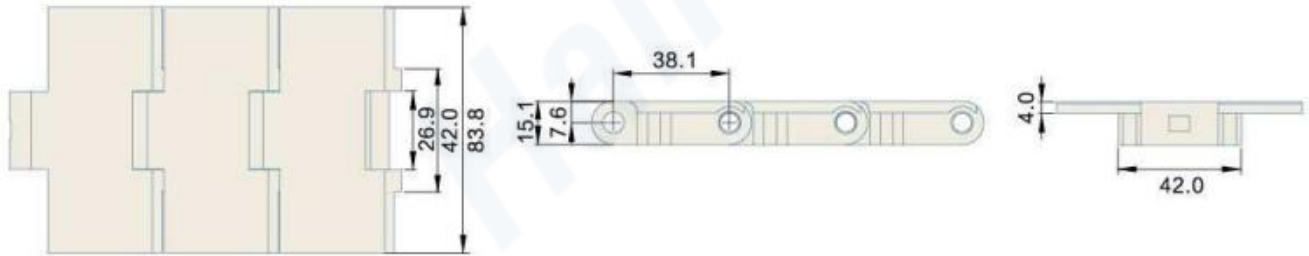

型号 Type No.	宽度 Width (mm)	节距 Pitch (mm)	重量 Weight (Kg/m)	负载 Working Capacity (N)
Har828-K330	83.8	38.1	1.08	2000

链轮 Sprocket	护栏 Guide	弯轨 Guide Rails	其余配件 Component
S17-S18	R01-R42	—	C01-C57

Har828T Series Curve

TOP CHAINS

TOP CHAINS 828T
 P=38.1mm, T=15.1mm
 PIN:Stainless steel

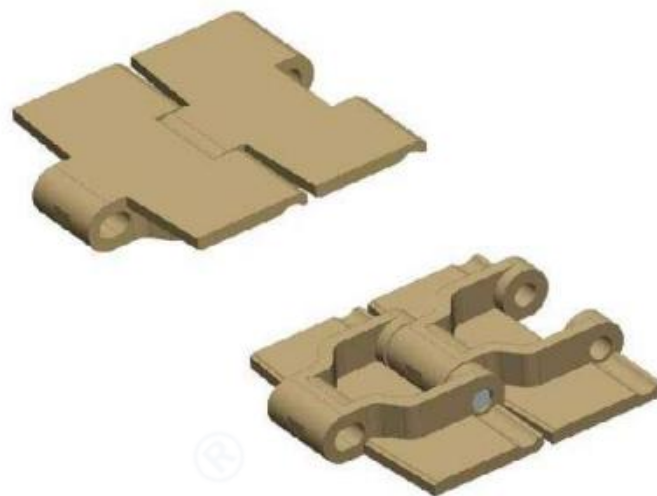

节距 Pitch	链板材质 Material	颜色 Color
38.1mm	POM	咖啡色/Brown

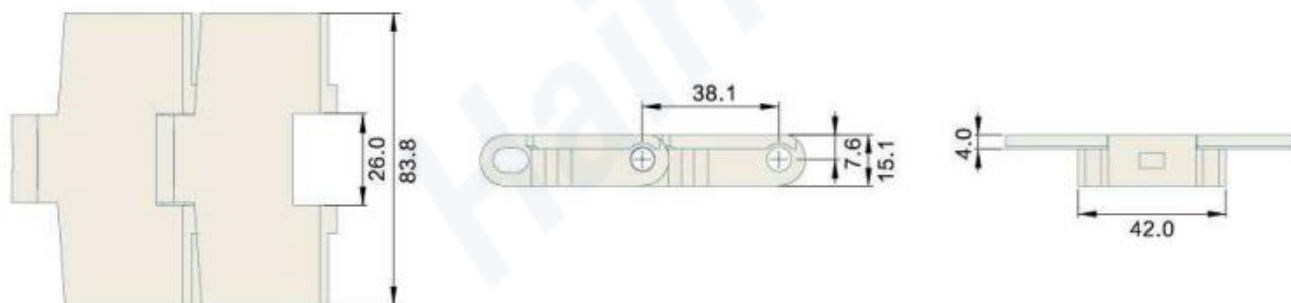

型号 Type No.	宽度 Width (mm)	节距 Pitch (mm)	重量 Weight (Kg/m)	转弯半径 Radius (mm)	负载 Working Capacity (N)
Har828T-K330	83.8	38.1	0.99	510	2000

链轮 Sprocket	护栏 Guide	弯轨 Guide Rails	其余配件 Component
S17-S18	R01-R42	—	C01-C57

Har821 Series Straight TOP CHAINS

TOP CHAINS 821 Series
P=38.1mm, T=14.3mm
PIN:Stainless steel

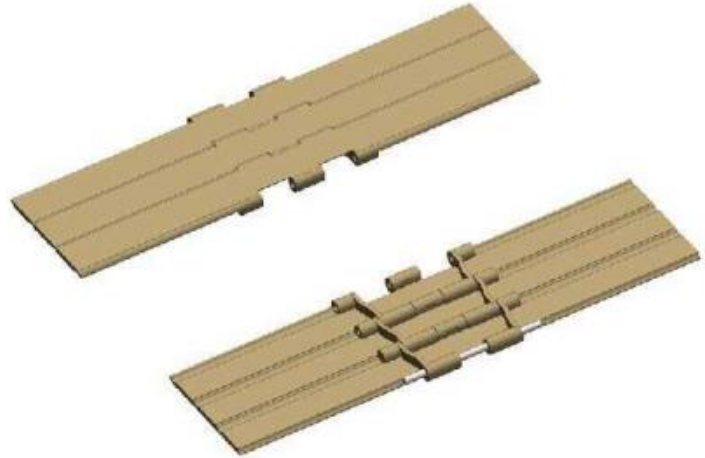

节距 Pitch	链板材质 Material	颜色 Color
38.1mm	POM	咖啡色/Brown

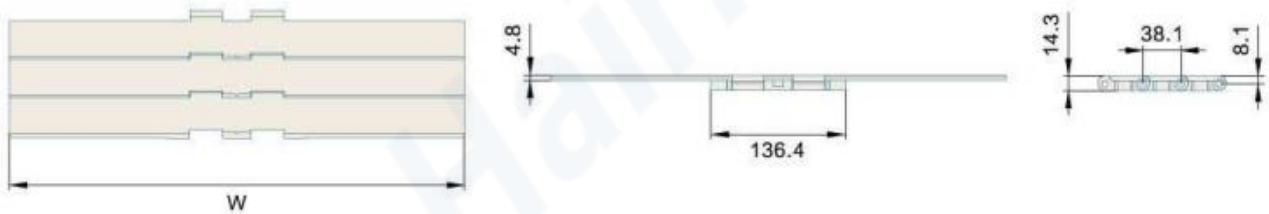

型号 Type No.	宽度 Width (mm)	节距 Pitch (mm)	重量 Weight (Kg/m)	负载 Working Capacity (N)
Har821-K750	190.5	38.1	2.48	2680
Har821-K1000	254.0	38.1	2.82	2680
Har821-K1200	304.8	38.1	3.12	2680
Har821-K1800	457.2	38.1	3.98	2680

链轮 Sprocket	护栏 Guide	弯轨 Guide Rails	其余配件 Component
S14-S16	R01-R42	—	C01-C57

Har821FHT Series Straight TOP CHAINS

TOP CHAINS 821FHT
P=38.1mm, T=16.3mm
PIN:Stainless steel

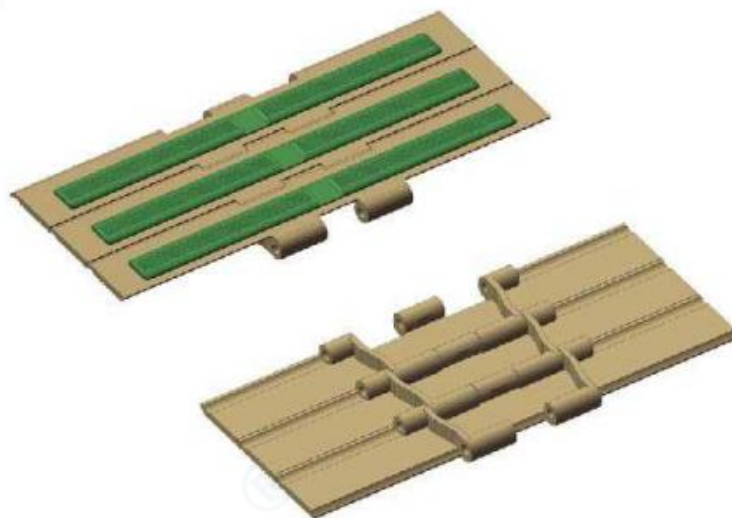

节距 Pitch	链板材质 Material	颜色 Color
38.1mm	POM	咖啡色/Brown

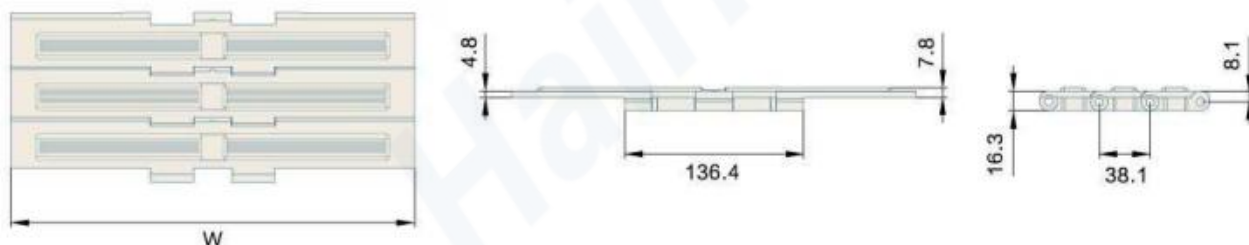

型号 Type No.	宽度 Width (mm)	节距 Pitch (mm)	重量 Weight (Kg/m)	负载 Working Capacity (N)
Har821FHT-K750	190.5	38.1	2.48	2680
Har821FHT-K1000	254.0	38.1	2.92	2680
Har821FHT-K1200	304.8	38.1	3.23	2680

链轮 Sprocket	护栏 Guide	弯轨 Guide Rails	其余配件 Component
S14-S16	R01-R42	—	C01-C57

Har821PRR Series Rubber Top TOP CHAINS

TOP CHAINS 821PRR
P=38.1mm, T=28.8mm



节距 Pitch	链板材质 Material	颜色 Color
38.1mm	POM	咖啡色/Brown

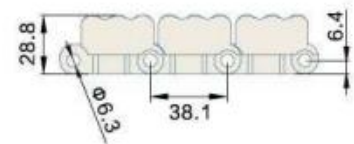
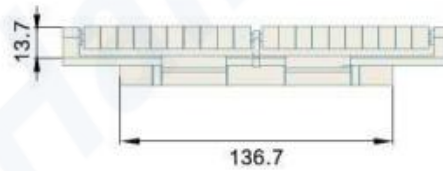
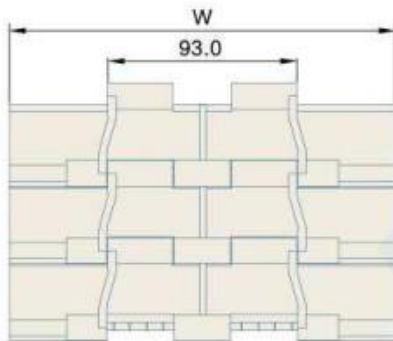

型号 Type No.	宽度 Width (mm)	节距 Pitch (mm)	重量 Weight (Kg/m)	负载 Working Capacity (N)
Har821PRR-K750	190.5	38.1	5.4	2680
Har821PRR-K1000	254.0	38.1	6.7	2680
Har821PRR-K1200	304.8	38.1	7.95	2680

链轮 Sprocket	护栏 Guide	弯轨 Guide Rails	其余配件 Component
S14-S16	R01-R42	—	C01-C57

Har880 Series Curve

TOP CHAINS

TOP CHAINS 880
 P=38.1mm, T=20mm
 PIN:Stainless steel



节距 Pitch	链板材质 Material	颜色 Color
38.1mm	POM	咖啡色/Brown



型号 Type No.	宽度 Width (mm)	节距 Pitch (mm)	重量 Weight (Kg/m)	转弯半径 Radius (mm)	负载 Working Capacity (N)
Har880-K325	82.6	38.1	0.9	510	2000
Har880-K450	114.3	38.1	1.2	510	2000

链轮 Sprocket	护栏 Guide	弯轨 Guide Rails	其余配件 Component
S17-S18	R01-R42	G03-G04	C01-C57

Har880M Series Curve TOP CHAINS

TOP CHAINS 880M
P=38.1mm, T=14.8mm
PIN:Stainless steel



节距 Pitch	链板材质 Material	颜色 Color
38.1mm	POM	咖啡色/Brown

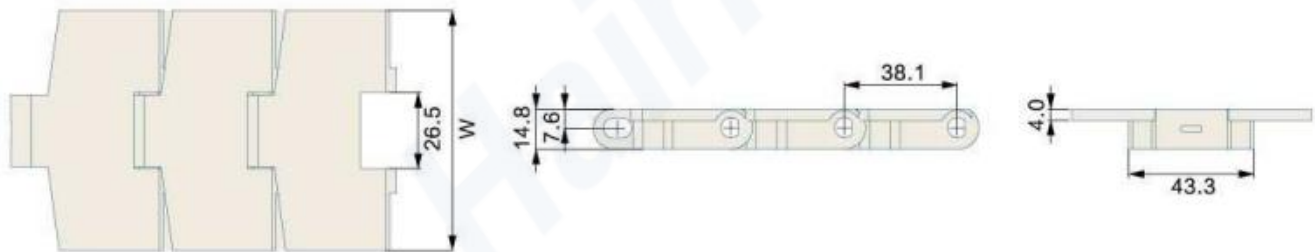

型号 Type No.	宽度 Width (mm)	节距 Pitch (mm)	重量 Weight (Kg/m)	转弯半径 Radius (mm)	负载 Working Capacity (N)
Har880M-K325	82.6	38.1	0.98	510	2000
Har880M-K450	114.3	38.1	1.12	510	2000

链轮 Sprocket	护栏 Guide	弯轨 Guide Rails	其余配件 Component
S17-S18	R01-R42	G03	C01-C57

Har880TAB Series Curve

TOP CHAINS

TOP CHAINS 880TAB
 P=38.1mm, T=19.9mm
 PIN:Stainless steel



节距 Pitch	链板材质 Material	颜色 Color
38.1mm	POM	咖啡色/Brown

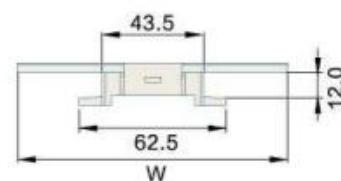
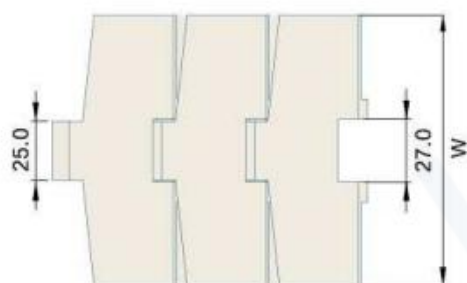

型号 Type No.	宽度 Width (mm)	节距 Pitch (mm)	重量 Weight (Kg/m)	转弯半径 Radius (mm)	负载 Working Capacity (N)
Har880TAB-K325	82.6	38.1	1.05	510	2000
Har880TAB-K450	114.3	38.1	1.24	510	2000

链轮 Sprocket	护栏 Guide	弯轨 Guide Rails	其余配件 Component
S17-S18	R01-R42	G01-G02	C01-C57

Har880WS Series Roller Cleat Curve

TOP CHAINS

TOP CHAINS 880WS

P=38.1mm, T=21.8mm

PIN:Stainless steel

Cleat style(5 types):

Rubber Top cleat /Straight cleat/Oblique cleat/

Roller Cleat/Rubber cleat

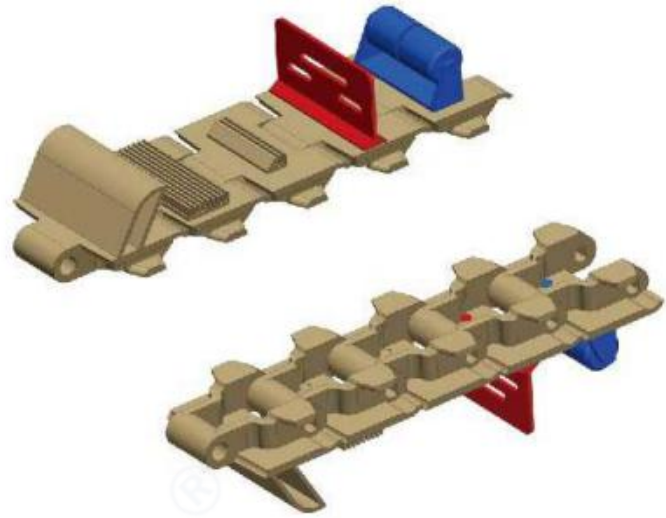

节距 Pitch	链板材质 Material	颜色 Color
38.1mm	POM	咖啡色/Brown

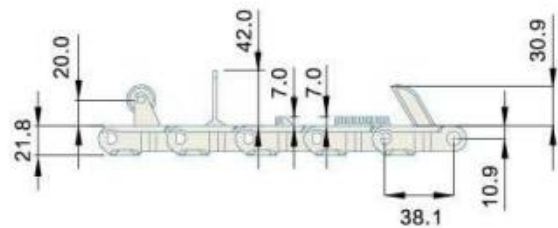
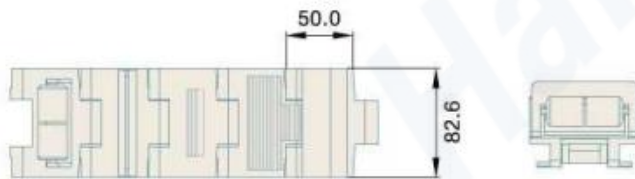

型号 Type No.	宽度 Width (mm)	节距 Pitch (mm)	重量 Weight (Kg/m)	转弯半径 Radius (mm)	负载 Working Capacity (N)
Har880WS-K325	82.6	38.1	1.68	510	2130

链轮 Sprocket	护栏 Guide	弯轨 Guide Rails	其余配件 Component
S17-S18	R01-R42	G01-G02	C01-C57

Har880TABS Series Curve Anti-static

TOP CHAINS

TOP CHAINS 880TABS

P=38.1mm, T=19.9mm

PIN:Stainless steel



节距 Pitch	链板材质 Material	颜色 Color
38.1mm	POM	黑色/Black

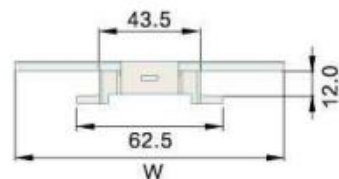
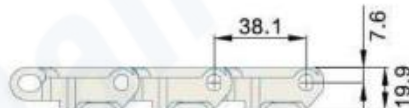
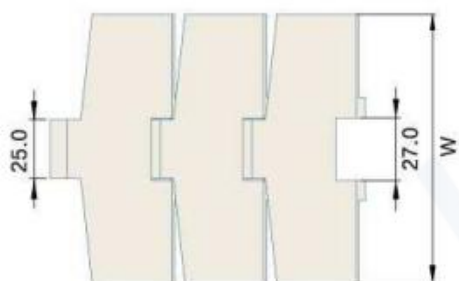

型号 Type No.	宽度 Width (mm)	节距 Pitch (mm)	重量 Weight (Kg/m)	负载 Working Capacity (N)
Har880TABS-K325	82.6	38.1	1.05	2000
Har880TABS-K450	114.3	38.1	1.24	2000

链轮 Sprocket	护栏 Guide	弯轨 Guide Rails	其余配件 Component
S17-S18	R01-R42	G01-G02	C01-C57

Har880TAB-RT Series Curve TOP CHAINS

TOP CHAINS 880TAB-RT Series
P=38.1mm, T=20mm
PIN:Stainless steel



节距 Pitch	链板材质 Material	颜色 Color
38.1mm	POM	咖啡色/Brown

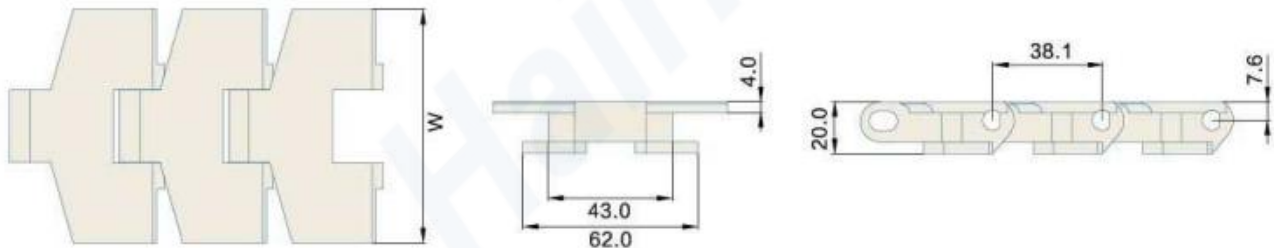

型号 Type No.	宽度 Width (mm)	节距 Pitch (mm)	重量 Weight (Kg/m)	转弯半径 Radius (mm)	负载 Working Capacity (N)
Har880TAB-RT-K325	82.6	38.1	0.96	300	2130
Har880TAB-RT-K450	114.3	38.1	1.10	300	2130

链轮 Sprocket	护栏 Guide	弯轨 Guide Rails	其余配件 Component
S17-S18	R01-R42	G01-G02	C01-C57

Har880STAB Series Curve

TOP CHAINS

TOP CHAINS 880STAB Series
 P=19.05mm, T=17mm
 PIN:Stainless steel

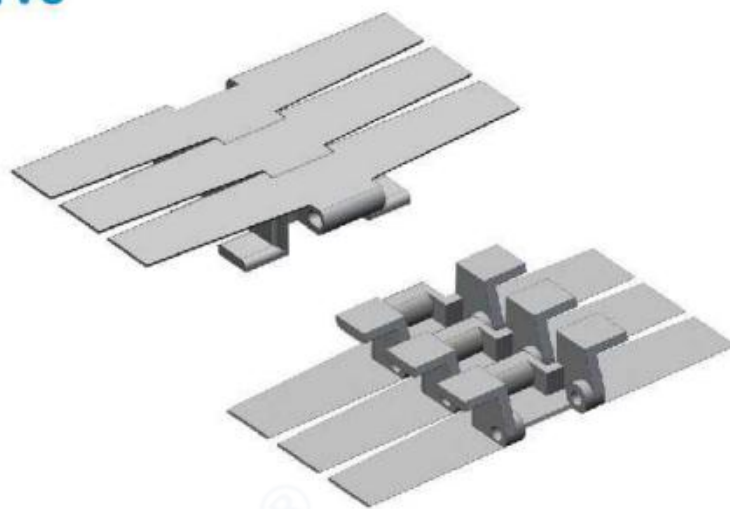

节距 Pitch	链板材质 Material	颜色 Color
19.05mm	POM	白色/White

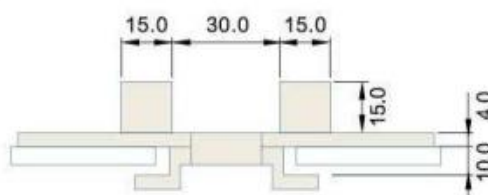
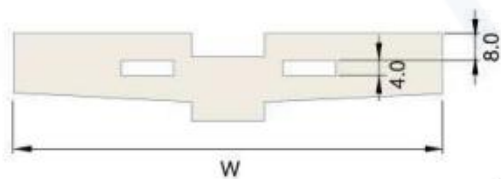
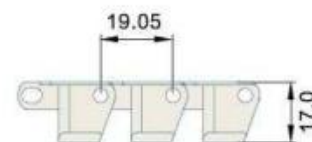
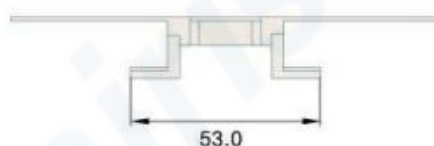
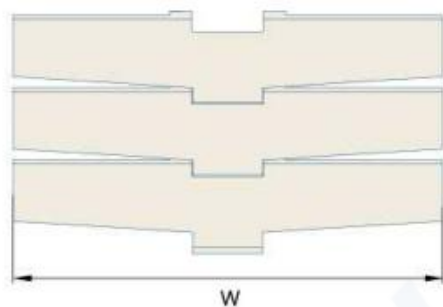

880STABF

型号 Type No.	宽度 Width (mm)	节距 Pitch (mm)	重量 Weight (Kg/m)	转弯半径 Radius (mm)	负载 Working Capacity (N)
Har880STAB-K470	120	19.05	0.78	510	1900
Har880STABF-K470	120	19.05	1.01	510	1900

链轮 Sprocket	护栏 Guide	弯轨 Guide Rails	其余配件 Component
—	R01-R42	—	C01-C57

HarRT114 Series Curve TOP CHAINS

TOP CHAINS RT114
P=38.1mm, T=20mm
PIN:Stainless steel

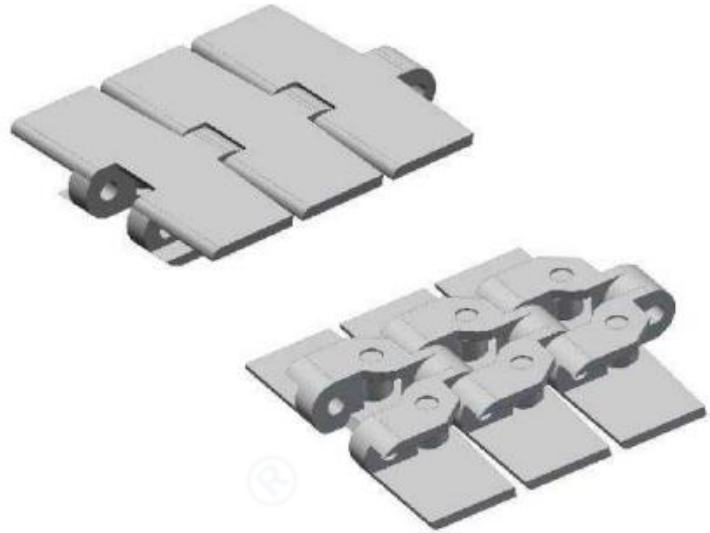

节距 Pitch	链板材质 Material	颜色 Color
38.1mm	POM	白色/White

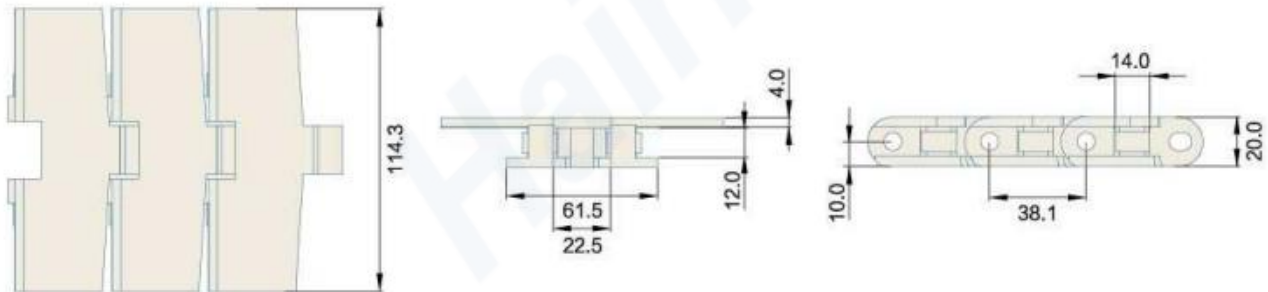

型号 Type No.	宽度 Width (mm)	节距 Pitch (mm)	重量 Weight (Kg/m)	转弯半径 Radius (mm)	负载 Working Capacity (N)
HarRT114	114.3	38.1	1.4	510	2000

链轮 Sprocket	护栏 Guide	弯轨 Guide Rails	其余配件 Component
S69	R01-R42	—	C01-C57

Har882M Series Curve

TOP CHAINS

TOP CHAINS 882
 P=38.1mm, T=19mm
 PIN:Stainless steel

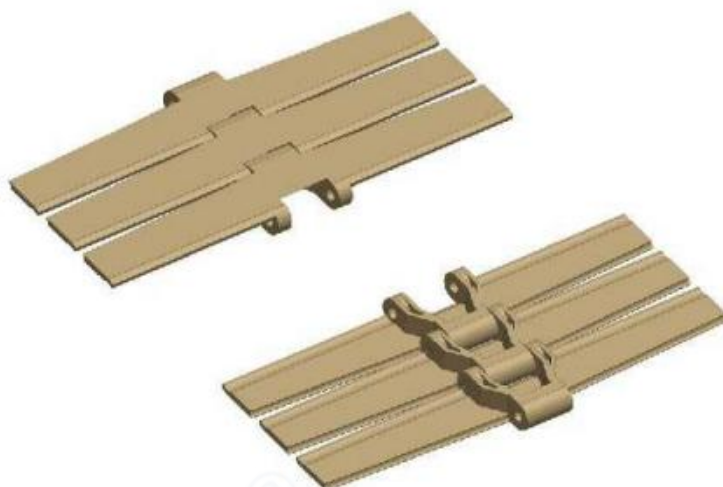

节距 Pitch	链板材质 Material	颜色 Color
38.1mm	POM	咖啡色/Brown

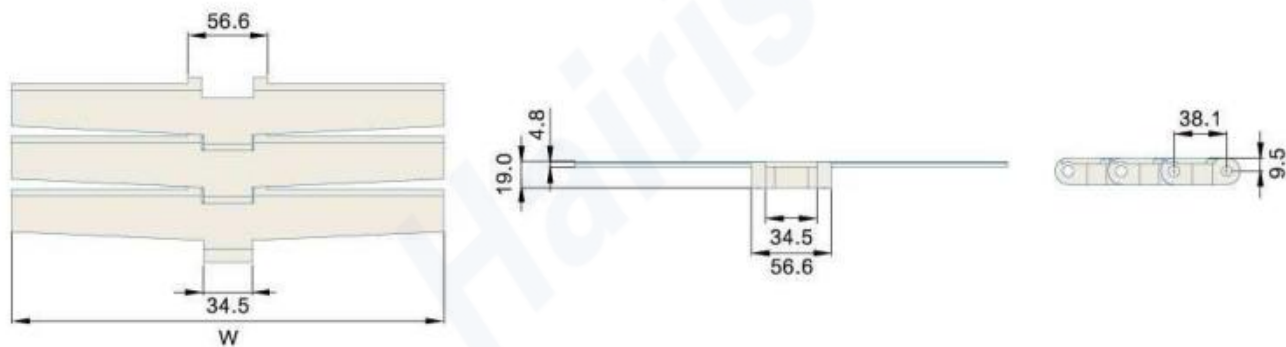

型号 Type No.	宽度 Width (mm)	节距 Pitch (mm)	重量 Weight (Kg/m)	转弯半径 Radius (mm)	负载 Working Capacity (N)
Har882M-K450	114.3	38.1	1.19	610	3830
Har882M-K600	152.4	38.1	1.78	610	3830
Har882M-K750	190.5	38.1	2.16	610	3830
Har882M-K1000	254.0	38.1	2.35	610	3830
Har882M-K1200	304.8	38.1	2.65	610	3830

链轮 Sprocket	护栏 Guide	弯轨 Guide Rails	其余配件 Component
S19-S20	R01-R42	—	C01-C57

Har882TAB Series Curve TOP CHAINS

TOP CHAINS 882TAB
P=38.1mm, T=27mm
PIN:Stainless steel



节距 Pitch	链板材质 Material	颜色 Color
38.1mm	POM	咖啡色/Brown

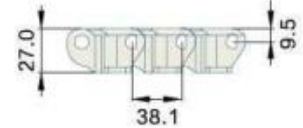
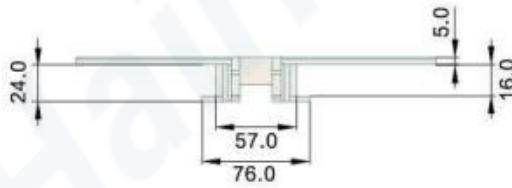
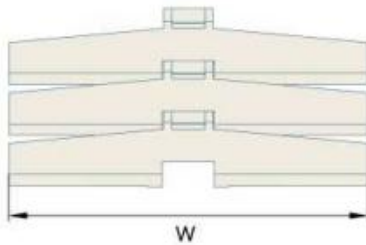

型号 Type No.	宽度 Width (mm)	节距 Pitch (mm)	重量 Weight (Kg/m)	转弯半径 Radius (mm)	负载 Working Capacity (N)
Har882TAB-K375	95.2	38.1	1.40	510	3830
Har882TAB-K600	152.4	38.1	2.18	610	3830
Har882TAB-K750	190.5	38.1	2.34	610	3830
Har882TAB-K1000	254.0	38.1	2.75	610	3830
Har882TAB-K1200	304.8	38.1	3.20	610	3830

链轮 Sprocket	护栏 Guide	弯轨 Guide Rails	其余配件 Component
S19-S20	R01-R42	G04-G06	C01-C57

Har882PRR-TAB Series Curve

TOP CHAINS

TOP CHAINS 882PRR-TAB

P=38.1mm, T=22.6mm

PIN:Stainless steel

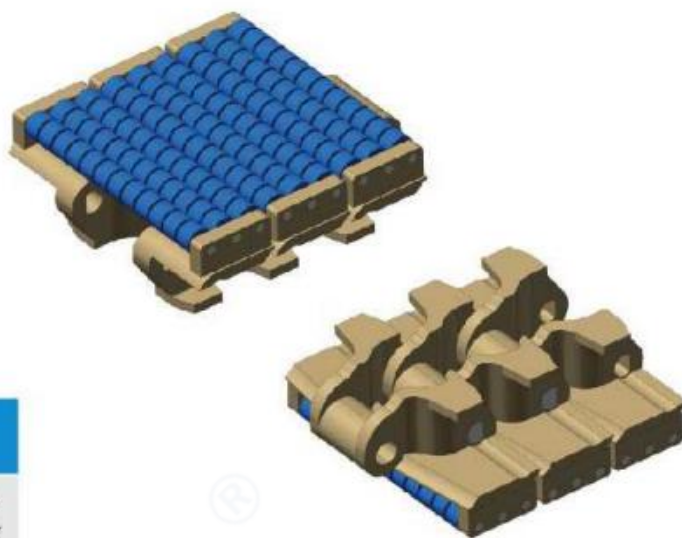

节距 Pitch	链板材质 Material	颜色 Color
38.1mm	POM	棕底蓝珠/Brown Plate Blue Roller 深灰底紫珠/Dark Grey Plate and Purple Roller

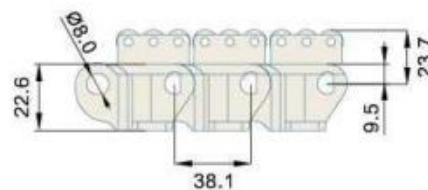
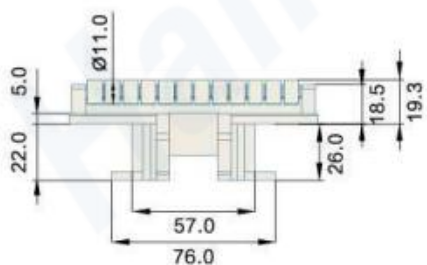

型号 Type No.	宽度 Width (mm)	节距 Pitch (mm)	重量 Weight (Kg/m)	转弯半径 Radius (mm)	负载 Working Capacity (N)
Har882PRR-TAB-K450	114.3	38.1	2.7	510	3820

链轮 Sprocket	护栏 Guide	弯轨 Guide Rails	其余配件 Component
S19-S20	R01-R42	G04-G06	C01-C57

Har882PRR-TAB Series Curve

TOP CHAINS

TOP CHAINS 882PRR-TAB
 P=38.1mm, T=22.6mm
 PIN:Stainless steel



节距 Pitch	链板材质 Material	颜色 Color
38.1mm	POM	棕底蓝珠/ Brown Plate Blue Roller

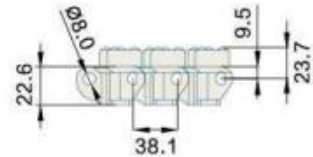
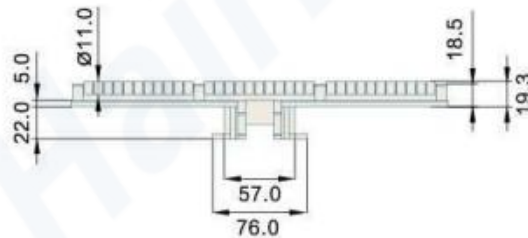
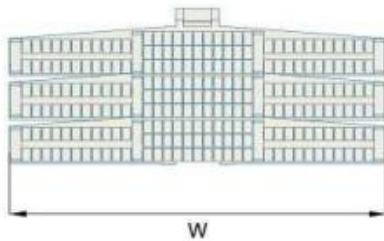

型号 Type No.	宽度 Width (mm)	节距 Pitch (mm)	重量 Weight (Kg/m)	转弯半径 Radius (mm)	负载 Working Capacity (N)
Har882PRR-TAB-K750	190.5	38.1	4.50	610	3820
Har882PRR-TAB-K1000	254.0	38.1	5.85	610	3820
Har882PRR-TAB-K1200	304.8	38.1	6.32	610	3820

链轮 Sprocket	护栏 Guide	弯轨 Guide Rails	其余配件 Component
S19-S20	R01-R42	G04-G06	C01-C57

Har882TABF Series

TOP CHAINS

TOP CHAINS 882TABF

P=38.1mm, T=27mm

PIN: Stainless Steel

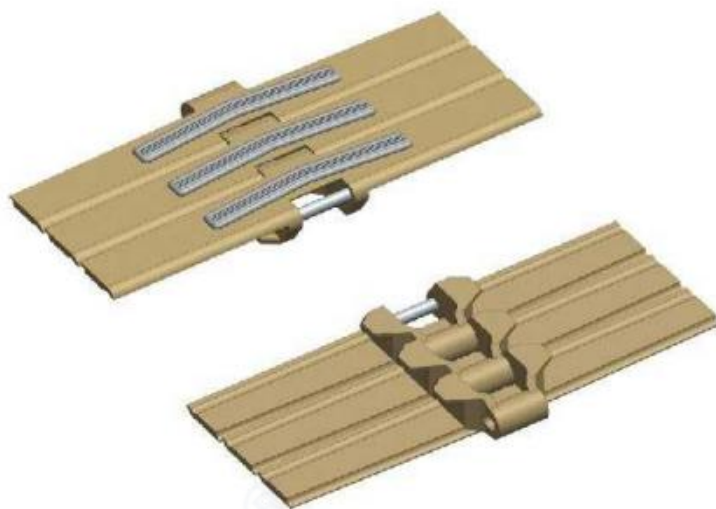

节距 Pitch	链板材质 Material	颜色 Color
38.1mm	POM	咖啡色/Brown

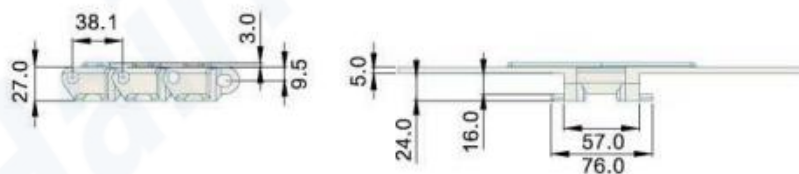
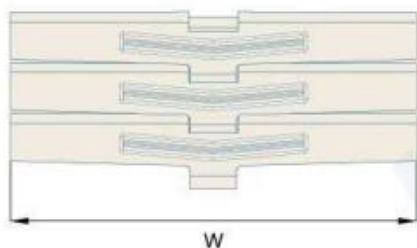

型号 Type No.	宽度 Width (mm)	节距 Pitch (mm)	重量 Weight (Kg/m)	转弯半径 Radius (mm)	负载 Working Capacity (N)
Har882TABF-K450	114.3	38.1	2.07	510	3830
Har882TABF-K750	190.5	38.1	2.19	610	3830
Har882TABF-K1000	254.0	38.1	2.81	610	3830
Har882TABF-K1200	304.8	38.1	3.04	610	3830

链轮 Sprocket	护栏 Guide	弯轨 Guide Rails	其余配件 Component
S19-S20	R01-R42	G04-G06	C01-C57

Har882 Series Straight TOP CHAINS

TOP CHAINS 882
P=38.1mm, T=19mm
PIN:Stainless steel

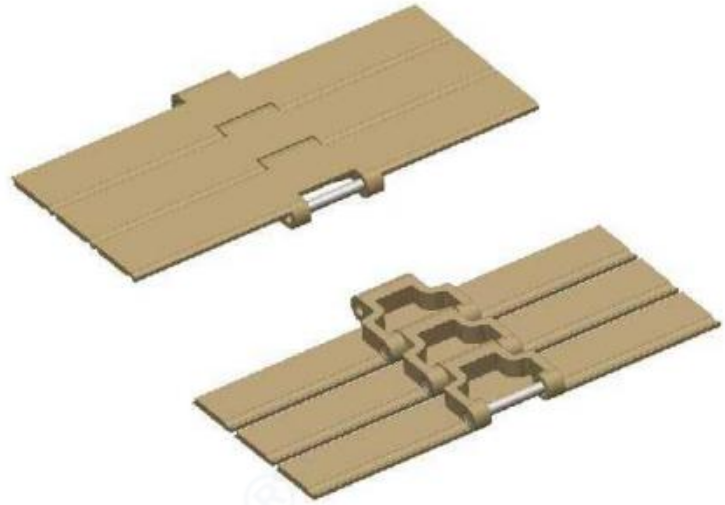

节距 Pitch	链板材质 Material	颜色 Color
38.1mm	POM	咖啡色/Brown



型号 Type No.	宽度 Width (mm)	节距 Pitch (mm)	重量 Weight (Kg/m)	负载 Working Capacity (N)
Har882-K750	190.5	38.1	2.16	3910
Har882-K1000	254.0	38.1	2.35	3910

链轮 Sprocket	护栏 Guide	弯轨 Guide Rails	其余配件 Component
S19-S20	R01-R42	—	C01-C57

Har882PRR Series Straight TOP CHAINS

TOP CHAINS 882PRR
P=38.1mm, T=34.5mm
PIN: Stainless Steel

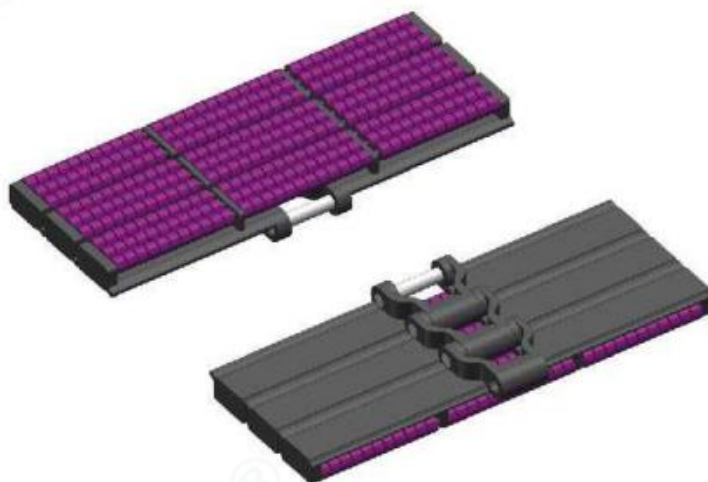

节距 Pitch	链板材质 Material	颜色 Color
38.1mm	POM	深灰色底/紫色滚珠 Dark Grey Plate/Purple Roller

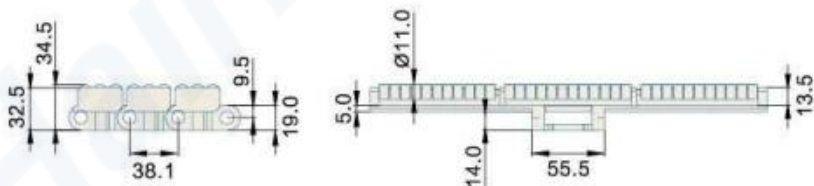

型号 Type No.	宽度 Width (mm)	节距 Pitch (mm)	重量 Weight (Kg/m)	负载 Working Capacity (N)
Har882PRR -K1000	254.0	38.1	7.2	3830

链轮 Sprocket	护栏 Guide	弯轨 Guide Rails	其余配件 Component
S19-S20	R01-R42	—	C01-C57

Har882FH Series Straight Rubber Cover

TOP CHAINS

TOP CHAINS 882FH Series
 P=38.1mm, T=18.5mm
 PIN:Stainless steel

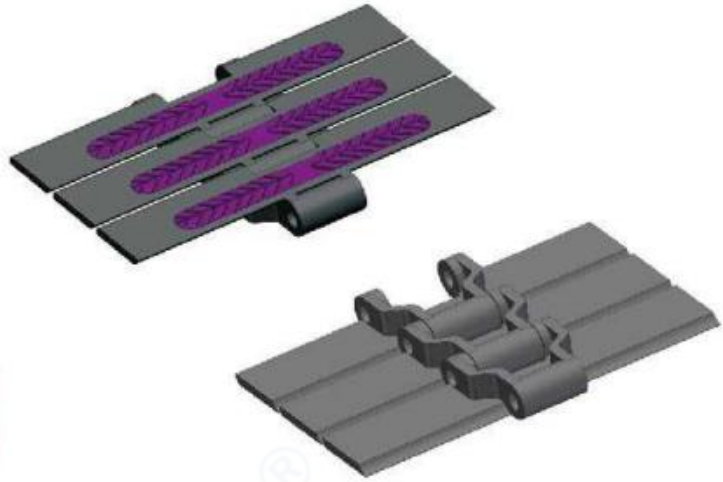

节距 Pitch	链板材质 Material	颜色 Color
38.1mm	POM	深灰紫胶/Dark Grey Plate Purple Rubber

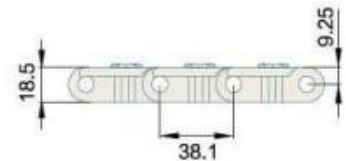
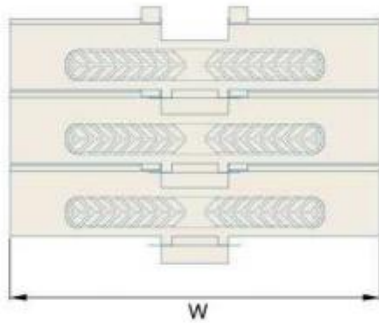

型号 Type No.	宽度 Width (mm)	节距 Pitch (mm)	重量 Weight (Kg/m)	负载 Working Capacity (N)
Har882FH-K750	190.5	38.1	2.10	2700
Har882FH-K1000	254.0	38.1	2.50	2700
Har882FH-K1200	304.8	38.1	2.70	2700

链轮 Sprocket	护栏 Guide	弯轨 Guide Rails	其余配件 Component
S19-S20	R01-R42	—	C01-C57

Har8P157G Series Curve

TOP CHAINS

TOP CHAINS 8P157G

P=38.1mm, T=8.5mm

PIN:Stainless steel



节距 Pitch	链板材质 Material	颜色 Color
38.1mm	POM	咖啡色/Brown

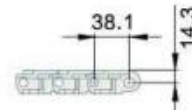
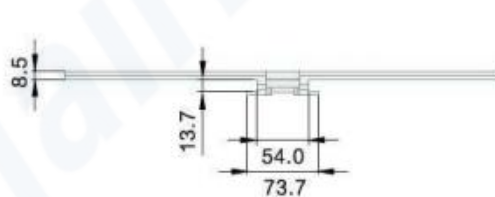
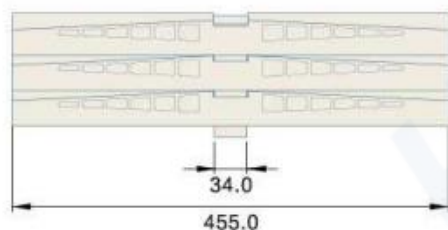

型号 Type No.	宽度 Width (mm)	节距 Pitch (mm)	重量 Weight (Kg/m)	转弯半径 Radius (mm)	负载 Working Capacity (N)
Har8P157	328	38.1	3.53	610	3830
Har8P157G	455	38.1	4.35	610	3830

链轮 Sprocket	护栏 Guide	弯轨 Guide Rails	其余配件 Component
—	R01-R42	—	C01-C57

Har1873/963 Series ROLLER CHAINS

ROLLER CHAINS 1873/963
P=19.05mm, T=18mm

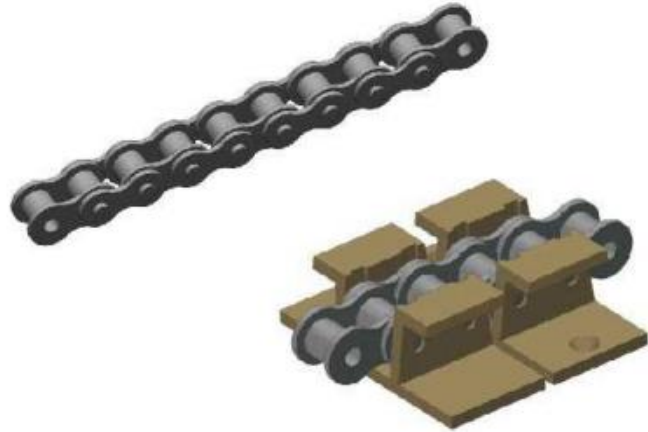

节距 Pitch	不锈钢材质 Material
19.05mm	SS304

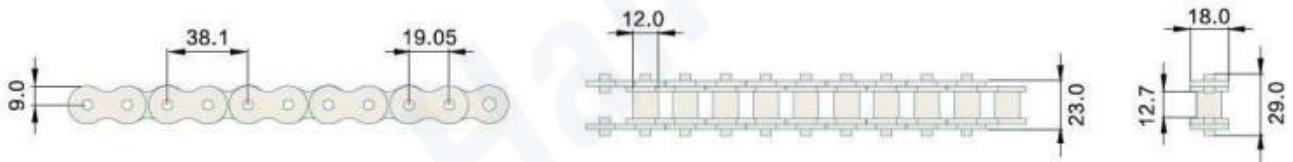

型号 Type No.	销轴长度 Length (mm)	节距 Pitch (mm)	重量 Weight (Kg/m)	侧转弯半径 Radius (mm)	负载 Working Capacity (N)
Har1873/963	29	19.05	2.1	810	2560

链轮 Sprocket	护栏 Guide	弯轨 Guide Rails	其余配件 Component
S35	R01-R42	—	C01-C57

Har843 Series Roller Chains ROLLER CHAINS

ROLLER CHAINS 843
P=12.7mm, T=11mm



节距 Pitch	链板材质 Material
12.7mm	SS304



型号 Type No.	销轴长度 Length (mm)	节距 Pitch (mm)	重量 Weight (Kg/m)	转弯半径 Radius (mm)	负载 Working Capacity (N)
Har843	17	12.7	0.85	—	2000

链轮 Sprocket	护栏 Guide	弯轨 Guide Rails	其余配件 Component
S17	R01-R42	—	C01-C57

Har843 Series TOP CHAINS

TOP CHAINS 843 Series
P=25.4mm, T=14.3mm

节距 Pitch	链板材质 Material	颜色 Color
25.4mm	POM	咖啡色/Brown

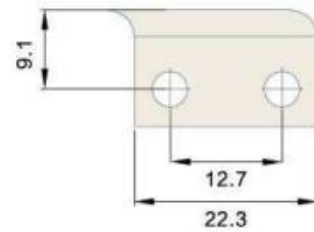
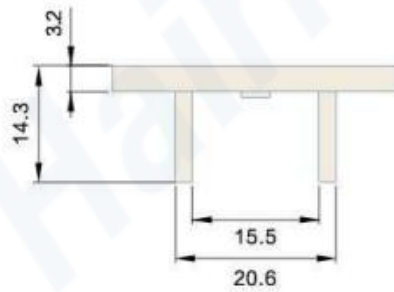
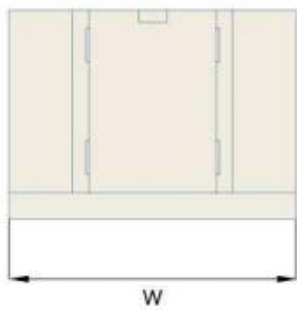
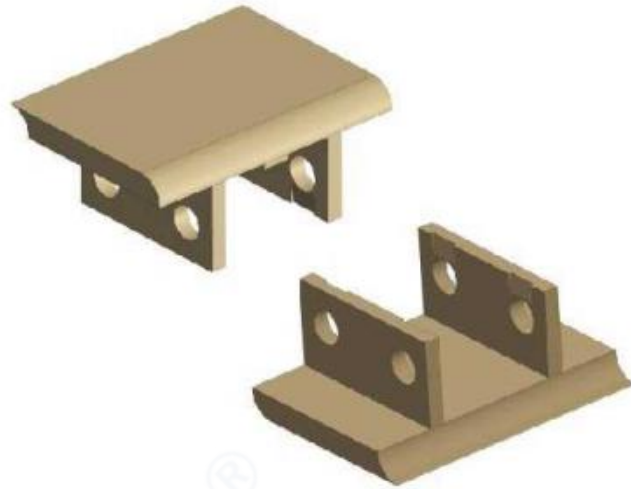

型号 Type No.	宽度 Width (mm)	节距 Pitch (mm)	重量 Weight (Kg/m)	负载 Working Capacity (N)
Har843-K138	34.9	25.4	0.69	2430
Har843-K200	50.8	25.4	0.75	2430
Har843-K325	82.6	25.4	0.82	2430

链轮 Sprocket	护栏 Guide	弯轨 Guide Rails	其余配件 Component
S17	R01-R42	—	C01-C57

Har845 Series Straight TOP CHAINS

TOP CHAINS 845
P=25.4mm, T=23.7mm

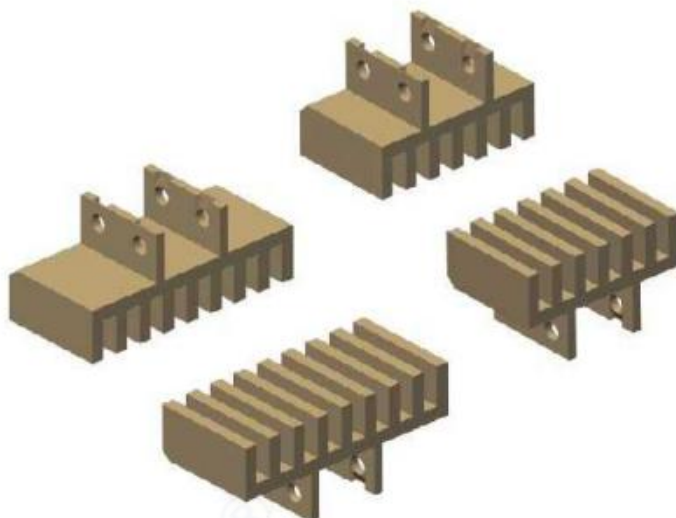

节距 Pitch	链板材质 Material	颜色 Color
25.4mm	POM	咖啡色/Brown

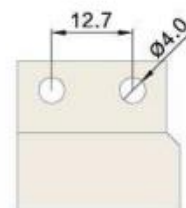
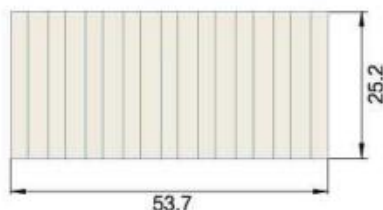
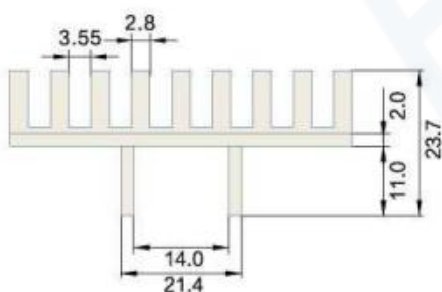
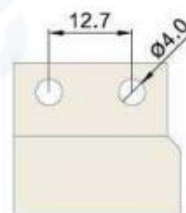
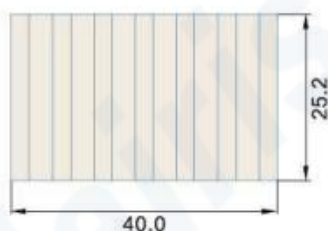
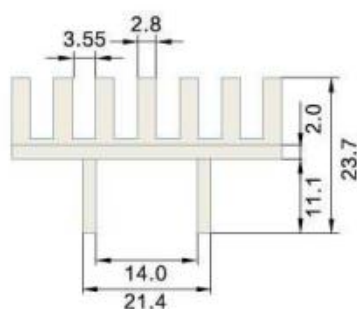

型号 Type No.	宽度 Width (mm)	节距 Pitch (mm)	重量 Weight (Kg/m)	负载 Working Capacity (N)
Har845-K157	40.0	25.4	1.0	3500
Har845-K200	53.7	25.4	1.1	3500

链轮 Sprocket	护栏 Guide	弯轨 Guide Rails	其余配件 Component
S17	R01-R42	—	C01-C57

Har963 Series Straight TOP CHAINS

TOP CHAINS 963
P=38.1mm, T=22mm

节距 Pitch	链板材质 Material	颜色 Color
38.1mm	POM	咖啡色/Brown

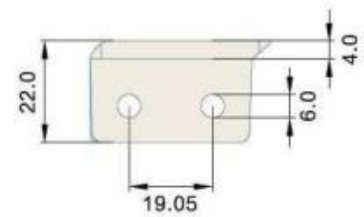
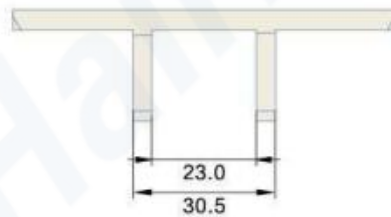
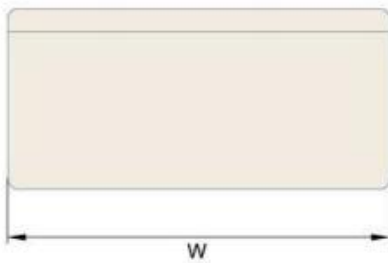
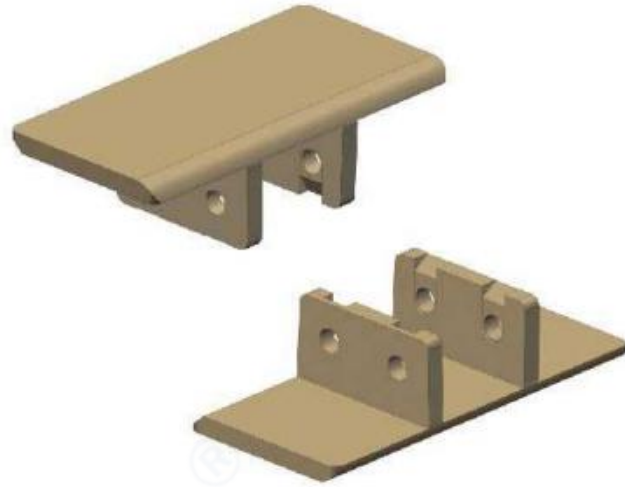

型号 Type No.	宽度 Width (mm)	节距 Pitch (mm)	重量 Weight (Kg/m)	负载 Working Capacity (N)
Har963-K325	82.6	38.1	2.10	4400
Har963-K450	114.3	38.1	2.30	4400
Har963-K1000	254.0	38.1	3.17	4400

链轮 Sprocket	护栏 Guide	弯轨 Guide Rails	其余配件 Component
S35	R01-R42	G08	C01-C57

Har963TAB Series Straight TOP CHAINS

TOP CHAINS 963TAB Series
P=38.1mm, T=4mm

节距 Pitch	链板材质 Material	颜色 Color
38.1mm	POM	咖啡色/Brown

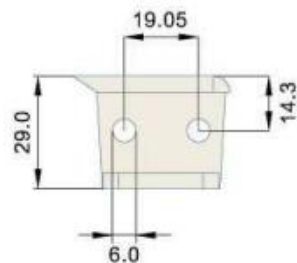
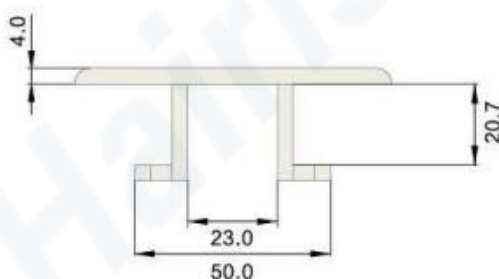
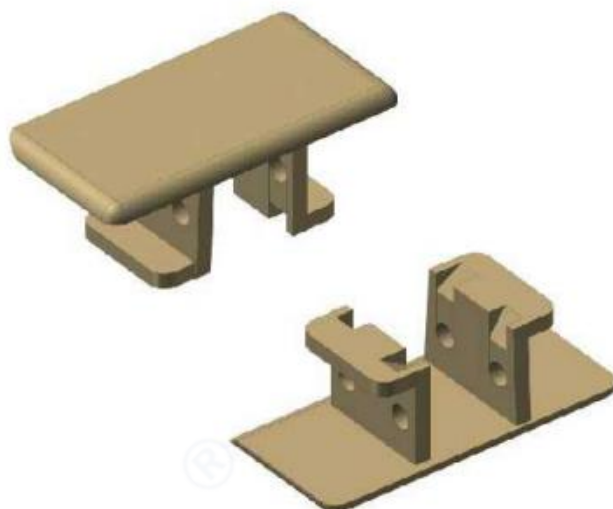

型号 Type No.	宽度 Width (mm)	节距 Pitch (mm)	重量 Weight (Kg/m)	负载 Working Capacity (N)
Har963TAB-K325	82.6	38.1	0.69	2560
Har963TAB-K450	114.3	38.1	0.75	2560
Har963TAB-K1000	254.0	38.1	1.10	2560

链轮 Sprocket	护栏 Guide	弯轨 Guide Rails	其余配件 Component
S35	R01-R42	G08	C01-C57

Har845 Series Straight TOP CHAINS

TOP CHAINS 845
P=25.4mm, T=3.2mm

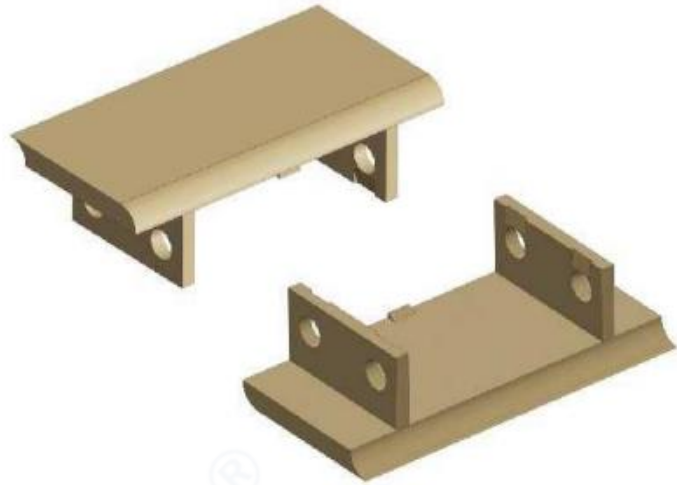

节距 Pitch	链板材质 Material	颜色 Color
25.4mm	POM	咖啡色/Brown

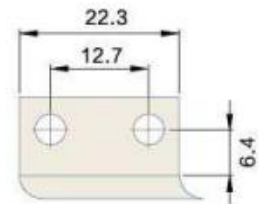
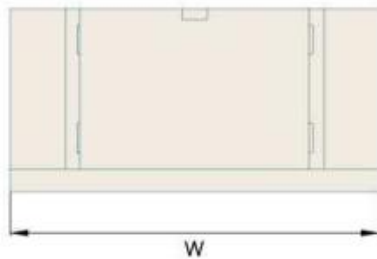

型号 Type No.	宽度 Width (mm)	节距 Pitch (mm)	重量 Weight (Kg/m)	负载 Working Capacity (N)
Har845-K138	34.9	25.4	0.84	2700
Har845-k200	50.8	25.4	0.90	2700
Har845-K325	82.6	25.4	1.03	2700

链轮 Sprocket	护栏 Guide	弯轨 Guide Rails	其余配件 Component
S17	R01-R42	—	C01-C57

Har1873-K375 Series Chain Plate

TOP CHAINS

TOP CHAINS 1873-K375
P=38.1mm, T=4mm

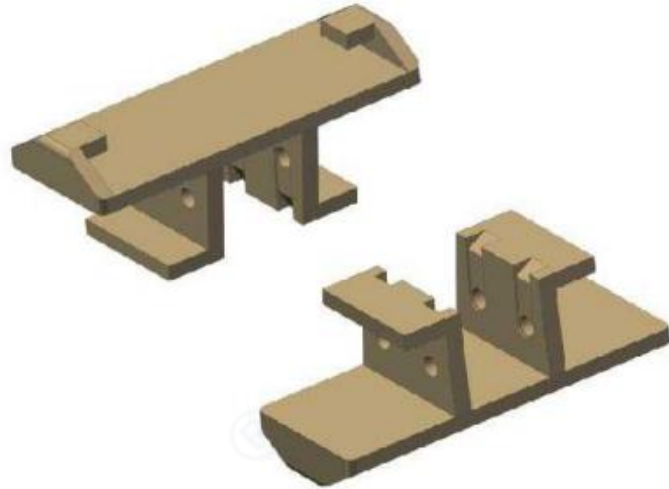

节距 Pitch	链板材质 Material	颜色 Color
38.1mm	POM	咖啡色/Brown

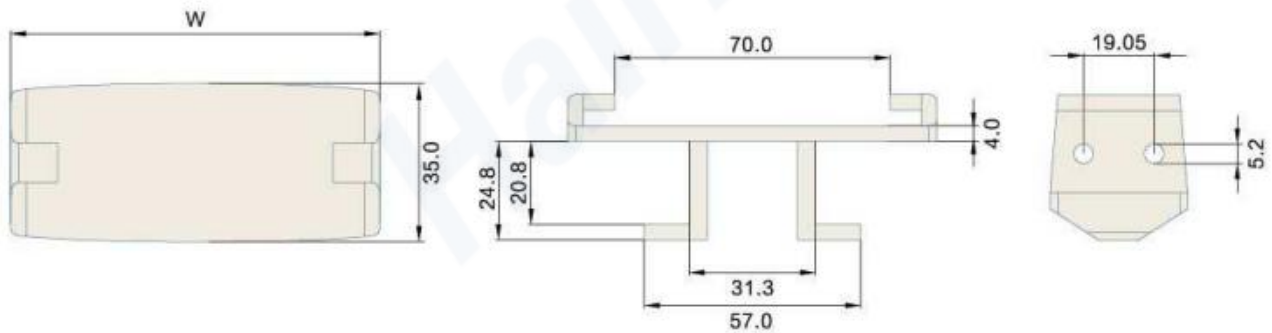

链板 Slat Top Chains

型号 Type No.	宽度 Width (mm)	节距 Pitch (mm)	重量 Weight (Kg/m)	负载 Working Capacity (N)
Har1873-K375	95.25	38.1	2.25	4400

链轮 Sprocket	护栏 Guide	弯轨 Guide Rails	其余配件 Component
S35	R01-R42	G08	C01-C57

Har1873TAB Series Curve TOP CHAINS

TOP CHAINS 1873TAB Series
P=38.1mm, T=29mm

节距 Pitch	链板材质 Material	颜色 Color
38.1mm	POM	咖啡色/Brown

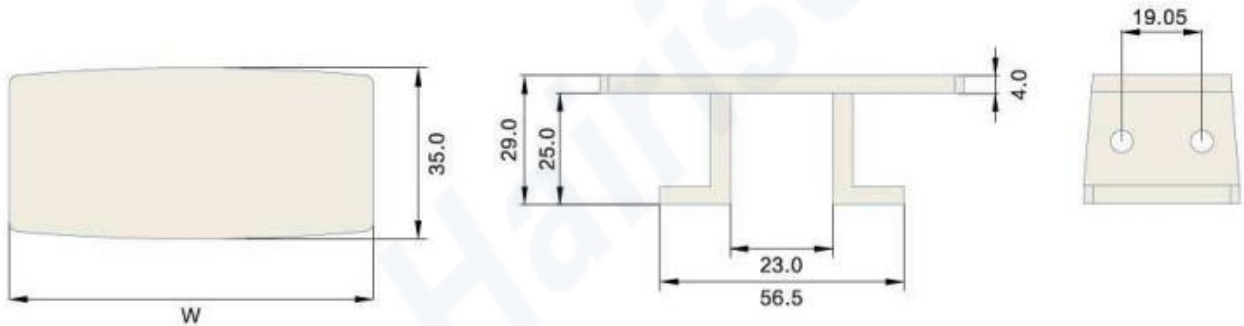
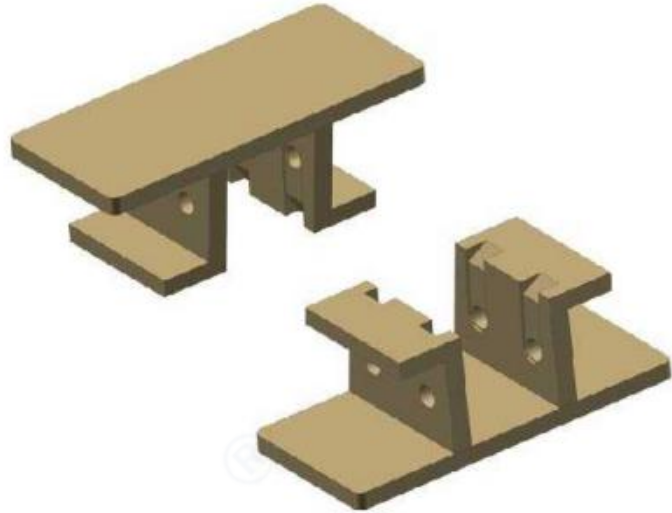

型号 Type No.	宽度 Width (mm)	节距 Pitch (mm)	重量 Weight (Kg/m)	负载 Working Capacity (N)
Har1873TAB-K325	82.6	38.1	2.10	2560
Har1873TAB-K450	114.3	38.1	2.26	2560
Har1873TAB-K600	152.4	38.1	2.41	2560
Har1873TAB-K750	190.5	38.1	2.56	2560
Har1873TAB-K1000	254.0	38.1	2.78	2560
Har1873TAB-K1200	304.8	38.1	3.01	2560

链轮 Sprocket	护栏 Guide	弯轨 Guide Rails	其余配件 Component
S35	R01-R42	G08	C01-C57

Har1873FHC Series Curve

TOP CHAINS

TOP CHAINS 1873FHC
P=38.1mm, T=7mm

节距 Pitch	链板材质 Material	颜色 Color
38.1mm	POM	咖啡色/Brown

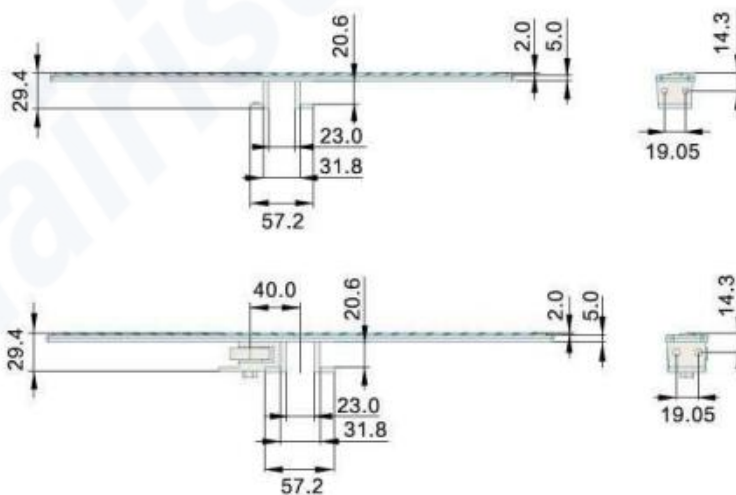
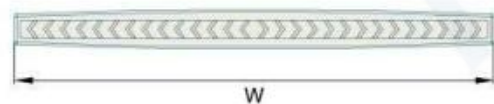
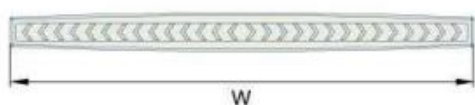
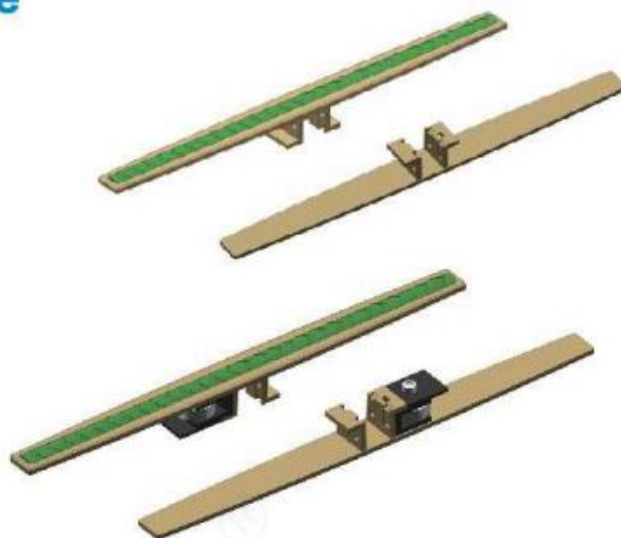

型号 Type No.	宽度 Width (mm)	节距 Pitch (mm)	重量 Weight (Kg/m)	负载 Working Capacity (N)
Har1873FHC-K1200	304.8	38.1	3.58	2680
Har1873FHC-K1600	406.8	38.1	3.78	2680
Har1873FHC-K1800	457.2	38.1	3.98	2680

链轮 Sprocket	护栏 Guide	弯轨 Guide Rails	其余配件 Component
S35	R01-R42	G08	C01-C57

Har1873FA-403 Series TOP CHAINS

TOP CHAINS 1873FA
P=38.1mm, T=30mm



节距 Pitch	链板材质 Material	颜色 Color
38.1mm	POM	黑色/Black



型号 Type No.	宽度 Width (mm)	节距 Pitch (mm)	重量 Weight (Kg/m)	负载 Working Capacity (N)
Har1873FA-403	403	38.1	4.0	4400

链轮 Sprocket	护栏 Guide	弯轨 Guide Rails	其余配件 Component
S35	R01-R42	G08	C01-C57

Har1873FA-508 Series

TOP CHAINS

TOP CHAINS 1873FA

P=38.1mm, T=30mm



节距 Pitch	链板材质 Material	颜色 Color
38.1mm	POM	黑色/Black

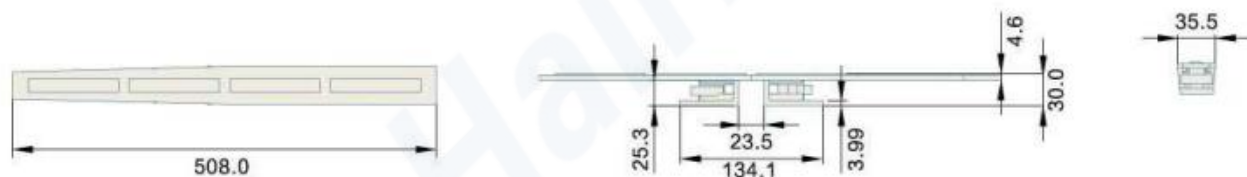

型号 Type No.	宽度 Width (mm)	节距 Pitch (mm)	重量 Weight (Kg/m)	负载 Working Capacity (N)
Har1873FA-508	508.0	38.1	4.5	4400
Har1873FA-600	600.0	38.1	6.5	4400

链轮 Sprocket	护栏 Guide	弯轨 Guide Rails	其余配件 Component
S35	R01-R42	G08	C01-C57

Har1873-E Series Curve TOP CHAINS

TOP CHAINS 1873-E
P=38.1mm, T=6mm



节距 Pitch	链板材质 Material	颜色 Color
38.1mm	POM	咖啡色/Brown

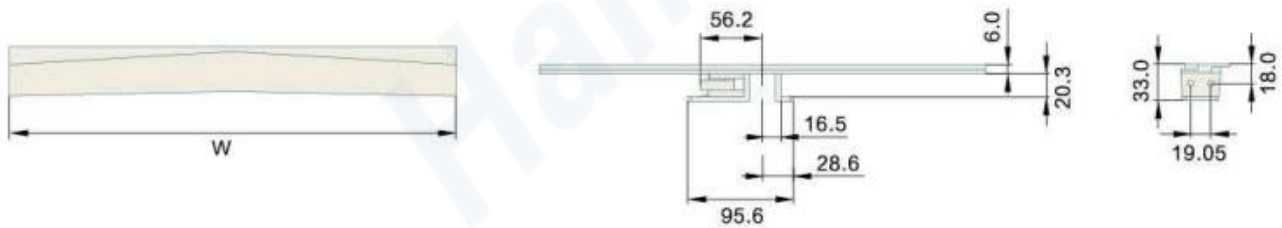

型号 Type No.	宽度 Width (mm)	节距 Pitch (mm)	重量 Weight (Kg/m)	负载 Working Capacity (N)
Har1873-E-K1000	254.0	38.1	4.30	3200
Har1873-E-K1200	304.8	38.1	4.70	3200

链轮 Sprocket	护栏 Guide	弯轨 Guide Rails	其余配件 Component
S35	R01-R42	G08	C01-C57

Har1873GJ Series Curve

TOP CHAINS

TOP CHAINS 1873GJ Series
P=38.1mm, T=4mm

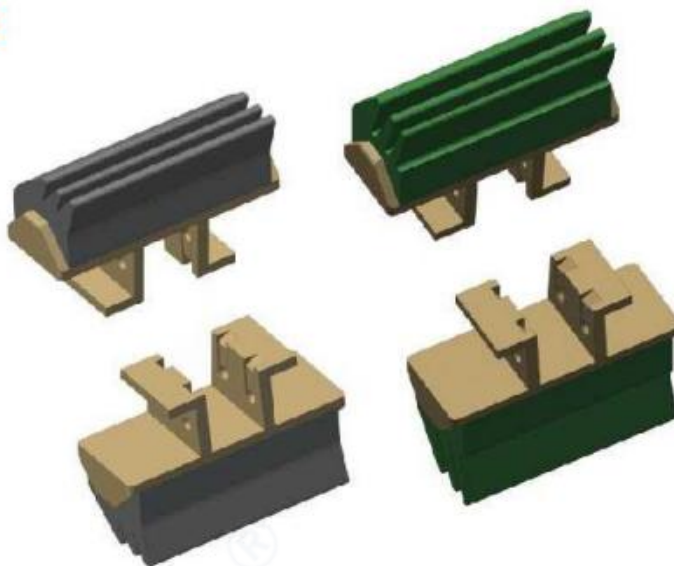

节距 Pitch	链板材质 Material	颜色 Color
38.1mm	POM	咖啡色/Brown

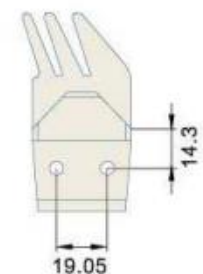
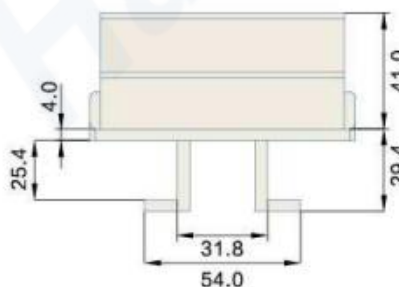
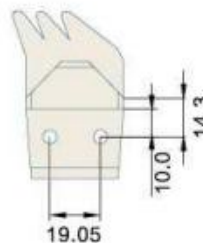
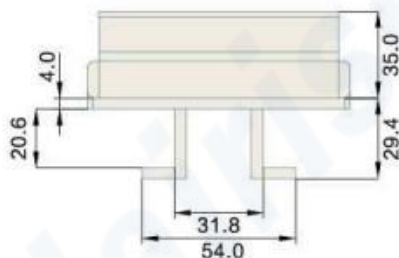

型号 Type No.	宽度 Width (mm)	节距 Pitch (mm)	重量 Weight (Kg/m)	负载 Working Capacity (N)
Har1873GJ-K325	82.6	38.1	4.2	3500
Har1873GJ-K375	95.2	38.1	4.4	3500
Har1873GJ-K450	114.3	38.1	4.5	3500

链轮 Sprocket	护栏 Guide	弯轨 Guide Rails	其余配件 Component
S35	R01-R42	G08	C01-C57

Har1873D Series Curve Rubber Cover

TOP CHAINS

TOP CHAINS 1873D Series
P=38.1mm, T=59mm

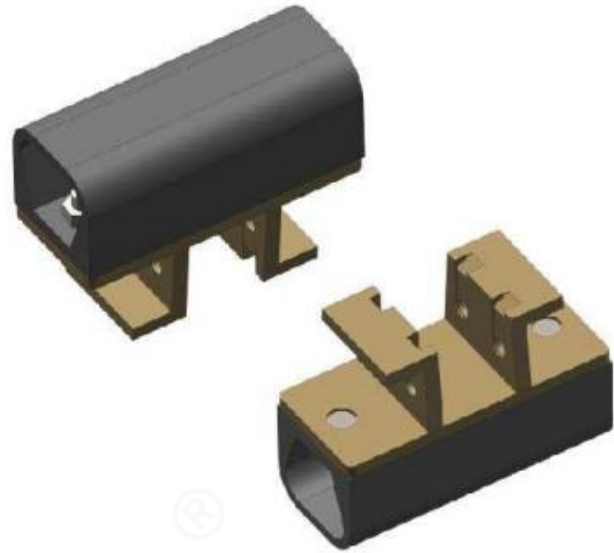

节距 Pitch	链板材质 Material	颜色 Color
38.1mm	POM	咖啡色/Brown

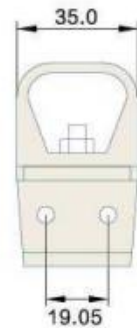
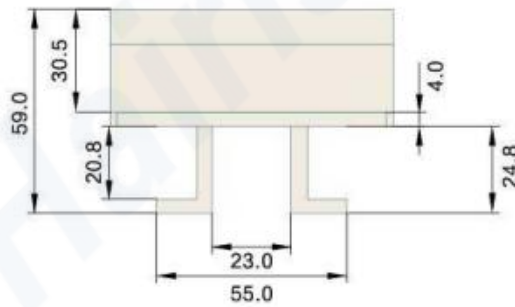

型号 Type No.	宽度 Width (mm)	节距 Pitch (mm)	重量 Weight (Kg/m)	负载 Working Capacity (N)
Har1873D-K325	82.6	38.1	2.90	2560
Har1873D-K375	95.3	38.1	3.10	2560
Har1873D-K450	114.3	38.1	3.40	2560
Har1873D-K600	152.4	38.1	3.60	2560
Har1873D-K750	190.5	38.1	3.90	2560

链轮 Sprocket	护栏 Guide	弯轨 Guide Rails	其余配件 Component
S35	R01-R42	G08	C01-C57

Har1873GJ Series Curve Rubber Cover

TOP CHAINS

TOP CHAINS 1873GJ Series
P=38.1mm, T=28.7mm

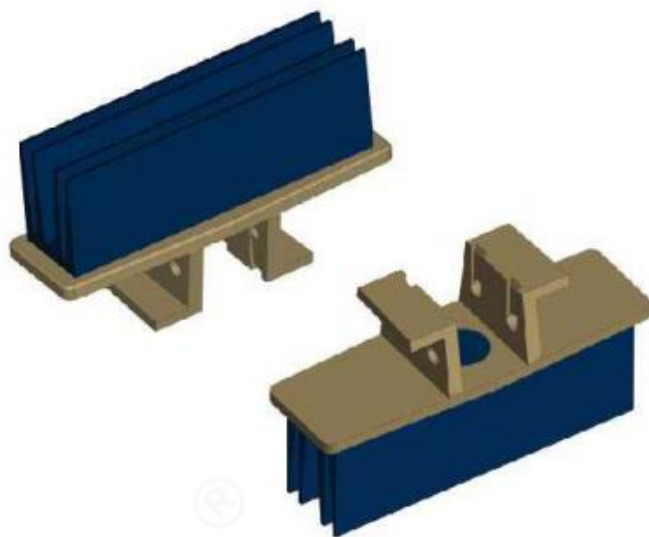

节距 Pitch	链板材质 Material	颜色 Color
38.1 mm	POM	棕色底板黑色胶/ Brown Plate Black Rubber

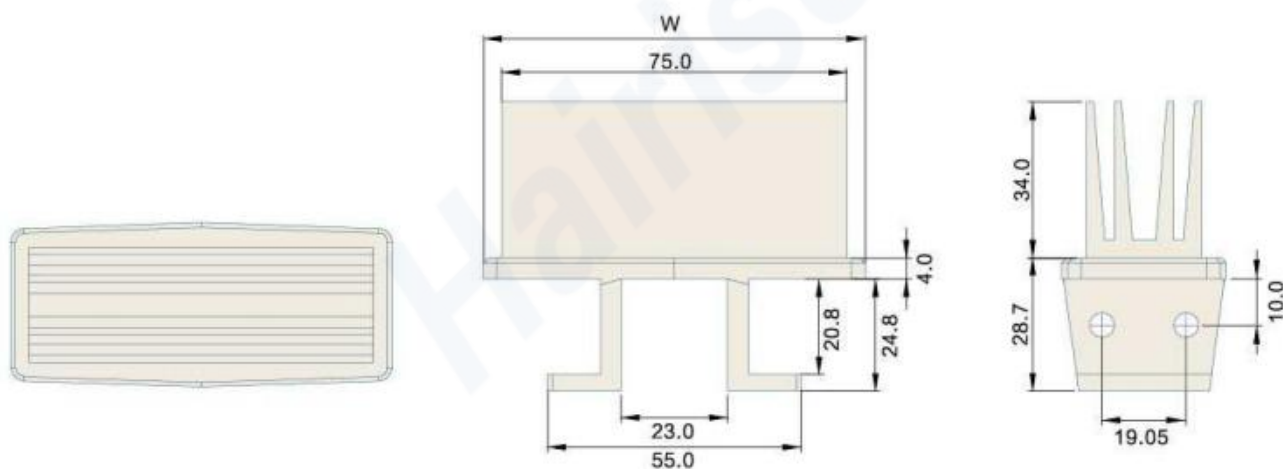

型号 Type No.	宽度 Width (mm)	节距 Pitch (mm)	重量 Weight (Kg/m)	负载 Working Capacity (N)
Har1873GJ-K325	82.6	38.1	3.20	2560
Har1873GJ-K450	114.3	38.1	3.40	2560

链轮 Sprocket	护栏 Guide	弯轨 Guide Rails	其余配件 Component
S35	R01-R42	G08	C01-C57

Har1050 Series Curve TOP CHAINS

TOP CHAINS 1050 Series
P=25.4mm, T=8.7mm
PIN:Stainless steel
Curve Radius:600mm



节距 Pitch	链板材质 Material	颜色 Color
25.4mm	POM	墨绿色/Dark Green

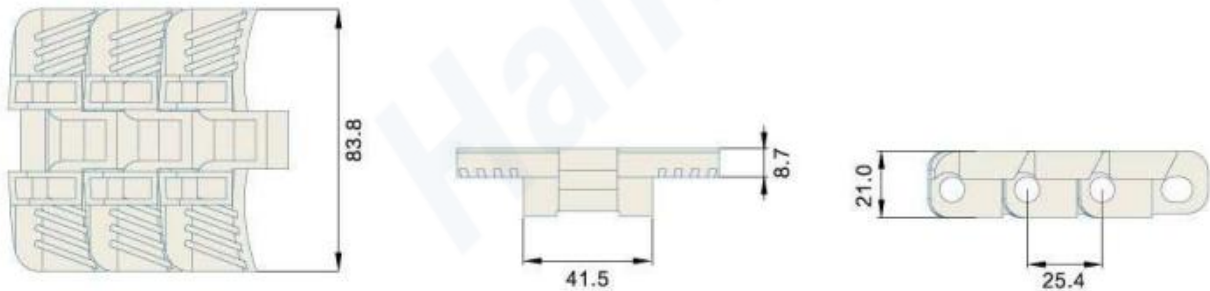

型号 Type No.	宽度 Width (mm)	节距 Pitch (mm)	重量 Weight (Kg/m)	转弯半径 Radius (mm)	负载 Working Capacity (N)
Har1050	83.8	25.4	1.68	600	3800

链轮 Sprocket	护栏 Guide	弯轨 Guide Rails	其余配件 Component
S26-S27	R01-R42	G07	C01-C57

Har1050TAB Series Curve

TOP CHAINS

TOP CHAINS 1050TAB

P=25.4mm, T=8.7mm

PIN:Stainless steel

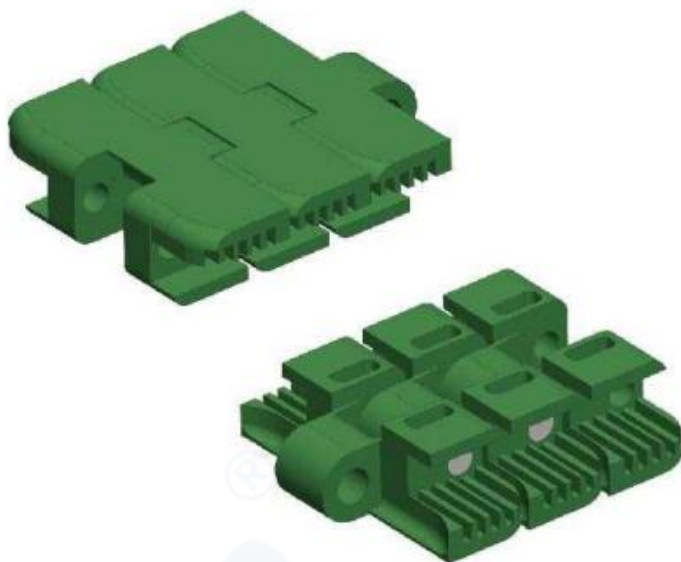

节距 Pitch	链板材质 Material	颜色 Color
25.4mm	POM	墨绿色/Dark Green

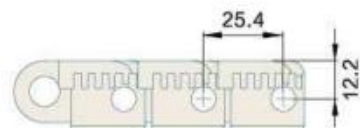
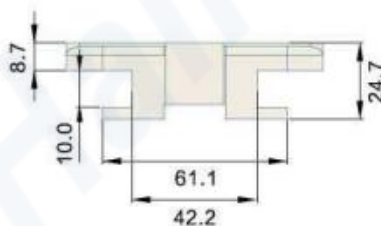
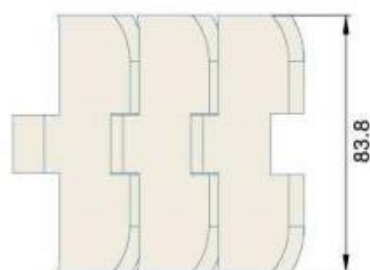

型号 Type No.	宽度 Width (mm)	节距 Pitch (mm)	重量 Weight (Kg/m)	转弯半径 Radius (mm)	负载 Working Capacity (N)
Har1050TAB-K330	83.8	25.4	1.68	600	3800

链轮 Sprocket	护栏 Guide	弯轨 Guide Rails	其余配件 Component
S26-S27	R01-R42	—	C01-C57

Har1060 Series Curve TOP CHAINS

TOP CHAINS 1060 Series
P=25.4mm, T=8.7mm
PIN:Stainless steel



节距 Pitch	链板材质 Material	颜色 Color
25.4mm	POM	深灰色/Dark Gray

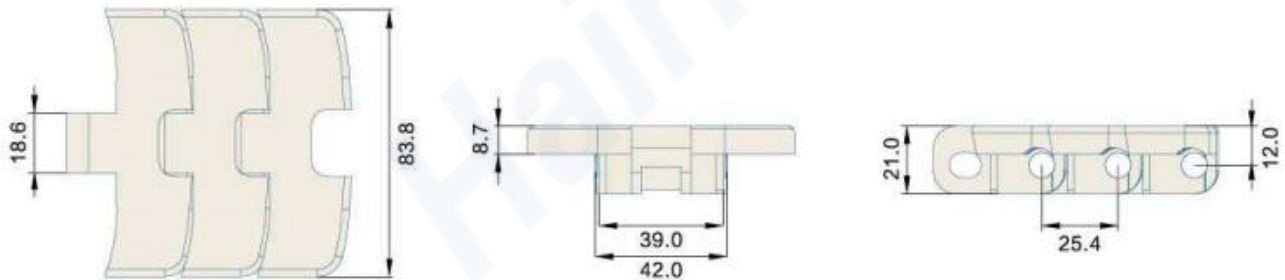

型号 Type No.	宽度 Width (mm)	节距 Pitch (mm)	重量 Weight (Kg/m)	转弯半径 Radius (mm)	负载 Working Capacity (N)
Har1060-K330	83.8	25.4	1.68	600	3800

链轮 Sprocket	护栏 Guide	弯轨 Guide Rails	其余配件 Component
S26-S27	R01-R42	G07	C01-C57

Har1050FG Series

TOP CHAINS

TOP CHAINS 1050 Series

P=25.4mm, T=21.2mm

OPEN AREA:10%

PIN:Stainless steel



节距 Pitch	链板材质 Material	颜色 Color
25.4mm	POM	墨绿色/Dark Green

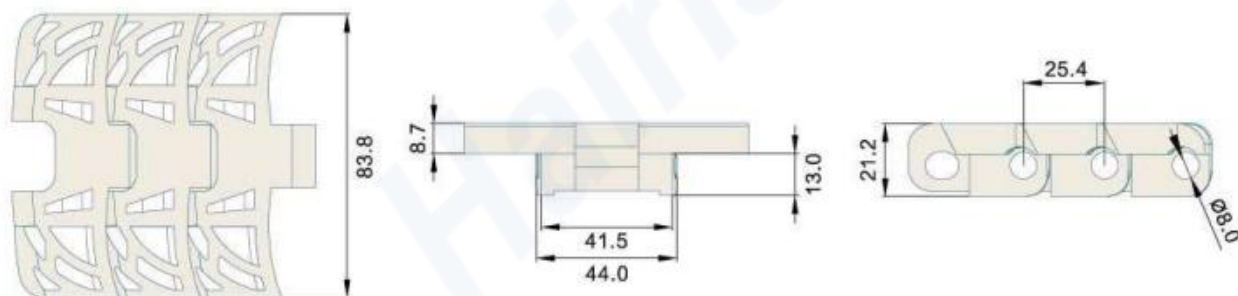

型号 Type No.	宽度 Width (mm)	节距 Pitch (mm)	重量 Weight (Kg/m)	转弯半径 Radius (mm)	负载 Working Capacity (N)
Har1050FG-K330	83.8	25.4	1.55	600	1650

链轮 Sprocket	护栏 Guide	弯轨 Guide Rails	其余配件 Component
S26-S27	R01-R42	G07	C01-C57

HarNH78 Series Straight TOP CHAINS

TOP CHAINS NH78 Series
P=66mm, T=28mm
PIN:Stainless steel



节距 Pitch	链板材质 Material	颜色 Color
66mm	POM	咖啡色/Brown 黑色/black

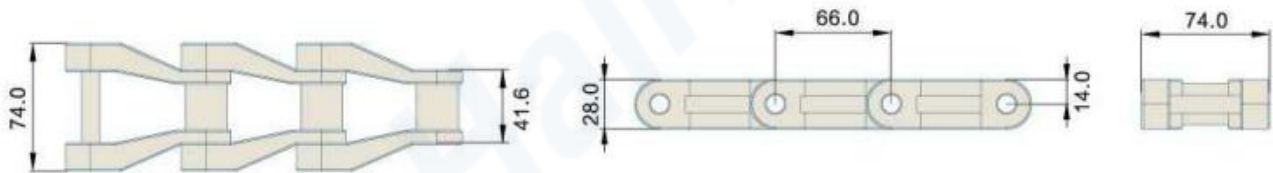

型号 Type No.	宽度 Width (mm)	节距 Pitch (mm)	重量 Weight (Kg/m)	负载 Working Capacity (N)
HarNH78	74	66	2.76	3970

链轮 Sprocket	护栏 Guide	弯轨 Guide Rails	其余配件 Component
—	R01-R42	—	C01-C57

Har8825 Series

TOP CHAINS

TOP CHAINS 8825
 P=38.1mm, T=30.5mm
 PIN:Stainless steel

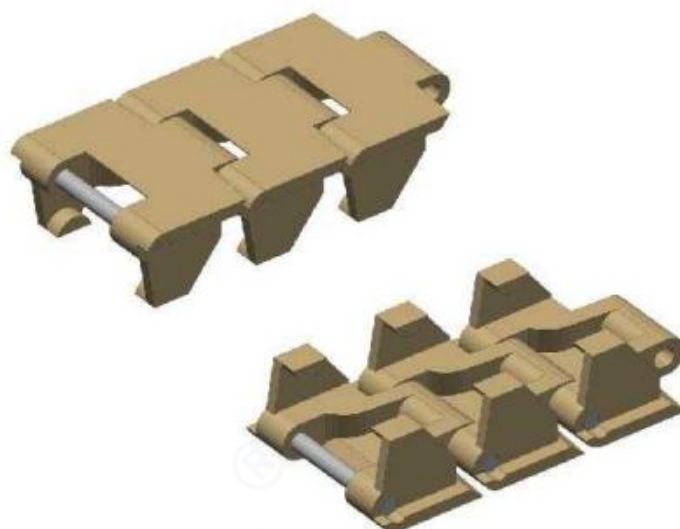

节距 Pitch	链板材质 Material	颜色 Color
38.1mm	POM	咖啡色/Brown

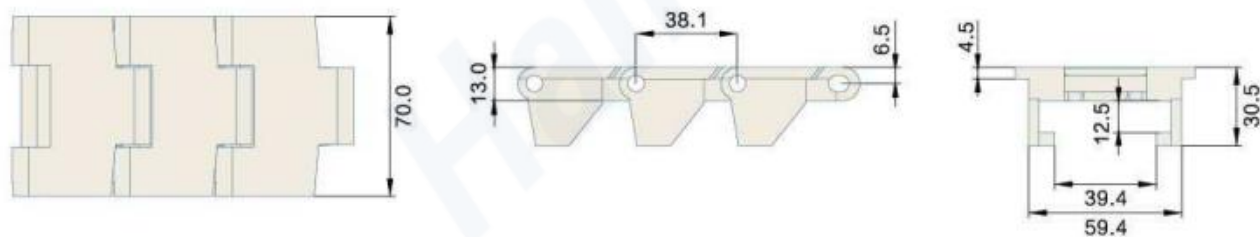

链板 Slat Top Chains

型号 Type No.	宽度 Width (mm)	节距 Pitch (mm)	重量 Weight (Kg/m)	负载 Working Capacity (N)
Har8825	70	38.1	1.22	2100

链轮 Sprocket	护栏 Guide	弯轨 Guide Rails	其余配件 Component
S66	R01-R42	—	C01-C57

Har8827 Series Straight TOP CHAINS

TOP CHAINS 8827
P=38.1mm, T=29.4mm
PIN:Stainless steel

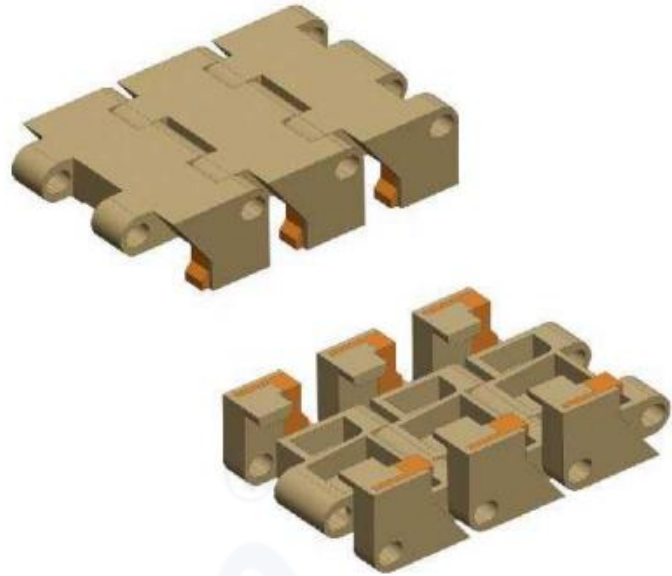

节距 Pitch	链板材质 Material	颜色 Color
38.1mm	POM	咖啡色/Brown

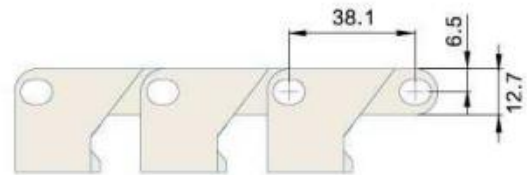
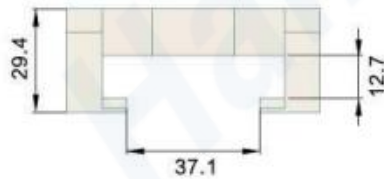

型号 Type No.	宽度 Width (mm)	节距 Pitch (mm)	重量 Weight (Kg/m)	负载 Working Capacity (N)
Har8827	71.7	38.1	0.971	2100

链轮 Sprocket	护栏 Guide	弯轨 Guide Rails	其余配件 Component
—	R01-R42	—	C01-C57

Har8828 Series Curve

TOP CHAINS

TOP CHAINS 8828
 P=38.1mm, T=65.5mm
 PIN:Stainless steel

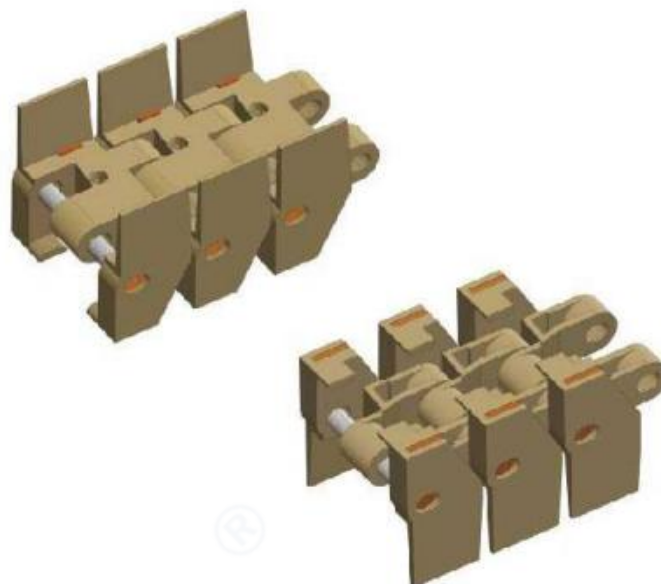

节距 Pitch	链板材质 Material	颜色 Color
38.1mm	POM	咖啡色/Brown

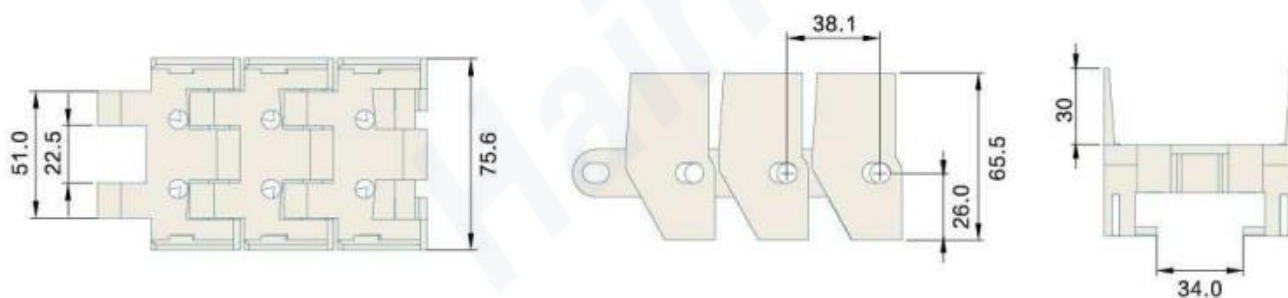

型号 Type No.	宽度 Width (mm)	节距 Pitch (mm)	重量 Weight (Kg/m)	负载 Working Capacity (N)
Har8828	75.6	38.1	1.58	2100

链轮 Sprocket	护栏 Guide	弯轨 Guide Rails	其余配件 Component
—	R01-R42	—	C01-C57

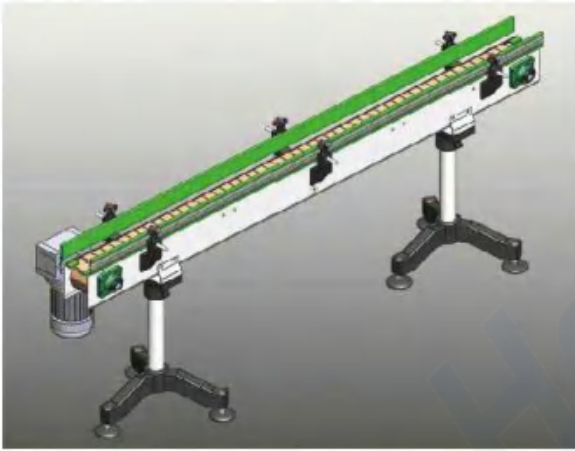

Har802 Series TOP CHAINS

TOP CHAINS 802
P=38.1mm, T=3mm

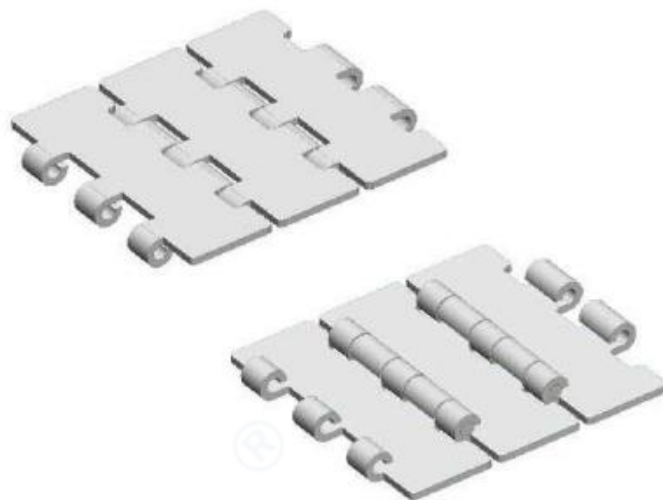

节距 Pitch	链板材质 Material
38.1mm	SS304/2CR13

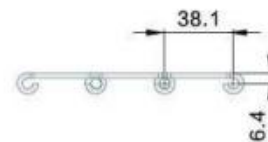
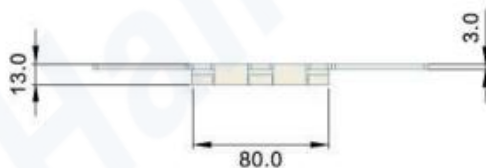
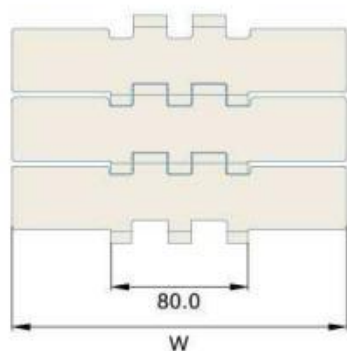

型号 Type No.	宽度 Width (mm)	节距 Pitch (mm)	重量 Weight (Kg/m)	转弯半径 Radius (mm)	负载 Working Capacity (N)
Har802-K750	190.5	38.1	5.61	—	10600
Har802-K1000	254.0	38.1	7.48	—	10600
Har802-K1200	304.8	38.1	9.00	—	10600

链轮 Sprocket	护栏 Guide	弯轨 Guide Rails	其余配件 Component
S14-S16	R01-R42	—	C01-C57

Har812 Series TOP CHAINS

TOP CHAINS 812 Series
P=38.1mm, T=13mm
PIN:Stainless steel

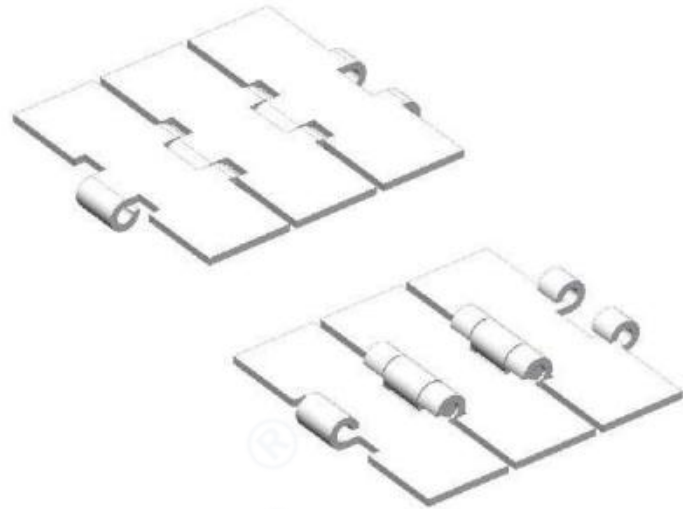

节距 Pitch	链板材质 Material
38.1mm	SS304/2CR13

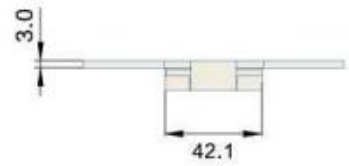
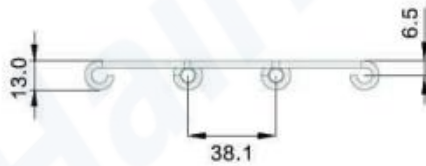
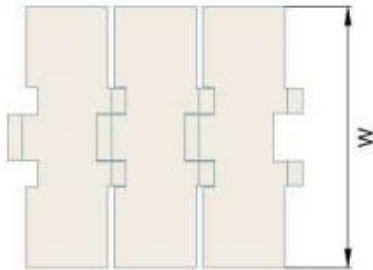

型号 Type No.	宽度 Width (mm)	节距 Pitch (mm)	重量 Weight (Kg/m)	转弯半径 Radius (mm)	负载 Working Capacity (N)
Har812-K250	63.5	38.1	1.55	—	4000
Har812-K325	82.6	38.1	2.86	—	4000
Har812-K450	114.3	38.1	3.50	—	4000
Har812-K600	152.4	38.1	4.40	—	4000
Har812-K750	190.5	38.1	5.20	—	4000

链轮 Sprocket	护栏 Guide	弯轨 Guide Rails	其余配件 Component
S09-S11	R01-R42	G01	C01-C57

Har812FH Series Straight Rubber Cover

TOP CHAINS

TOP CHAINS 812FH Series

P=38.1mm, T=15mm

PIN:Stainless steel

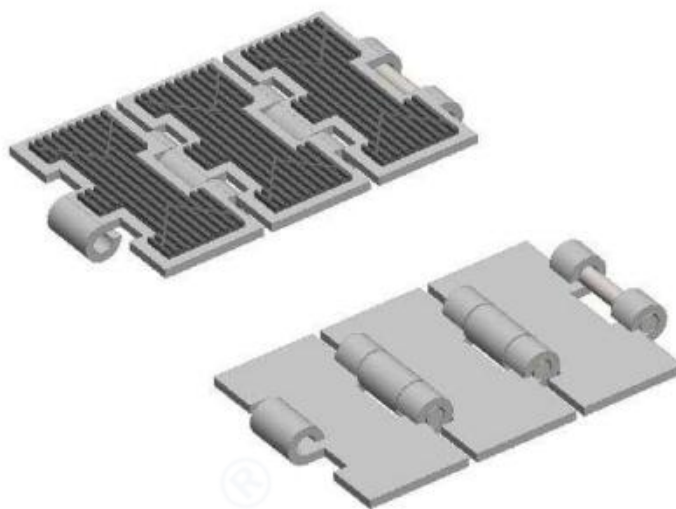

节距 Pitch	链板材质 Material
38.1 mm	SS304/2CR13

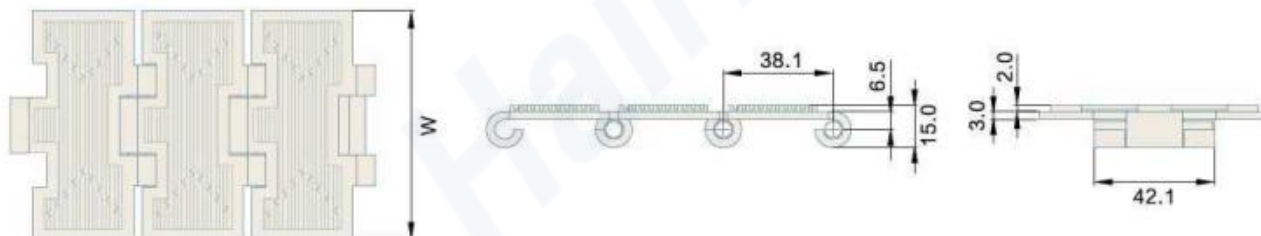

型号 Type No.	宽度 Width (mm)	节距 Pitch (mm)	重量 Weight (Kg/m)	转弯半径 Radius (mm)	负载 Working Capacity (N)
Har812FH-K325	82.6	38.1	3.1	—	4000
Har812FH-K750	190.5	38.1	5.5	—	4000

链轮 Sprocket	护栏 Guide	弯轨 Guide Rails	其余配件 Component
S09-S11	R01-R42	—	C01-C57

Har981T Series TOP CHAINS

TOP CHAINS 981T
P=38.1mm, T=3mm

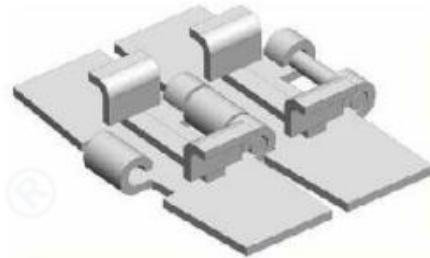
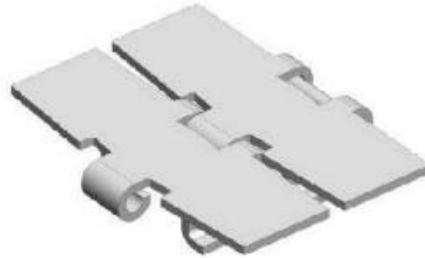

节距 Pitch	链板材质 Material
38.1mm	SS304/2CR13

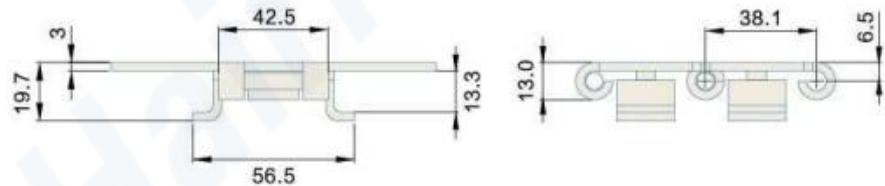
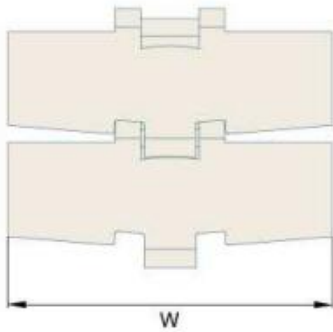

型号 Type No.	宽度 Width (mm)	节距 Pitch (mm)	重量 Weight (Kg/m)	转弯半径 Radius (mm)	负载 Working Capacity (N)
Har981T-K325	82.6	38.1	2.97	610	6000
Har981T-K450	114.3	38.1	3.61	610	6000
Har981T-K750	190.5	38.1	5.05	610	6000

链轮 Sprocket	护栏 Guide	弯轨 Guide Rails	其余配件 Component
S23	R01-R42	—	C01-C57

Har981M Series

TOP CHAINS

TOP CHAINS 981M
P=38.1mm, T=3mm

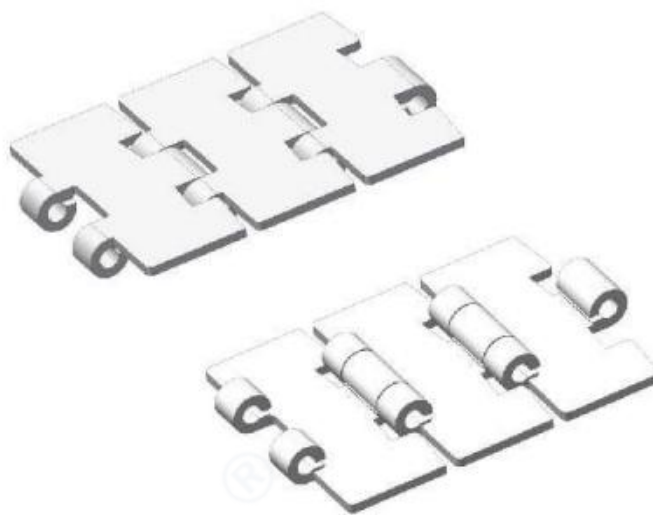

节距 Pitch	链板材质 Material
38.1mm	SS304/2CR13

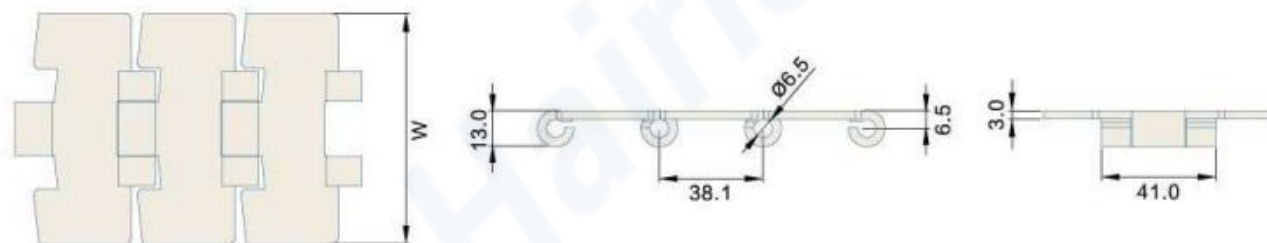

型号 Type No.	宽度 Width (mm)	节距 Pitch (mm)	重量 Weight (Kg/m)	转弯半径 Radius (mm)	负载 Working Capacity (N)
Har981M-K325	82.6	38.1	2.5	610	5400
Har981M-K450	114.3	38.1	3.1	610	5400
Har981M-K750	190.5	38.1	4.5	610	5400

链轮 Sprocket	护栏 Guide	弯轨 Guide Rails	其余配件 Component
S23	R01-R42	G07	C01-C57

Har981M FH Series TOP CHAINS

TOP CHAINS 981M FH
P=38.1mm, T=5.5mm

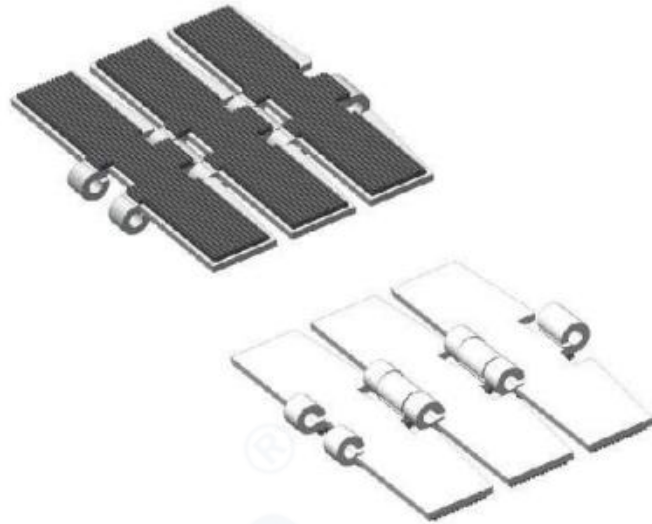

节距 Pitch	链板材质 Material
38.1mm	SS304/2CR13

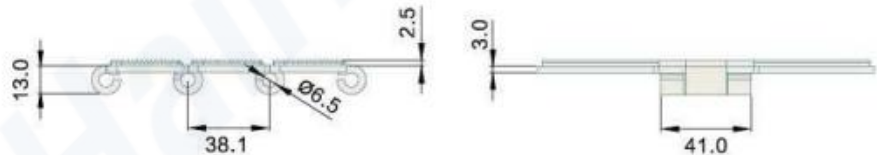
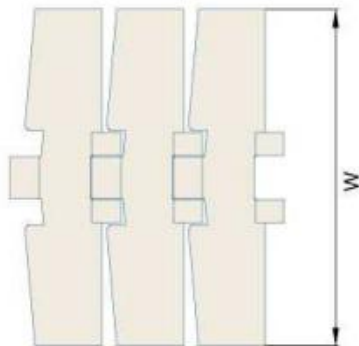

型号 Type No.	宽度 Width (mm)	节距 Pitch (mm)	重量 Weight (Kg/m)	转弯半径 Radius (mm)	负载 Working Capacity (N)
Har981M FH-K325	82.6	38.1	2.8	610	5400
Har981M FH-K450	114.3	38.1	3.4	610	5400
Har981M FH-K750	190.5	38.1	4.8	610	5400

链轮 Sprocket	护栏 Guide	弯轨 Guide Rails	其余配件 Component
S23	R01-R42	G07	C01-C57

Har515 Series TOP CHAINS

MULTIFLEX CHAINS 515 Series
P=25.4 mm, T=13mm
PIN:Stainless steel

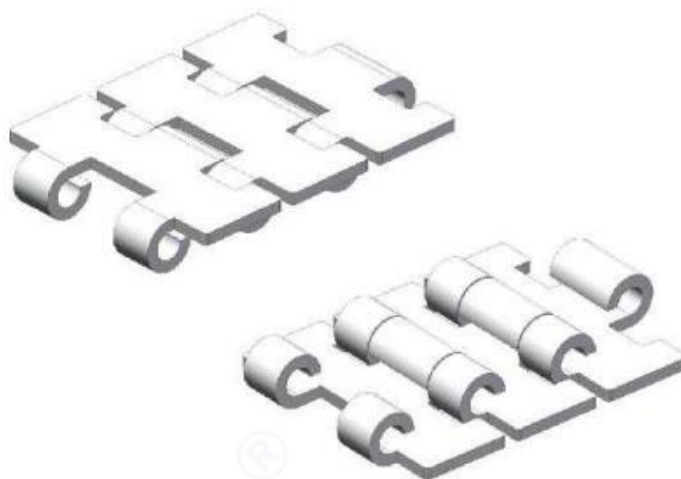

节距 Pitch	链板材质 Material
25.4mm	SS304/2CR13

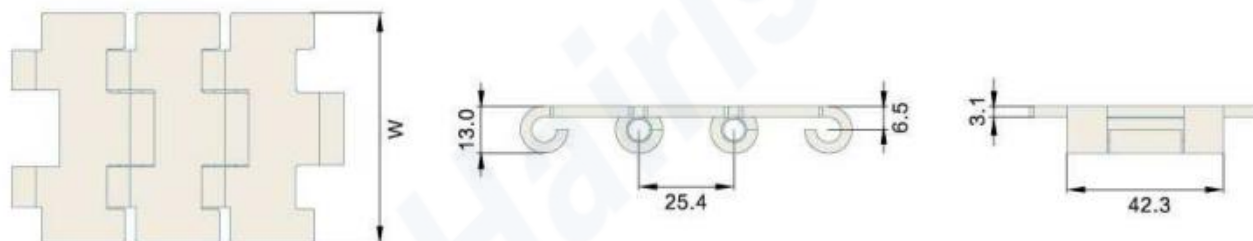

型号 Type No.	宽度 Width (mm)	节距 Pitch (mm)	重量 Weight (Kg/m)	转弯半径 Radius (mm)	负载 Working Capacity (N)
Har515-K197	50.0	25.4	2.10	—	4000
Har515-K217	55.0	25.4	2.30	—	4000
Har515-K236	60.0	25.4	2.45	—	4000
Har515-K283	72.0	25.4	2.80	—	4000

链轮 Sprocket	护栏 Guide	弯轨 Guide Rails	其余配件 Component
S06	R01-R42	—	C01-C57

Packing Machine Roller Chain

ROLLER CHAIN

ROLLER CHAIN
P=15.875mm, T=15mm



节距 Pitch	不锈钢材质 Material
15.875mm	POM

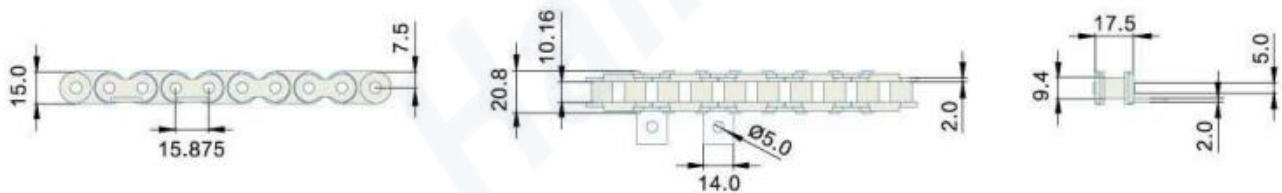

型号 Type No.	宽度 Width (mm)	节距 Pitch (mm)	重量 Weight (Kg/m)	转弯半径 Radius (mm)	负载 Working Capacity (N)
PACKING MACHINE ROLLER CHAIN	20.8	15.875	0.51	—	4320

链轮 Sprocket	护栏 Guide	弯轨 Guide Rails	其余配件 Component
—	—	—	—

Har600 Series FLEXIBLE CHAINS

FLEXIBLE CHAINS 600
P=63.5mm, T=28.5mm
PIN:Stainless steel

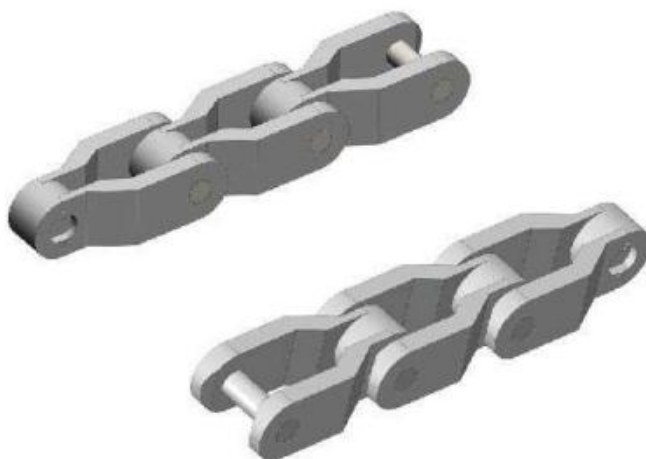

节距 Pitch	链板材质 Material	颜色 Color
63.5mm	POM	白色/White

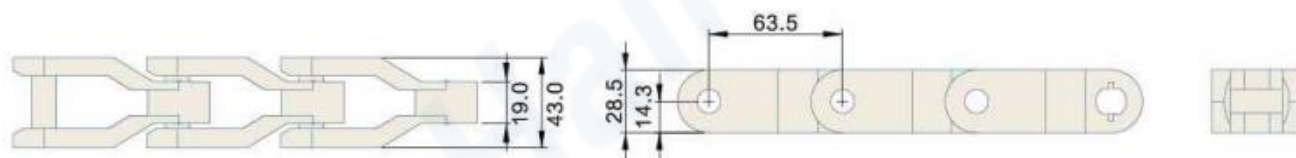

型号 Type No.	宽度 Width (mm)	节距 Pitch (mm)	重量 Weight (Kg/m)	转弯半径 Radius (mm)	负载 Working Capacity (N)
Har600	43.0	63.5	1.2	457	4000

链轮 Sprocket	护栏 Guide	弯轨 Guide Rails	其余配件 Component
S07	R01-R42	—	C01-C57

Har600TAB Series FLEXIBLE CHAINS

FLEXIBLE CHAINS 600TAB
P=63.5mm, T=28.5mm
PIN:Stainless steel

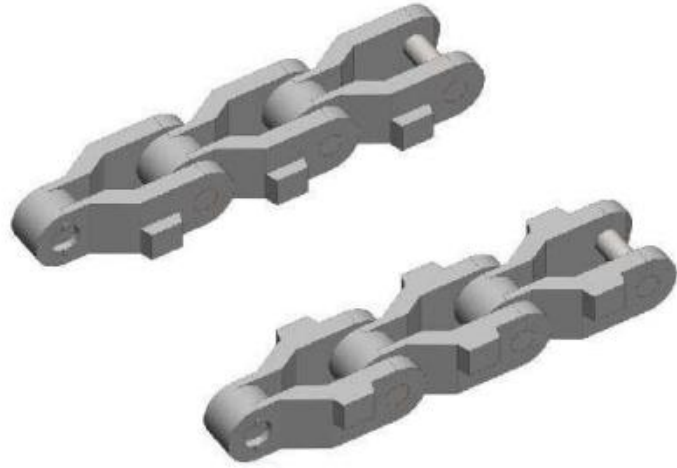

节距 Pitch	链板材质 Material	颜色 Color
63.5mm	POM	白色/White



型号 Type No.	宽度 Width (mm)	节距 Pitch (mm)	重量 Weight (Kg/m)	转弯半径 Radius (mm)	负载 Working Capacity (N)
Har600TAB	43.0	63.5	1.4	457	4000

链轮 Sprocket	护栏 Guide	弯轨 Guide Rails	其余配件 Component
S07	R01-R42	—	C01-C57

Har1400TAB Series

FLEXIBLE CHAINS

FLEXIBLE CHAINS 1400TAB

P=82.5mm, T=38mm

PIN:Stainless steel

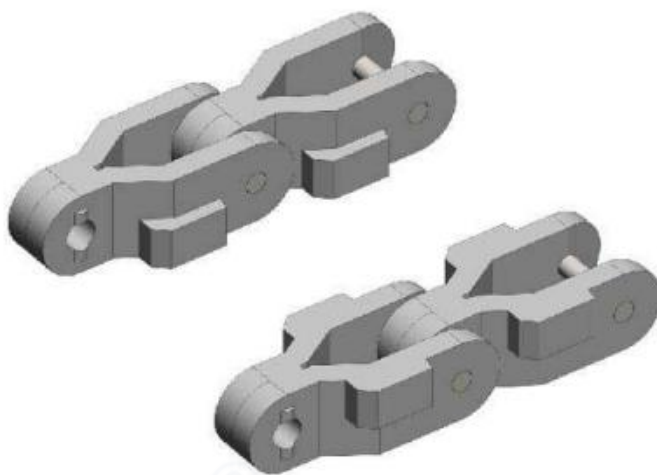

节距 Pitch	链板材质 Material	颜色 Color
82.5mm	POM	白色/White

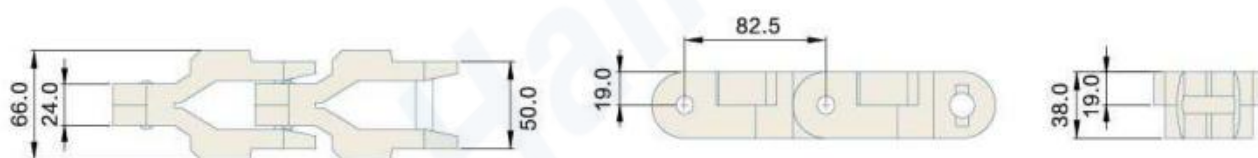

型号 Type No.	宽度 Width (mm)	节距 Pitch (mm)	重量 Weight (Kg/m)	转弯半径 Radius (mm)	负载 Working Capacity (N)
Har1400TAB	50.0	82.5	2.26	600	4700

链轮 Sprocket	护栏 Guide	弯轨 Guide Rails	其余配件 Component
S29	R01-R42	—	C01-C57

Har1610 Series FLEXIBLE CHAINS

FLEXIBLE CHAINS 1610
P=63.5mm, T=48mm
PIN:Stainless steel

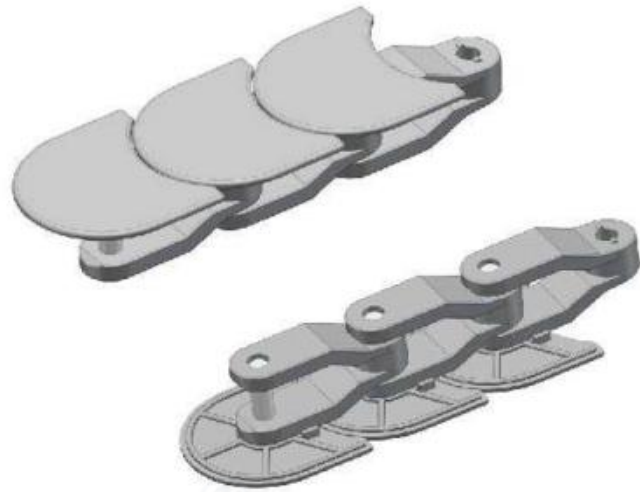

节距 Pitch	链板材质 Material	颜色 Color
63.5mm	POM	白色/White

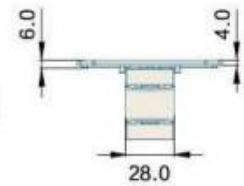
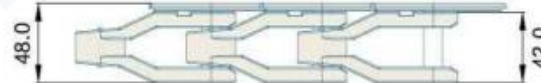
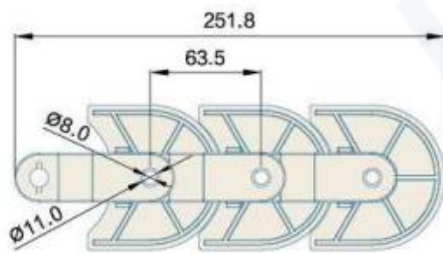
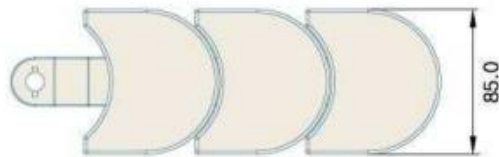

型号 Type No.	宽度 Width (mm)	节距 Pitch (mm)	重量 Weight (Kg/m)	转弯半径 Radius (mm)	负载 Working Capacity (N)
Har1610	85.0	63.5	1.76	150	3000

链轮 Sprocket	护栏 Guide	弯轨 Guide Rails	其余配件 Component
S34	R01-R42	—	C01-C57

Har1700 Series FLEXIBLE CHAINS

FLEXIBLE CHAINS 1700
P=50.0mm, T=23.9mm
PIN:Stainless steel

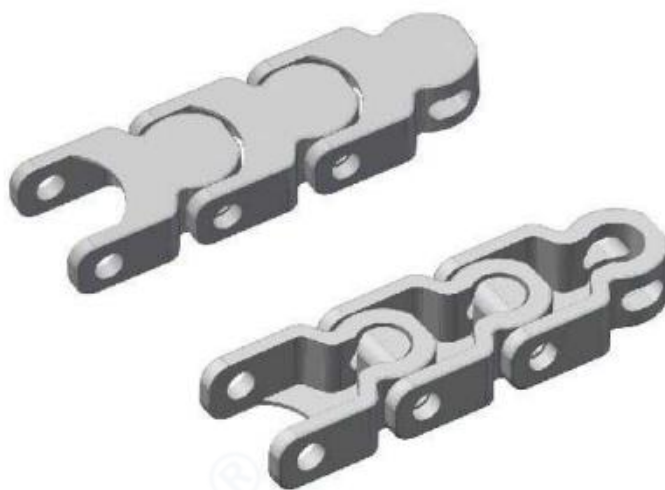

节距 Pitch	链板材质 Material	颜色 Color
50.0mm	POM	白色/White

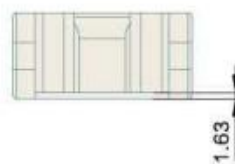
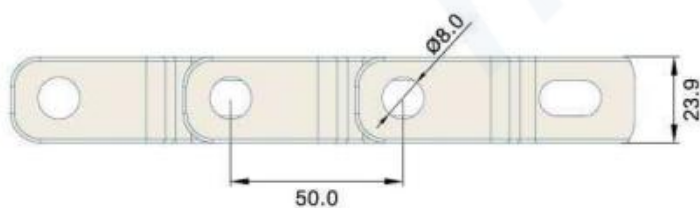
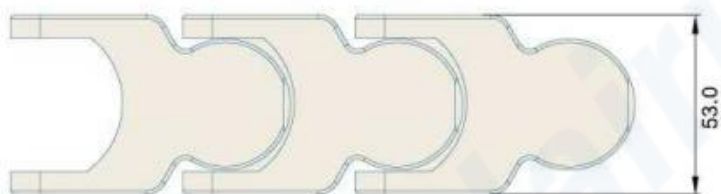

型号 Type No.	宽度 Width (mm)	节距 Pitch (mm)	重量 Weight (Kg/m)	转弯半径 Radius (mm)	负载 Working Capacity (N)
Har1700	53.0	50.0	1.4	250.0	4000

链轮 Sprocket	护栏 Guide	弯轨 Guide Rails	其余配件 Component
S34	R01-R42	G09	C01-C57

Har1700TAB Series FLEXIBLE CHAINS

FLEXIBLE CHAINS 1700TAB
P=50mm, T=23.9mm
PIN:Stainless steel

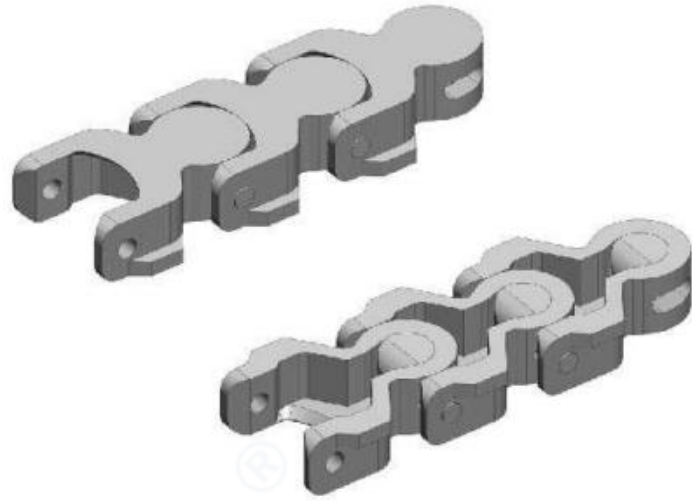

节距 Pitch	链板材质 Material	颜色 Color
50mm	POM	白色/White

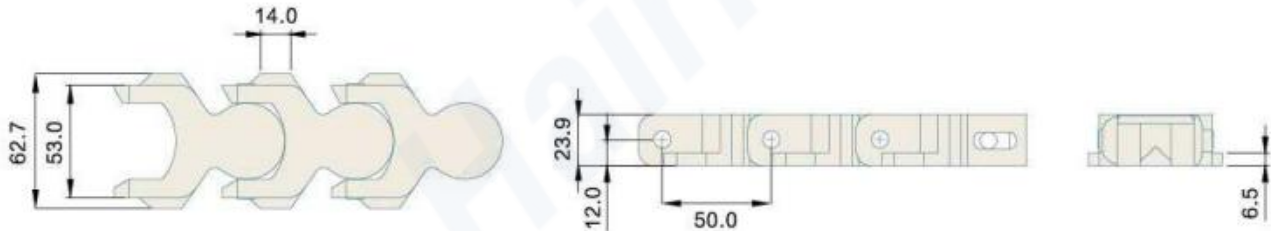

型号 Type No.	宽度 Width (mm)	节距 Pitch (mm)	重量 Weight (Kg/m)	转弯半径 Radius (mm)	负载 Working Capacity (N)
Har1700TAB	53.0	50	1.6	250	4000

链轮 Sprocket	护栏 Guide	弯轨 Guide Rails	其余配件 Component
S34	R01-R42	G09	C01-C57

Har1701/1705 Series FLEXIBLE CHAINS

FLEXIBLE CHAINS 1701/1705
P=50.0mm, T=24.0mm
PIN:Stainless steel

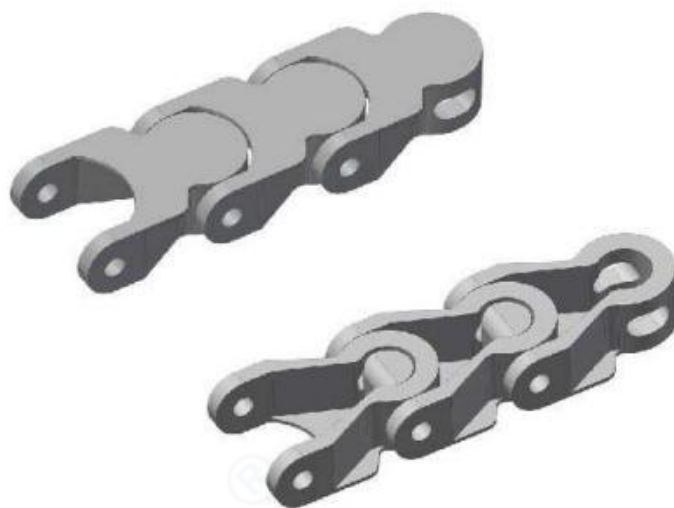

节距 Pitch	链板材质 Material	颜色 Color
50.0mm	POM	白色/White

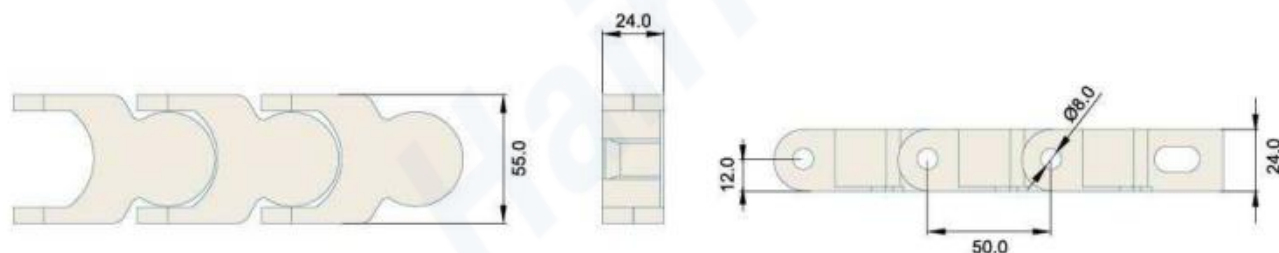

型号 Type No.	宽度 Width (mm)	节距 Pitch (mm)	重量 Weight (Kg/m)	转弯半径 Radius (mm)	负载 Working Capacity (N)
Har1701/1705	55.0	50.0	1.27	250	4000

链轮 Sprocket	护栏 Guide	弯轨 Guide Rails	其余配件 Component
S34	R01-R42	—	C01-C57

Har042680 Series FLEXIBLE CHAINS

FLEXIBLE CHAINS 042680
P=30.0mm, T=23.5mm
PIN:Stainless steel

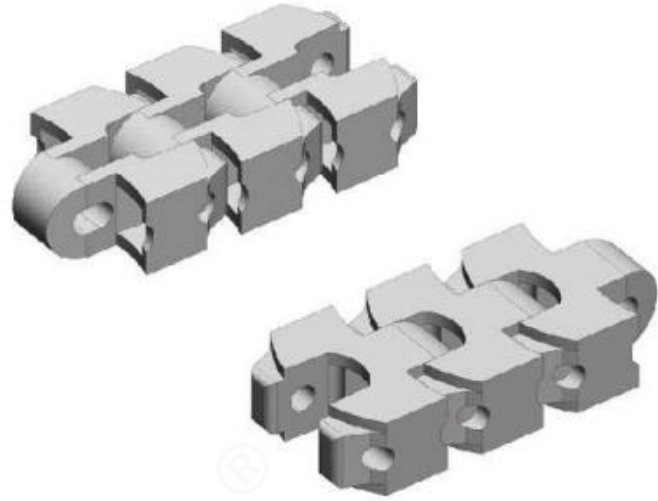

节距 Pitch	链板材质 Material	颜色 Color
30.0mm	POM	白色/White

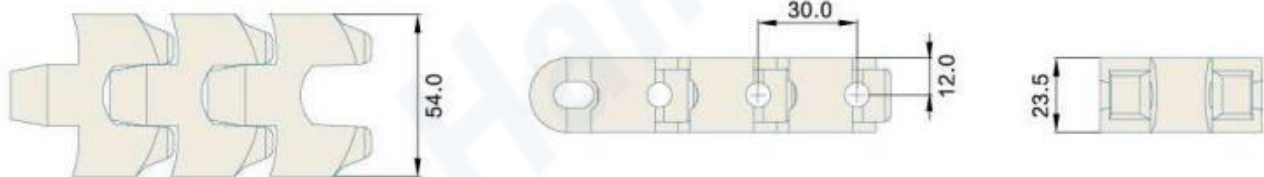

型号 Type No.	宽度 Width (mm)	节距 Pitch (mm)	重量 Weight (Kg/m)	转弯半径 Radius (mm)	负载 Working Capacity (N)
Har042680	54.0	30.0	1.62	250	2200

链轮 Sprocket	护栏 Guide	弯轨 Guide Rails	其余配件 Component
S66	R01-R42	—	C01-C57

Har216618 Series

FLEXIBLE CHAINS

FLEXIBLE CHAINS 216618

P=25.4mm, T=22mm

PIN:Stainless steel



节距 Pitch	链板材质 Material	颜色 Color
25.4mm	POM	白色/White

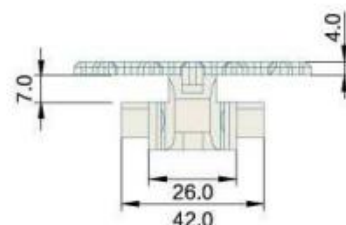
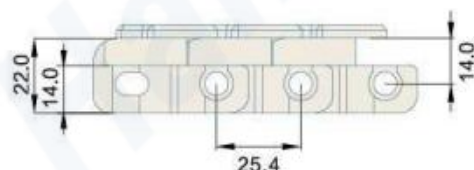
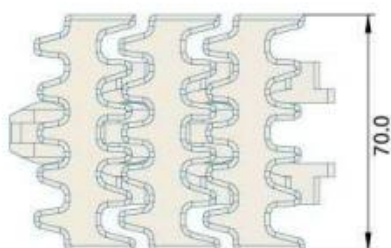

型号 Type No.	宽度 Width (mm)	节距 Pitch (mm)	重量 Weight (Kg/m)	转弯半径 Radius (mm)	负载 Working Capacity (N)
Har216618	70.0	25.4	1.30	200	2100

链轮 Sprocket	护栏 Guide	弯轨 Guide Rails	其余配件 Component
S67	R01-R42	—	C01-C57

Har216628 Series FLEXIBLE CHAINS

FLEXIBLE CHAINS 216628
P=25.4mm, T=22mm
PIN:Stainless steel

节距 Pitch	链板材质 Material	颜色 Color
25.4mm	POM	白色/White

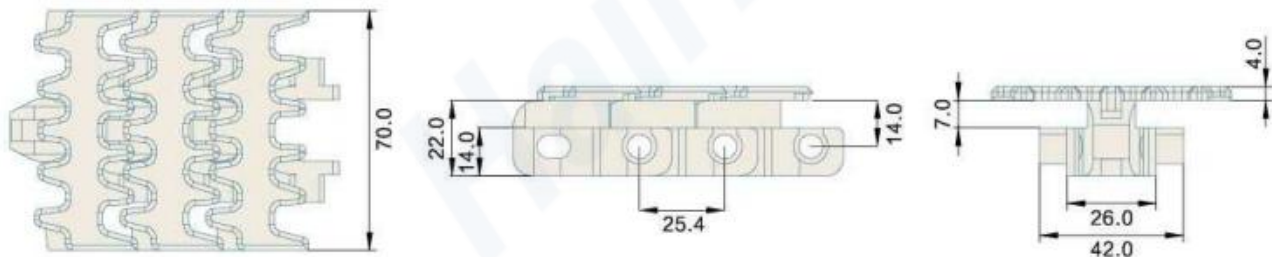

型号 Type No.	宽度 Width (mm)	节距 Pitch (mm)	重量 Weight (Kg/m)	转弯半径 Radius (mm)	负载 Working Capacity (N)
Har216628	70.0	25.4	1.30	200	2100

链轮 Sprocket	护栏 Guide	弯轨 Guide Rails	其余配件 Component
S67	R01-R42	—	C01-C57

Har1705H Series FLEXIBLE CHAINS

FLEXIBLE CHAINS 1705H
P=70.0mm, T=45.0mm
PIN:Stainless steel



节距 Pitch	链板材质 Material	颜色 Color
70.0mm	POM	蓝色/Blue

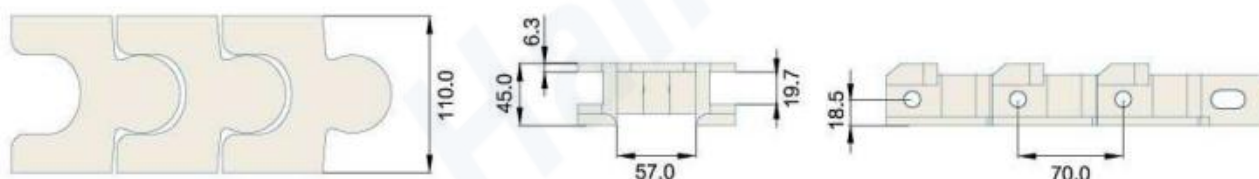

型号 Type No.	宽度 Width (mm)	节距 Pitch (mm)	重量 Weight (Kg/m)	转弯半径 Radius (mm)	负载 Working Capacity (N)
Har1705H	110.0	70.0	4.3	300	11000

链轮 Sprocket	护栏 Guide	弯轨 Guide Rails	其余配件 Component
—	R01-R42	—	C01-C57

Har1775 Series FLEXIBLE CHAINS

FLEXIBLE CHAINS 1775
P=25.4mm, T=25.5mm
PIN:Stainless steel

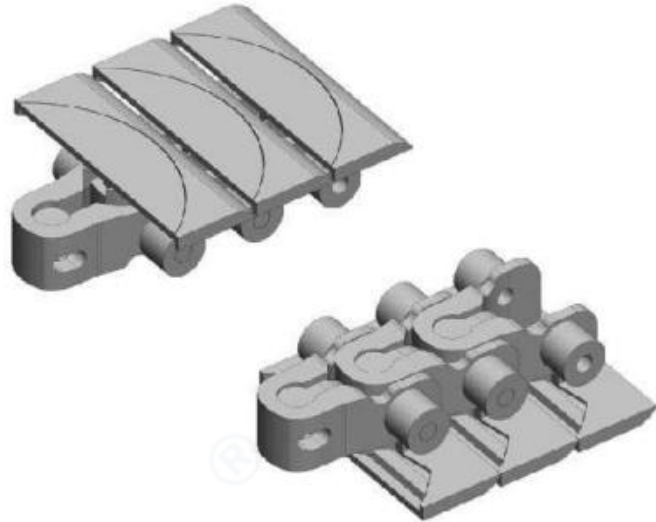

节距 Pitch	链板材质 Material	颜色 Color
25.4mm	POM	白色/White

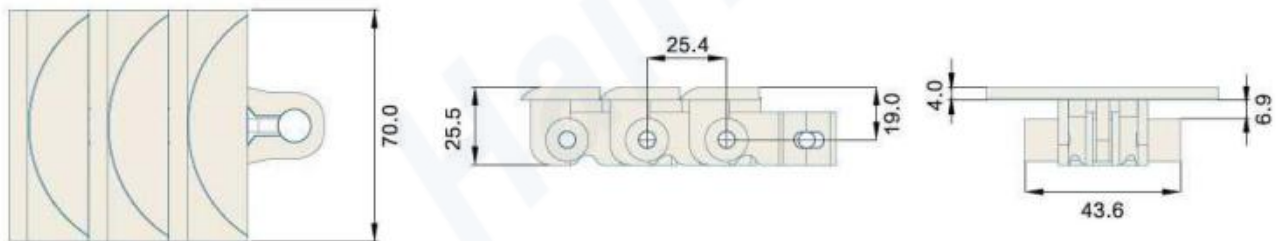

型号 Type No.	宽度 Width (mm)	节距 Pitch (mm)	重量 Weight (Kg/m)	转弯半径 Radius (mm)	负载 Working Capacity (N)
Har1775	70.0	25.4	1.12	150	2500

链轮 Sprocket	护栏 Guide	弯轨 Guide Rails	其余配件 Component
S09	R01-R42	—	C01-C57

Har1785 Series FLEXIBLE CHAINS

FLEXIBLE CHAINS 1785
P=47.75mm, T=8.5mm
PIN:Stainless steel

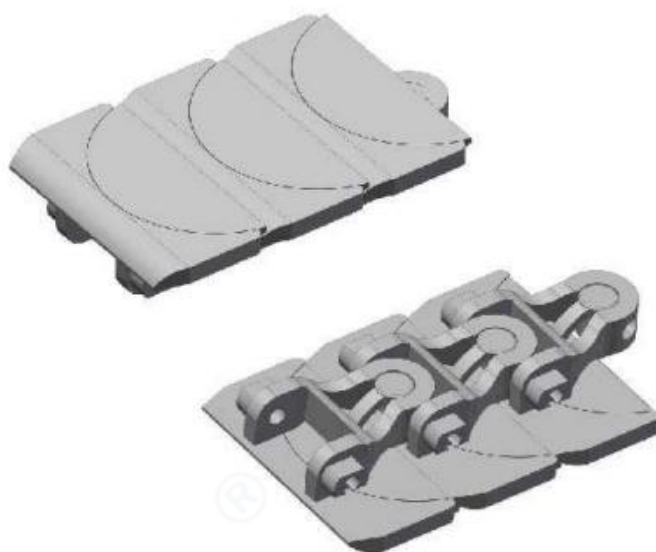

节距 Pitch	链板材质 Material	颜色 Color
47.75mm	POM	白色/White

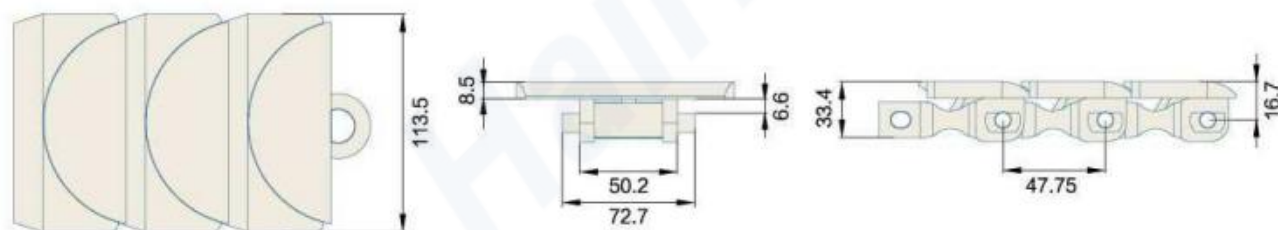

型号 Type No.	宽度 Width (mm)	节距 Pitch (mm)	重量 Weight (Kg/m)	转弯半径 Radius (mm)	负载 Working Capacity (N)
Har1785	113.5	47.75	2.36	200	3000

链轮 Sprocket	护栏 Guide	弯轨 Guide Rails	其余配件 Component
—	R01-R42	—	C01-C57

HarPT250A Series FLEXIBLE CHAINS

FLEXIBLE CHAINS PT250A
P=50.8mm, T=5mm
PIN:Stainless steel

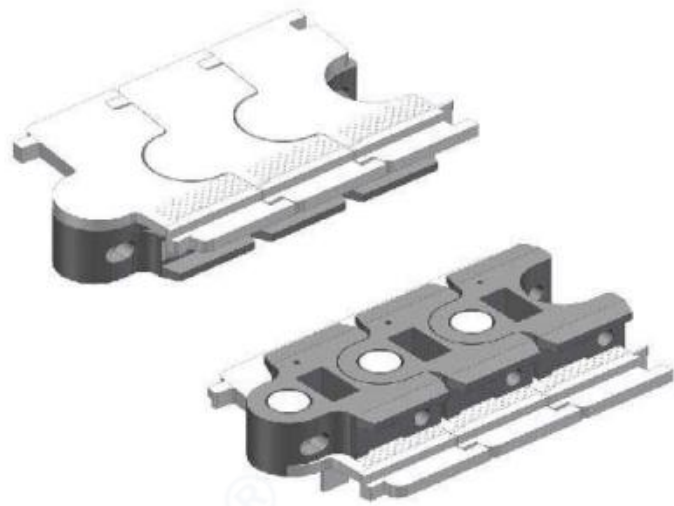

节距 Pitch	链板材质 Material	颜色 Color
50.8mm	POM	白色/White

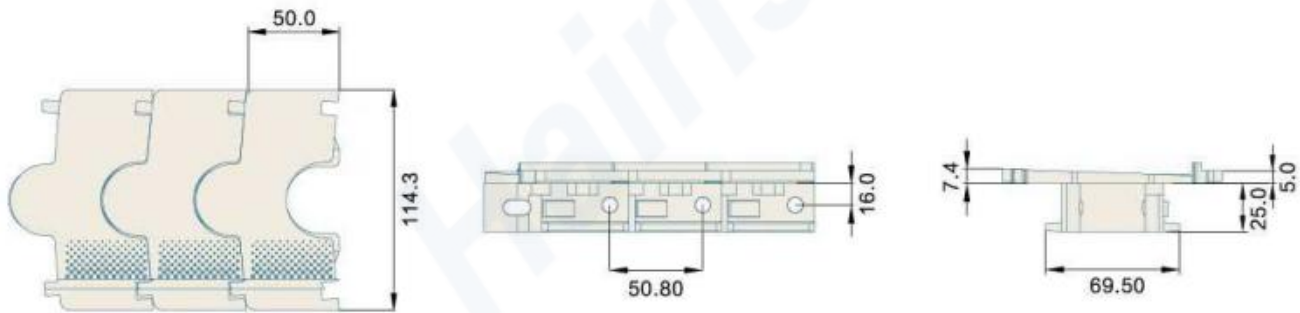

型号 Type No.	宽度 Width (mm)	节距 Pitch (mm)	重量 Weight (Kg/m)	转弯半径 Radius (mm)	负载 Working Capacity (N)
HarPT250A	114.3	50.8	2.3	610	7200

链轮 Sprocket	护栏 Guide	弯轨 Guide Rails	其余配件 Component
—	R01-R42	—	C01-C57

HarPT250B Series FLEXIBLE CHAINS

FLEXIBLE CHAINS PT250B
P=50.8mm, T=5mm
PIN:Stainless steel

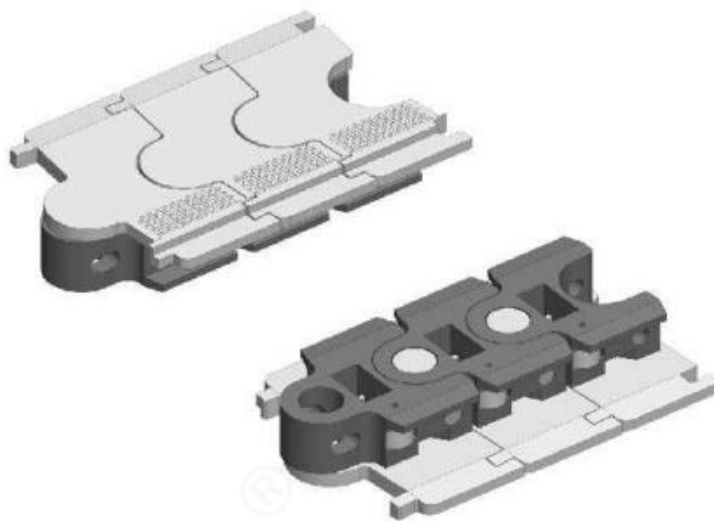

节距 Pitch	链板材质 Material	颜色 Color
50.8mm	POM	白色/White

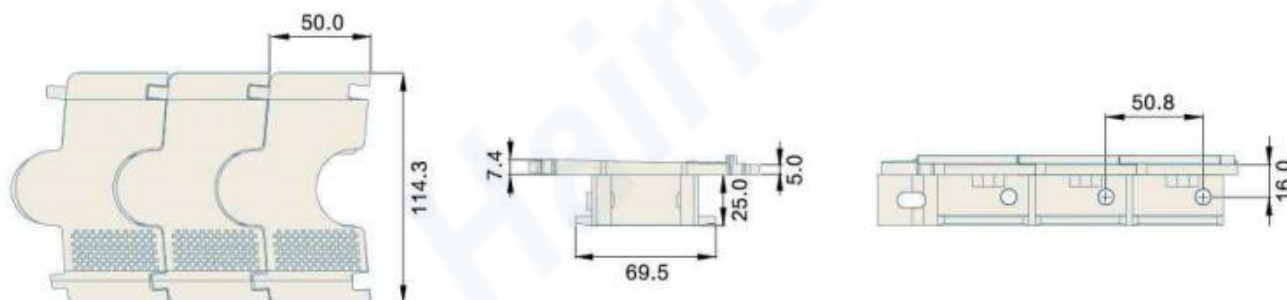

型号 Type No.	宽度 Width (mm)	节距 Pitch (mm)	重量 Weight (Kg/m)	转弯半径 Radius (mm)	负载 Working Capacity (N)
HarPT250B	114.3	50.8	2.3	610	7200

链轮 Sprocket	护栏 Guide	弯轨 Guide Rails	其余配件 Component
—	R01-R42	—	C01-C57

HarPT280 Series FLEXIBLE CHAINS

FLEXIBLE CHAINS PT280
P=50mm, T=24mm
PIN:Stainless steel



节距 Pitch	链板材质 Material	颜色 Color
50mm	POM	棕色/Brown

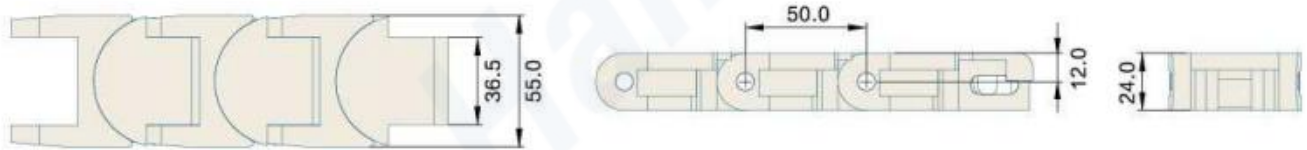

型号 Type No.	宽度 Width (mm)	节距 Pitch (mm)	重量 Weight (Kg/m)	转弯半径 Radius (mm)	负载 Working Capacity (N)
HarPT280	55.0	50.0	1.8	150	2670

链轮 Sprocket	护栏 Guide	弯轨 Guide Rails	其余配件 Component
S67	R01-R42	—	C01-C57

Har2300 Series FLEXIBLE CHAINS

FLEXIBLE CHAINS 2300
P=38.1mm, T=25.5mm
PIN:Stainless steel

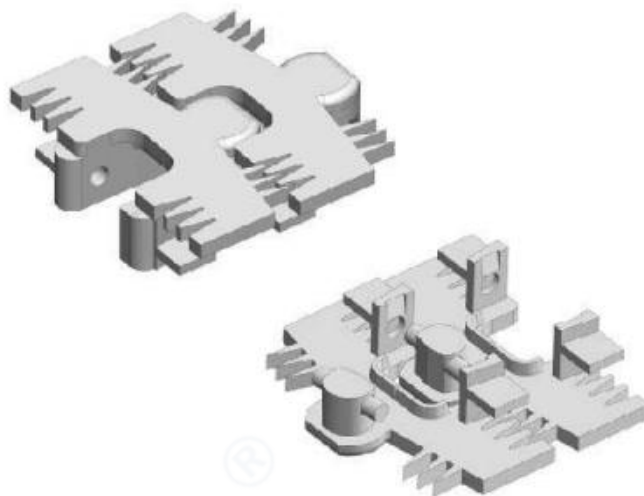

节距 Pitch	链板材质 Material	颜色 Color
38.1mm	POM	白色/White

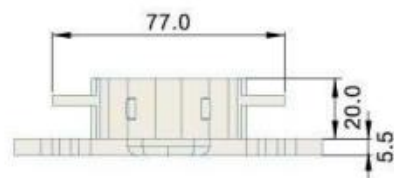
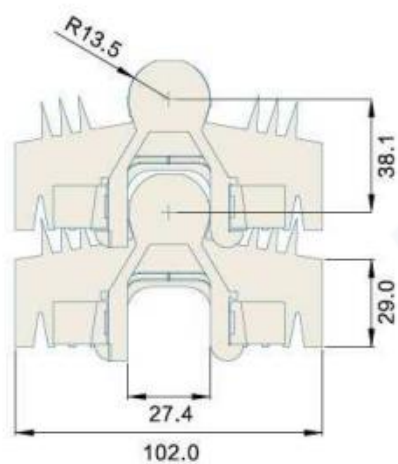

型号 Type No.	宽度 Width (mm)	节距 Pitch (mm)	重量 Weight (Kg/m)	转弯半径 Radius (mm)	负载 Working Capacity (N)
Har2300	102.0	38.1	1.60	170	2100

链轮 Sprocket	护栏 Guide	弯轨 Guide Rails	其余配件 Component
S45	R01-R42	—	C01-C57

Har2310 Series FLEXIBLE CHAINS

FLEXIBLE CHAINS 2310
P=38.1mm, T=4.8mm
PIN:Stainless steel

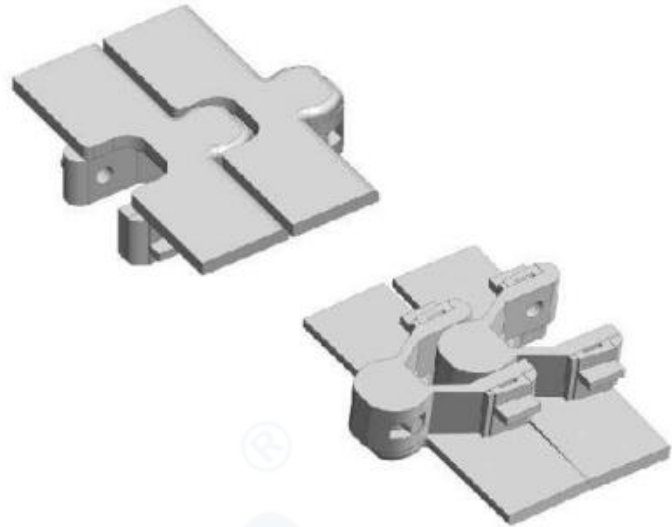

节距 Pitch	链板材质 Material	颜色 Color
38.1mm	POM	白色/White

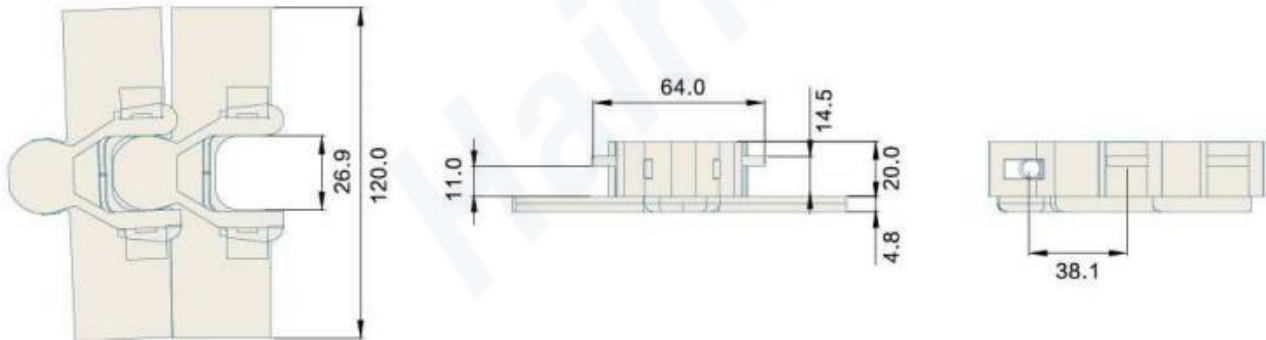

型号 Type No.	宽度 Width (mm)	节距 Pitch (mm)	重量 Weight (Kg/m)	转弯半径 Radius (mm)	负载 Working Capacity (N)
Har2310-K475	120.0	38.1	1.8	200	2100

链轮 Sprocket	护栏 Guide	弯轨 Guide Rails	其余配件 Component
S45	R01-R42	—	C01-C57

Har2100 Series FLEXIBLE CHAINS

FLEXIBLE CHAINS 2100
P=34.8mm, T=24.6mm
PIN:Stainless steel

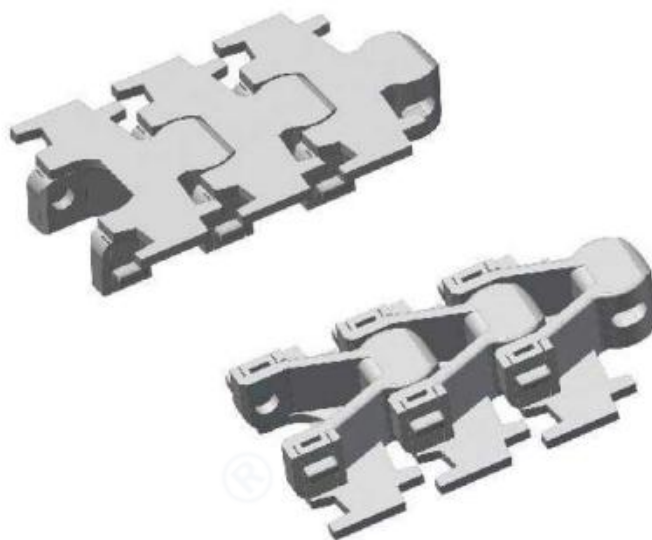

节距 Pitch	链板材质 Material	颜色 Color
34.8mm	POM	白色/White

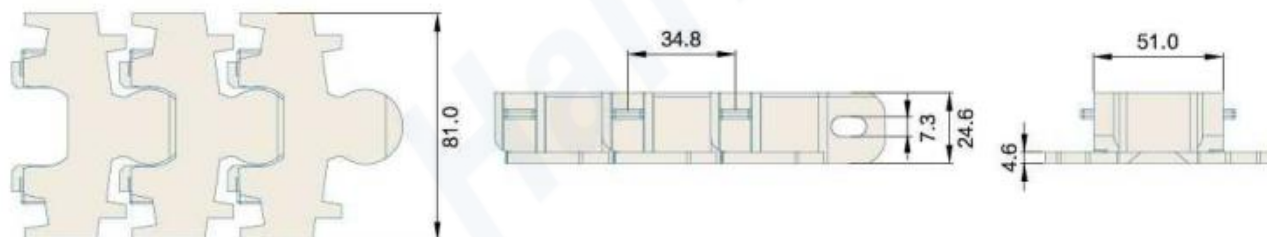

型号 Type No.	宽度 Width (mm)	节距 Pitch (mm)	重量 Weight (Kg/m)	转弯半径 Radius (mm)	负载 Working Capacity (N)
Har2100	81.0	34.8	1.35	150	2100

链轮 Sprocket	护栏 Guide	弯轨 Guide Rails	其余配件 Component
S45	R01-R42	—	C01-C57

Har2000 Series FLEXIBLE CHAINS

FLEXIBLE CHAINS 2000
P=38.1mm, T=25mm
PIN:Stainless steel

节距 Pitch	链板材质 Material	颜色 Color
38.1mm	POM	白色/White

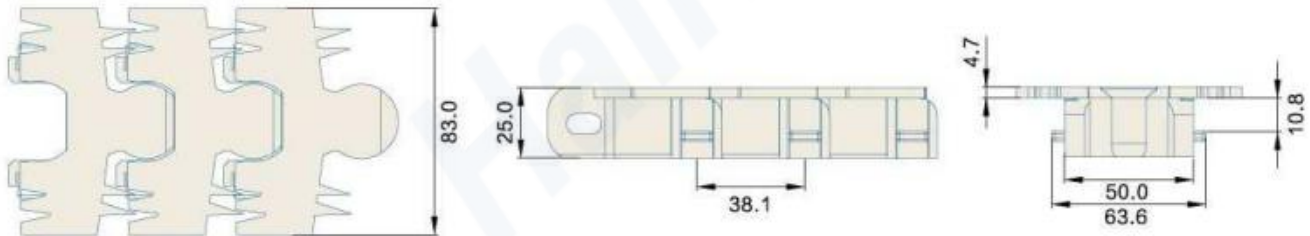
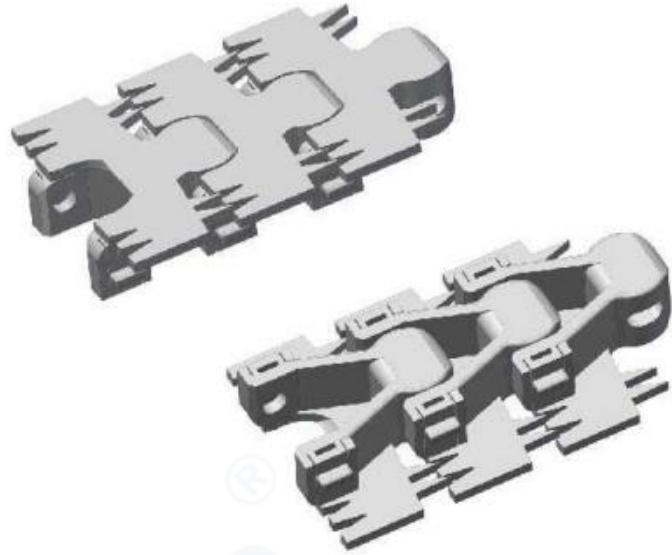

型号 Type No.	宽度 Width (mm)	节距 Pitch (mm)	重量 Weight (Kg/m)	转弯半径 Radius (mm)	负载 Working Capacity (N)
Har2000	83.0	38.1	1.35	150	2100

链轮 Sprocket	护栏 Guide	弯轨 Guide Rails	其余配件 Component
S37	R01-R42	—	C01-C57

Har2480PMO Series FLEXIBLE CHAINS

FLEXIBLE CHAINS 2480PMO
P=38.1mm, T=25mm
PIN:Stainless steel

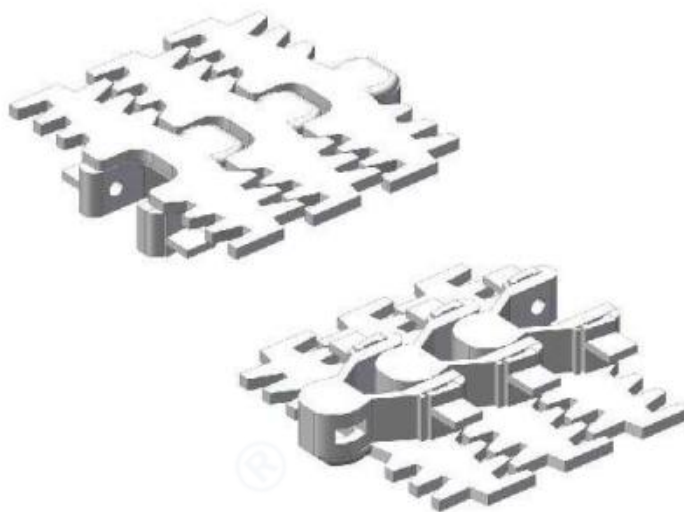

节距 Pitch	链板材质 Material	颜色 Color
38.1mm	POM	白色/White

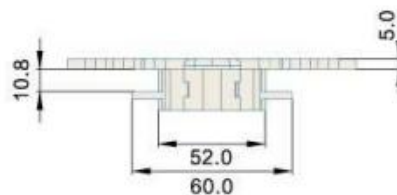
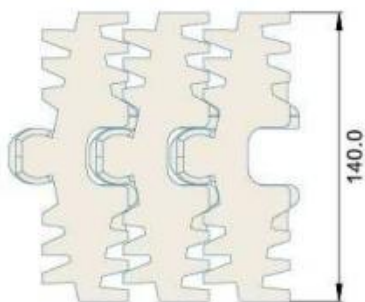

型号 Type No.	宽度 Width (mm)	节距 Pitch (mm)	重量 Weight (Kg/m)	转弯半径 Radius (mm)	负载 Working Capacity (N)
Har2480PMO-K551	140	38.1	2.1	200	2100

链轮 Sprocket	护栏 Guide	弯轨 Guide Rails	其余配件 Component
S45	R01-R42	—	C01-C57

Har2480PMO Series Rubber Cover FLEXIBLE CHAINS

FLEXIBLE CHAINS 2480PMO
P=38.1mm, T=25mm
PIN:Stainless steel

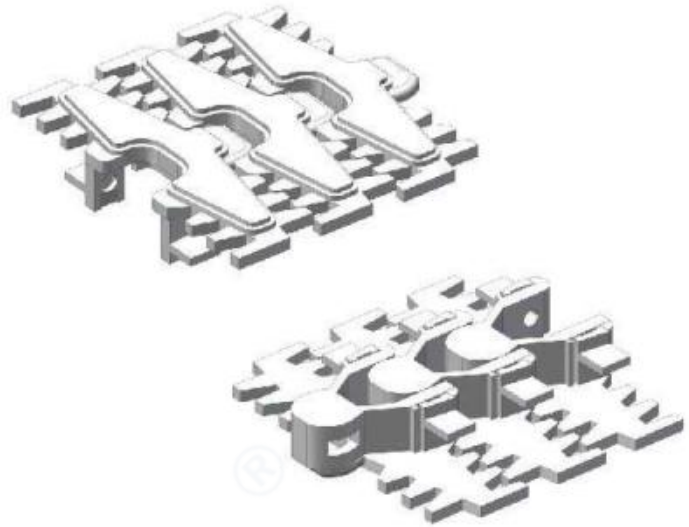

节距 Pitch	链板材质 Material	颜色 Color
38.1mm	POM	白色/White

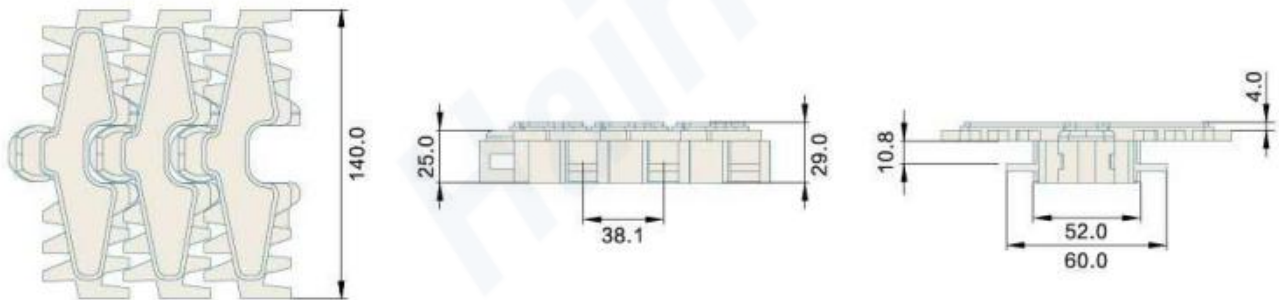

型号 Type No.	宽度 Width (mm)	节距 Pitch (mm)	重量 Weight (Kg/m)	转弯半径 Radius (mm)	负载 Working Capacity (N)
Har2480PMO-RC-K551	140	38.1	2.9	200	2100

链轮 Sprocket	护栏 Guide	弯轨 Guide Rails	其余配件 Component
S45	R01-R42	—	C01-C57

Har2480PMZ Series FLEXIBLE CHAINS

FLEXIBLE CHAINS 2480PMZ
P=25.5mm, T=3mm
PIN:Stainless steel

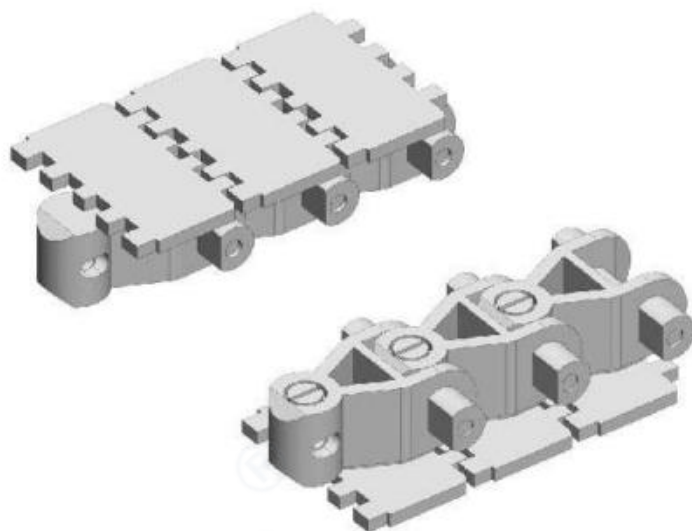

节距 Pitch	链板材质 Material	颜色 Color
25.5mm	POM	白色/White

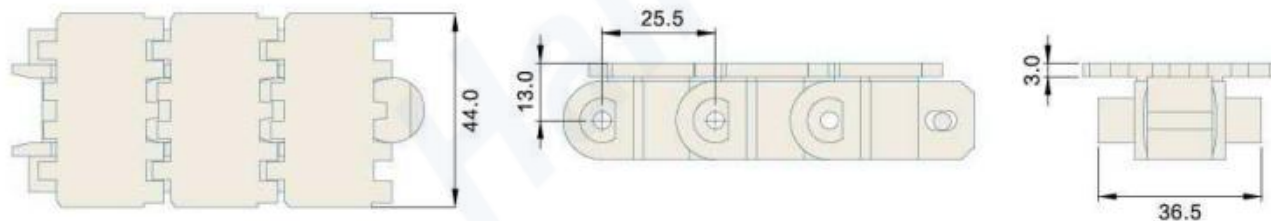

型号 Type No.	宽度 Width (mm)	节距 Pitch (mm)	重量 Weight (Kg/m)	转弯半径 Radius (mm)	负载 Working Capacity (N)
Har2480PMZ-K173	44.0	25.5	0.6	160	2100

链轮 Sprocket	护栏 Guide	弯轨 Guide Rails	其余配件 Component
—	R01-R42	—	C01-C57

Har2350PW Series FLEXIBLE CHAINS

FLEXIBLE CHAINS 2350PW
P=25.4mm, T=22.5mm
PIN:Stainless steel

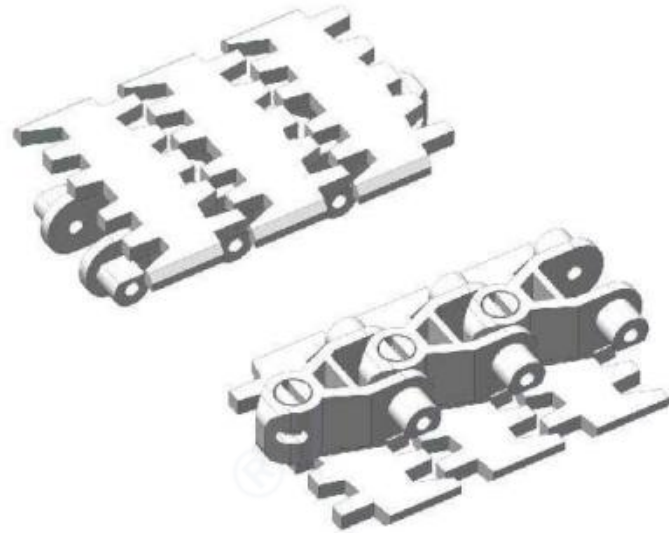

节距 Pitch	链板材质 Material	颜色 Color
25.4mm	POM	白色/White

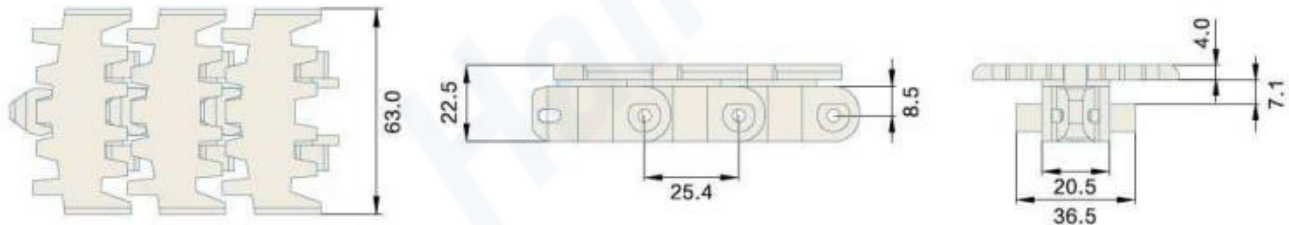

型号 Type No.	宽度 Width (mm)	节距 Pitch (mm)	重量 Weight (Kg/m)	转弯半径 Radius (mm)	负载 Working Capacity (N)
Har2350PW-K248	63.0	25.4	0.8	150	2100

链轮 Sprocket	护栏 Guide	弯轨 Guide Rails	其余配件 Component
S41-S43	R01-R42	—	C01-C57

Har2350PW Series FLEXIBLE CHAINS

FLEXIBLE CHAINS 2350PW
P=33.5mm, T=25.2mm
PIN:Stainless steel

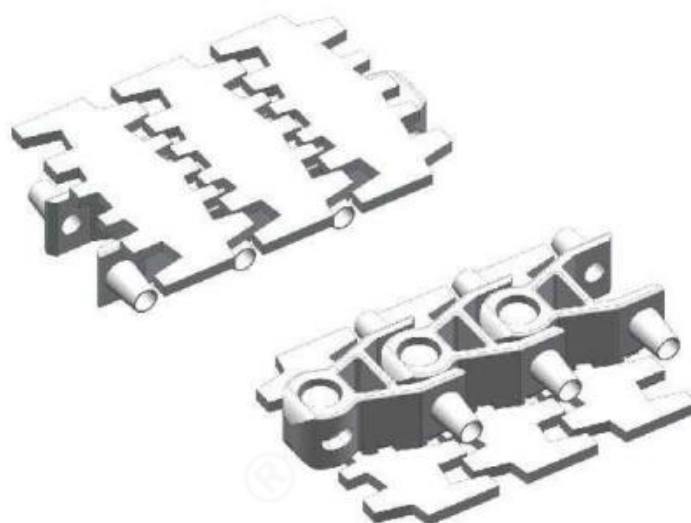

节距 Pitch	链板材质 Material	颜色 Color
33.5mm	POM	白色/White

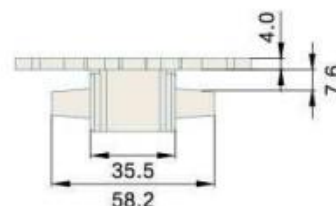
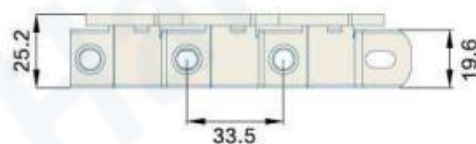
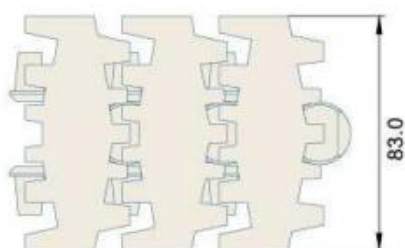

型号 Type No.	宽度 Width (mm)	节距 Pitch (mm)	重量 Weight (Kg/m)	转弯半径 Radius (mm)	负载 Working Capacity (N)
Har2350PW-K327	83.0	33.5	1.2	160	2100

链轮 Sprocket	护栏 Guide	弯轨 Guide Rails	其余配件 Component
S41-S43	R01-R42	—	C01-C57

Har2350PW Series FLEXIBLE CHAINS

FLEXIBLE CHAINS 2350PW
P=35.5mm, T=26mm
PIN:Stainless steel

节距 Pitch	链板材质 Material	颜色 Color
35.5mm	POM	白色/White

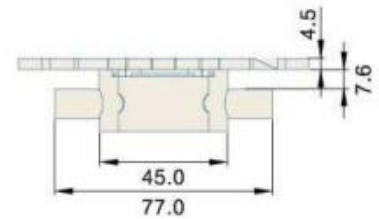
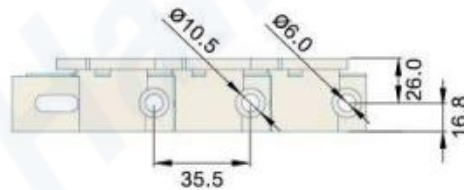
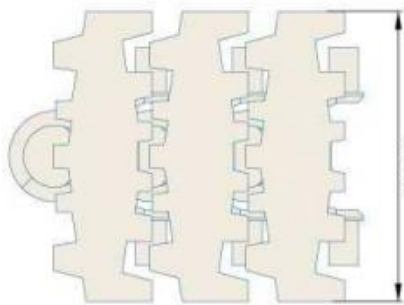
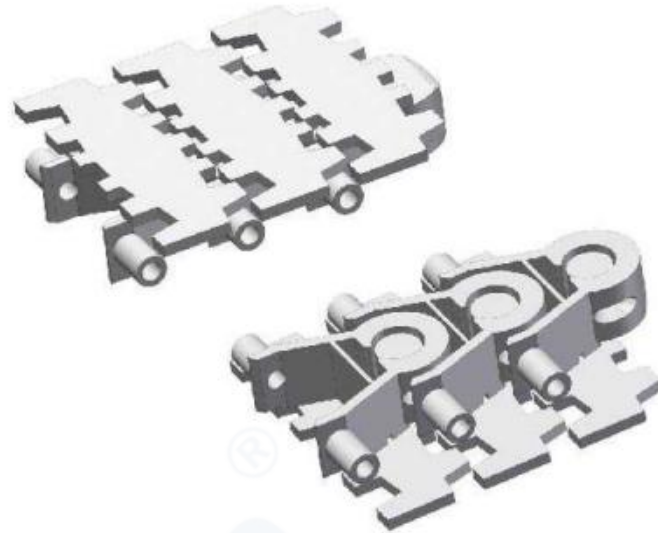

型号 Type No.	宽度 Width (mm)	节距 Pitch (mm)	重量 Weight (Kg/m)	转弯半径 Radius (mm)	负载 Working Capacity (N)
Har2350PW-K406	103.0	35.5	1.6	170	2100

链轮 Sprocket	护栏 Guide	弯轨 Guide Rails	其余配件 Component
S41-S43	R01-R42	—	C01-C57

Har2350PW Series FLEXIBLE CHAINS

FLEXIBLE CHAINS 2350PW
P=35.5mm, T=4.5mm
PIN:Stainless steel

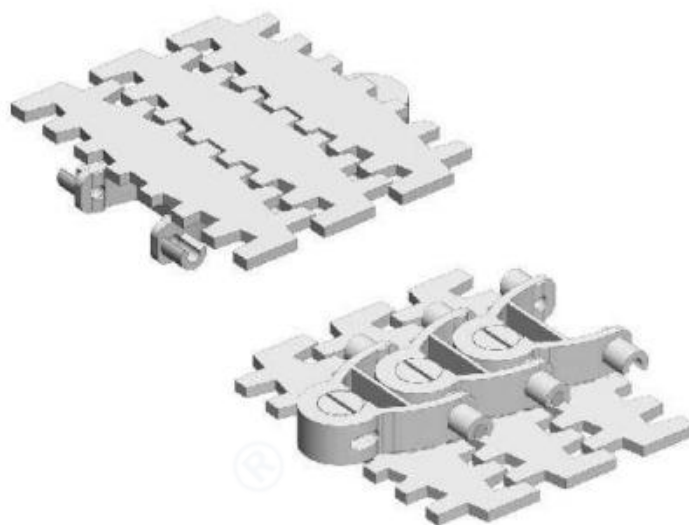

节距 Pitch	链板材质 Material	颜色 Color
35.5mm	POM	白色/White

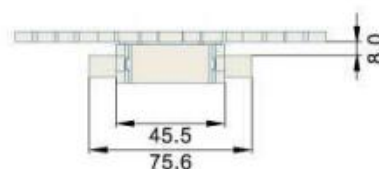
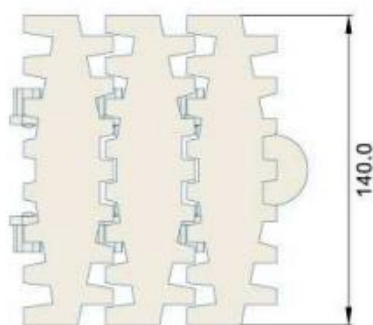

型号 Type No.	宽度 Width (mm)	节距 Pitch (mm)	重量 Weight (Kg/m)	转弯半径 Radius (mm)	负载 Working Capacity (N)
Har2350PW-K551	140	35.5	1.95	200	2100

链轮 Sprocket	护栏 Guide	弯轨 Guide Rails	其余配件 Component
S41-S43	R01-R42	—	C01-C57

Har2350PW Series FLEXIBLE CHAINS

FLEXIBLE CHAINS 2350PW
P=33.5mm, T=28.5mm
PIN:Stainless steel

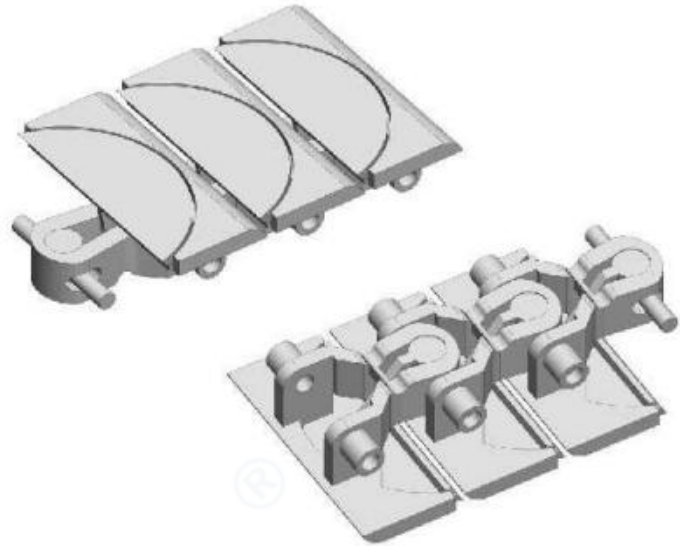

节距 Pitch	链板材质 Material	颜色 Color
33.5mm	POM	白色/White

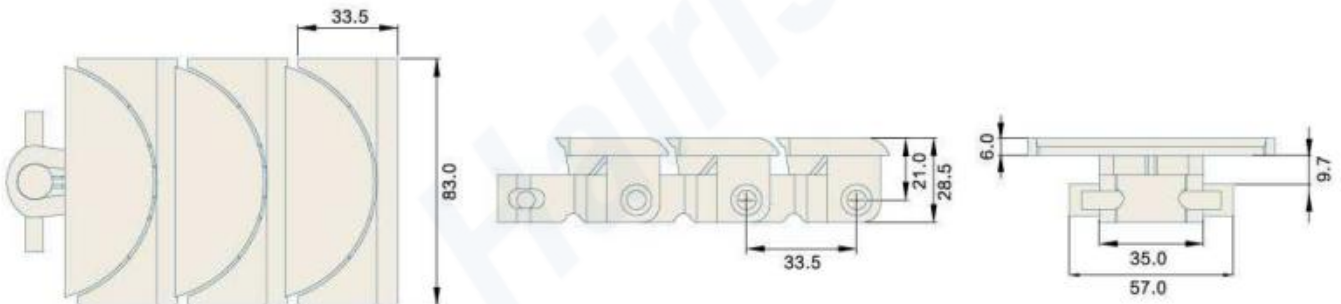

型号 Type No.	宽度 Width (mm)	节距 Pitch (mm)	重量 Weight (Kg/m)	转弯半径 Radius (mm)	负载 Working Capacity (N)
Har2350PW-83	83.0	33.5	1.4	150	2500
Har2350PW-103	103.0	41.9	1.75	170	2500

链轮 Sprocket	护栏 Guide	弯轨 Guide Rails	其余配件 Component
S41-S44	R01-R42	—	C01-C57

Har2350TM Series

FLEXIBLE CHAINS

FLEXIBLE CHAINS 2350TM

P=35.5mm, T=27mm

PIN:Stainless steel

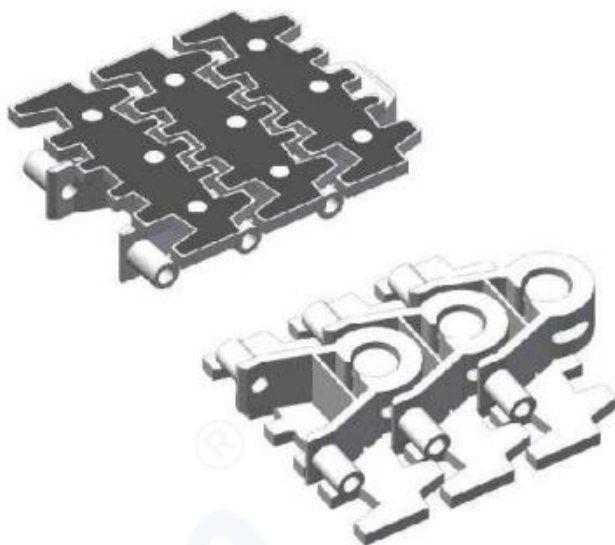

节距 Pitch	链板材质 Material	颜色 Color
25.4mm	POM	白色/White
33.5mm	POM	白色/White
35.5mm	POM	白色/White

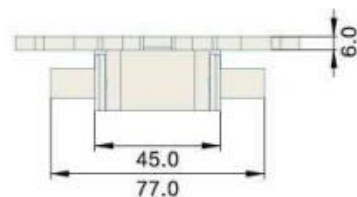
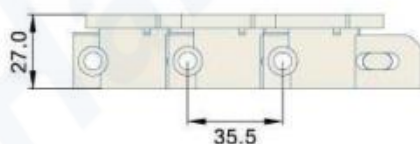
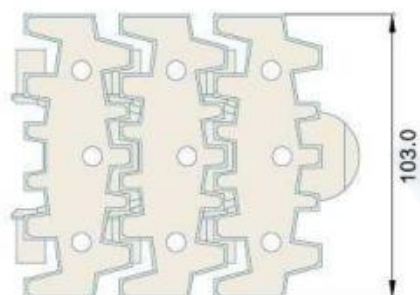

型号 Type No.	宽度 Width (mm)	节距 Pitch (mm)	重量 Weight (Kg/m)	转弯半径 Radius (mm)	负载 Working Capacity (N)
Har2350TM-K248	63.0	25.4	2.10	150	2100
Har2350TM-K327	83.0	33.5	2.40	160	2100
Har2350TM-K406	103.0	35.5	2.80	170	2100

链轮 Sprocket	护栏 Guide	弯轨 Guide Rails	其余配件 Component
S41-S43	R01-R42	—	C01-C57

Har2350PW-VT Series FLEXIBLE CHAINS

FLEXIBLE CHAINS 2350PW-VT
P=33.5mm, T=51mm
PIN:Stainless steel

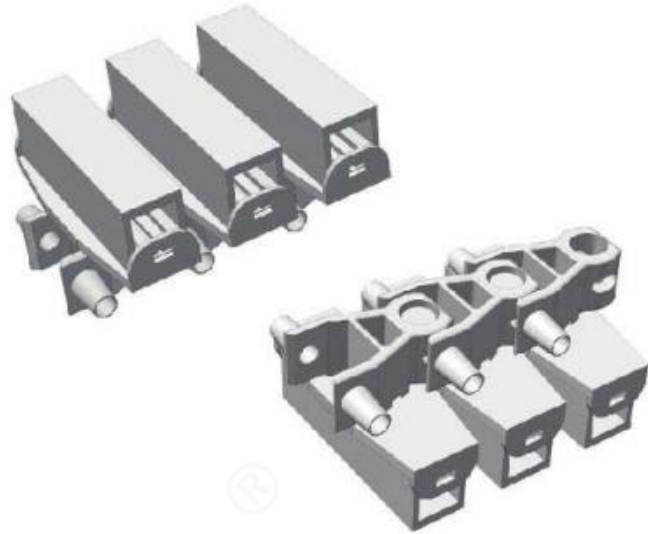

节距 Pitch	链板材质 Material	颜色 Color
33.5mm	POM	白色/White

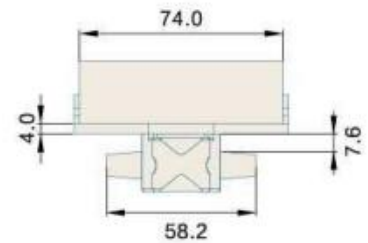
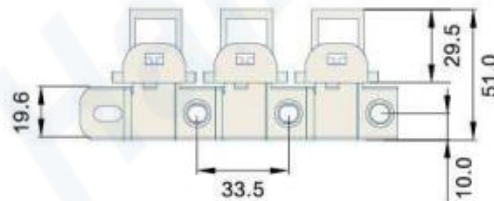
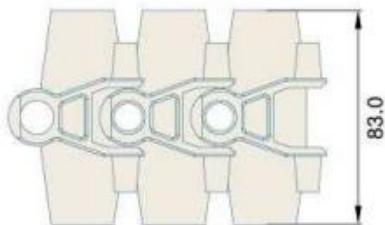

型号 Type No.	宽度 Width (mm)	节距 Pitch (mm)	重量 Weight (Kg/m)	转弯半径 Radius (mm)	负载 Working Capacity (N)
Har2350PW-VT-K327	83.0	33.5	2.52	160	2100

链轮 Sprocket	护栏 Guide	弯轨 Guide Rails	其余配件 Component
S41-S43	R01-R42	—	C01-C57

Har2350PW-VTR Series

FLEXIBLE CHAINS

FLEXIBLE CHAINS 2350PW-VTR

P=25.4mm, T=46.5mm

PIN:Stainless steel

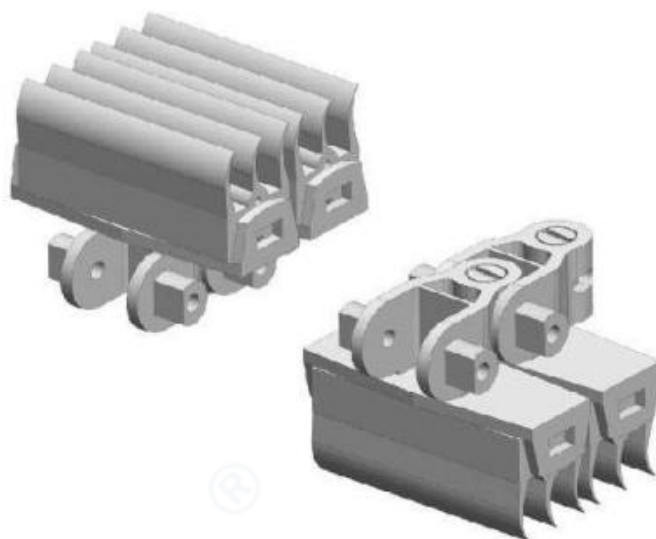

节距 Pitch	链板材质 Material	颜色 Color
25.4mm	POM	白色/White

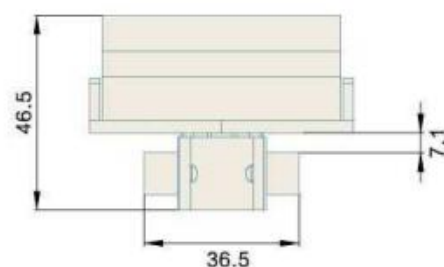
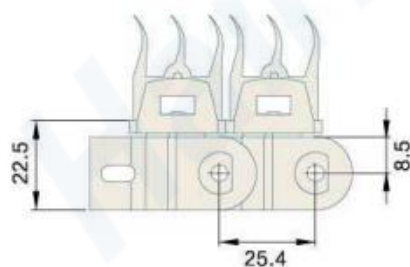
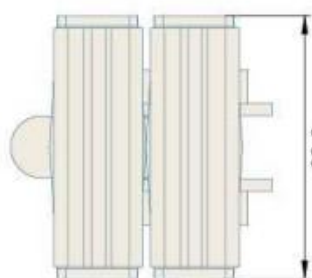

型号 Type No.	宽度 Width (mm)	节距 Pitch (mm)	重量 Weight (Kg/m)	转弯半径 Radius (mm)	负载 Working Capacity (N)
Har2350PW-VTR-K248	63.0	25.4	1.90	150	2100

链轮 Sprocket	护栏 Guide	弯轨 Guide Rails	其余配件 Component
S41-S43	R01-R42	—	C01-C57

Har2350PW-VTR Series FLEXIBLE CHAINS

FLEXIBLE CHAINS 2350PW-VTR
P=33.5mm, T=53.5mm
PIN:Stainless steel

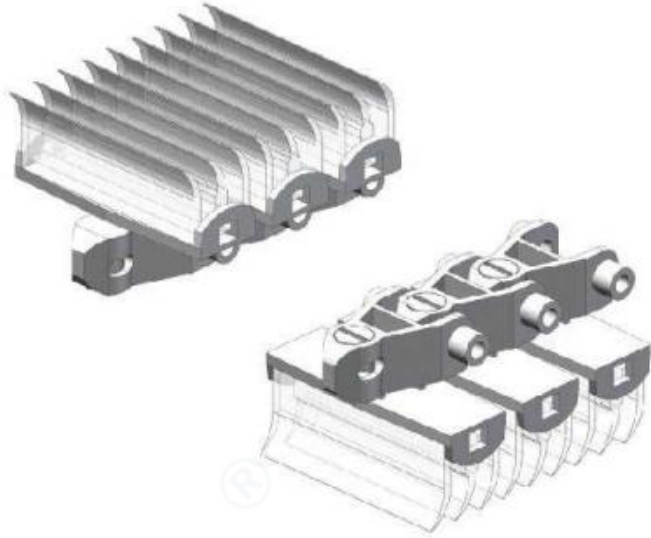

节距 Pitch	链板材质 Material	颜色 Color
33.5mm	POM	白色/White

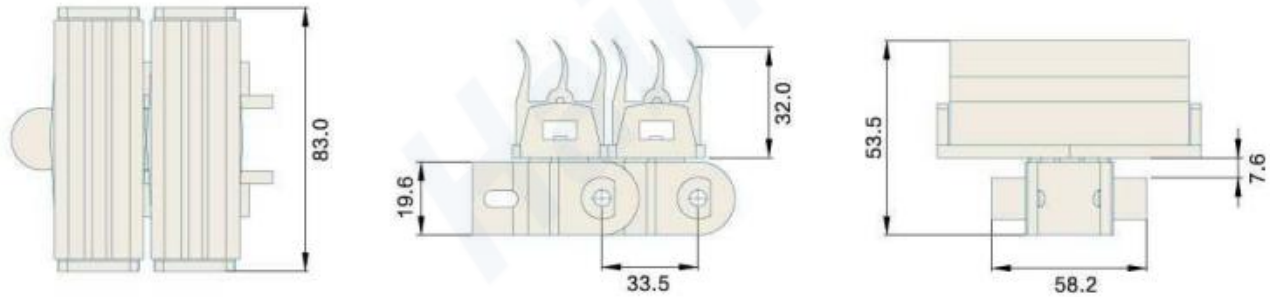

型号 Type No.	宽度 Width (mm)	节距 Pitch (mm)	重量 Weight (Kg/m)	转弯半径 Radius (mm)	负载 Working Capacity (N)
Har2350PW-VTR-K327	83.0	33.5	2.52	160	2100

链轮 Sprocket	护栏 Guide	弯轨 Guide Rails	其余配件 Component
S41-S43	R01-R42	—	C01-C57

Har2350VTC Series FLEXIBLE CHAINS

FLEXIBLE CHAINS 2350VTC Series
P=33.5mm, T=50mm
PIN:Stainless steel

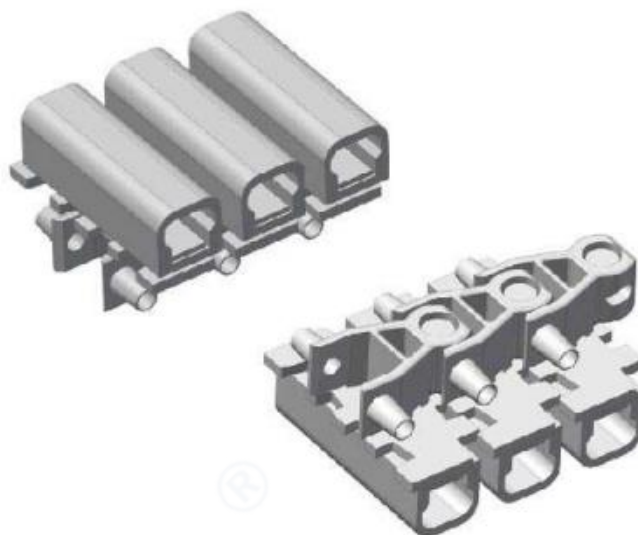

节距 Pitch	链板材质 Material	颜色 Color
33.5mm	POM	白色/White

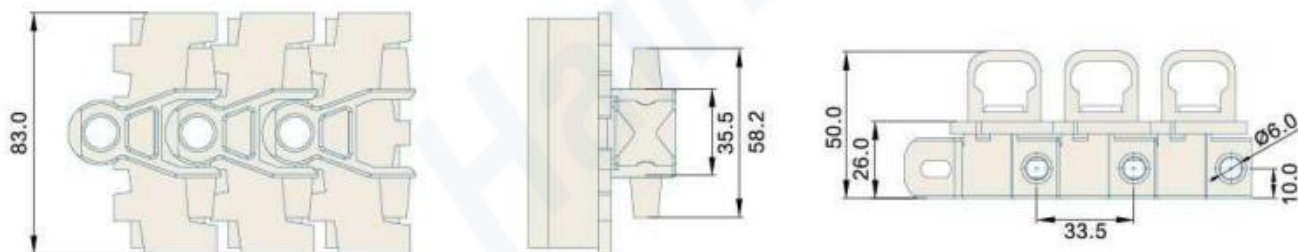

型号 Type No.	宽度 Width (mm)	节距 Pitch (mm)	重量 Weight (Kg/m)	转弯半径 Radius (mm)	负载 Working Capacity (N)
Har2350VTC-K327	83.0	33.5	2.52	160	2100

链轮 Sprocket	护栏 Guide	弯轨 Guide Rails	其余配件 Component
S41-S43	R01-R42	—	C01-C57

Har2350V Series FLEXIBLE CHAINS

FLEXIBLE CHAINS 2350V Series
P=25.4/33.5mm, T=30.7mm
PIN:Stainless steel

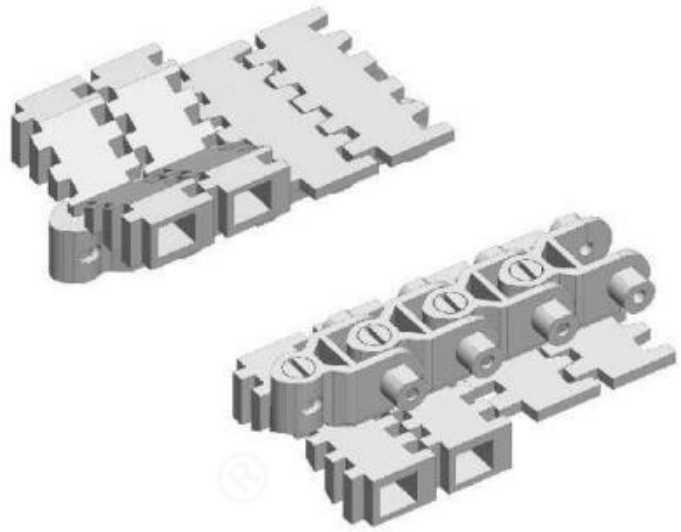

节距 Pitch	链板材质 Material	颜色 Color
25.4mm	POM	白色/White
33.5mm	POM	白色/White

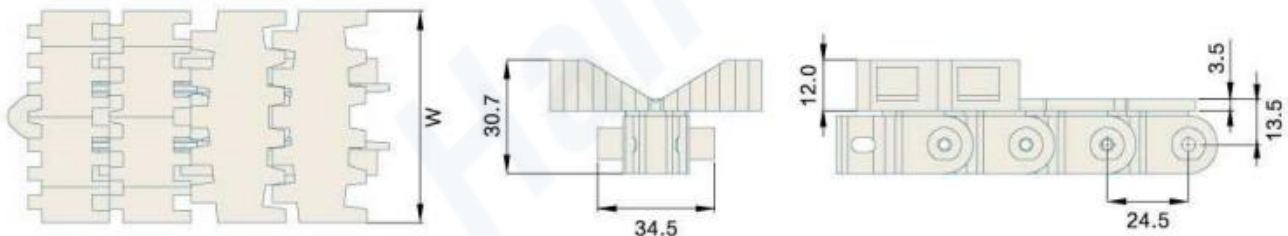

型号 Type No.	宽度 Width (mm)	节距 Pitch (mm)	重量 Weight (Kg/m)	转弯半径 Radius (mm)	负载 Working Capacity (N)
Har2350V-K248	63.0	25.4	1.90	150	2100
Har2350V-K327	83.0	33.5	2.38	160	2100

链轮 Sprocket	护栏 Guide	弯轨 Guide Rails	其余配件 Component
S41-S43	R01-R42	—	C01-C57

Har2480GZM Series FLEXIBLE CHAINS

FLEXIBLE CHAINS 2480GZM Series
P=33.5/35.5mm, T=37.5mm
PIN:Stainless steel

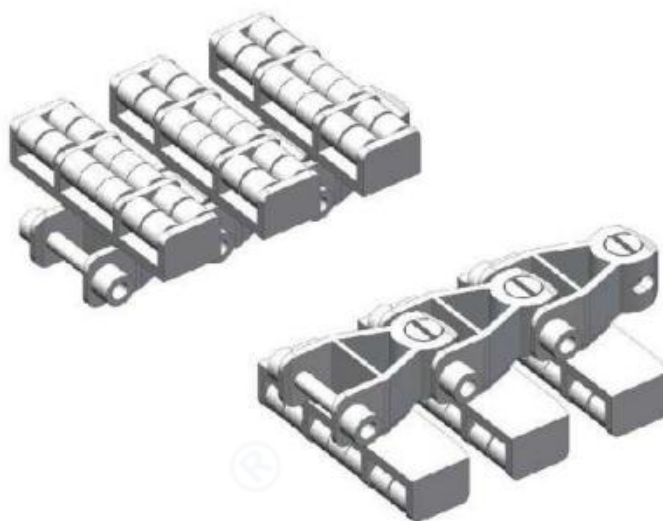

节距 Pitch	链板材质 Material	颜色 Color
33.5mm	POM	白色/White
35.5mm	POM	白色/White

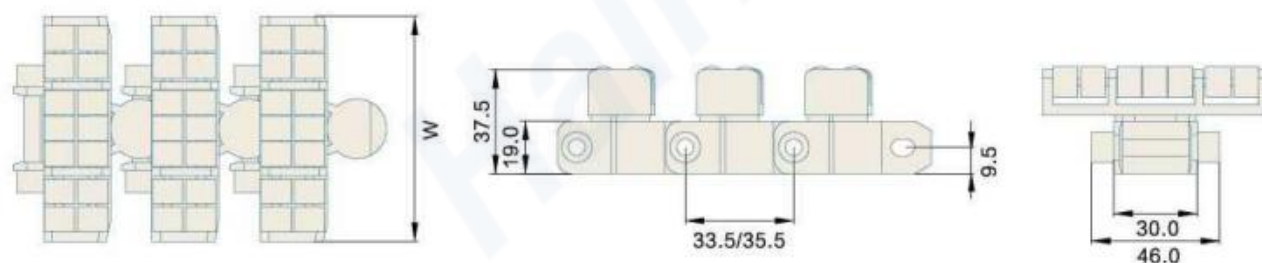

型号 Type No.	宽度 Width (mm)	节距 Pitch (mm)	重量 Weight (Kg/m)	转弯半径 Radius (mm)	负载 Working Capacity (N)
Har2480GZM-K327	83.0	33.5	1.8	160	2100
Har2480GZM-K406	103.0	35.5	2.1	170	2100

链轮 Sprocket	护栏 Guide	弯轨 Guide Rails	其余配件 Component
S41-S43	R01-R42	—	C01-C57

Har2840 Series FLEXIBLE CHAINS

FLEXIBLE CHAINS 2840 Series
P=25.4mm, T=22.5mm
PIN:Stainless steel

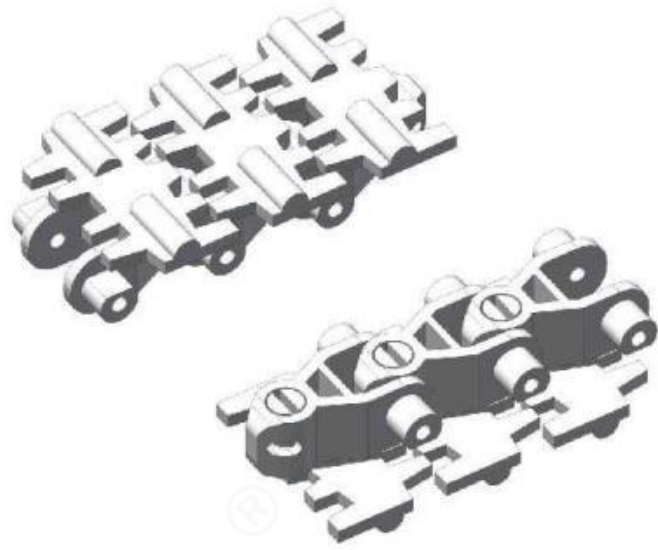

节距 Pitch	链板材质 Material	颜色 Color
25.4mm	POM	白色/White
33.5mm	POM	白色/White

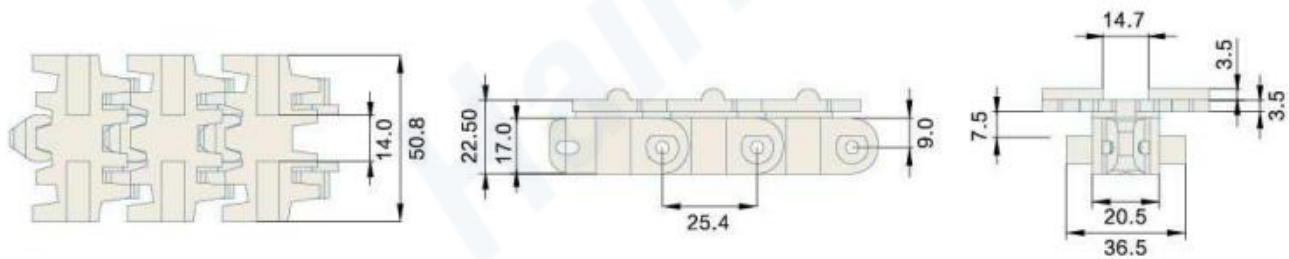

型号 Type No.	宽度 Width (mm)	节距 Pitch (mm)	重量 Weight (Kg/m)	转弯半径 Radius (mm)	负载 Working Capacity (N)
Har2840-K248	63.0	25.4	1.30	150	2100
Har2840-K327	83.0	33.5	1.75	160	2100

链轮 Sprocket	护栏 Guide	弯轨 Guide Rails	其余配件 Component
S50	R01-R42	—	C01-C57

Har2350DM/M/TM/PRR Series FLEXIBLE CHAINS

FLEXIBLE CHAINS DM/M/TM/PRR

P=25.4/33.5/35.5mm, PIN:Stainless steel
附件系列:

直挡板 Straight cleat height:48mm

弯挡板 Bending cleat height:48mm

三角挡板 Triangular Cleat Height:5-30mm

滚珠挡块 Roller cleat height:54mm



节距 Pitch	链板材质 Material	颜色 Color
25.4mm	POM	白色/White
33.5mm	POM	白色/White
35.5mm	POM	白色/White

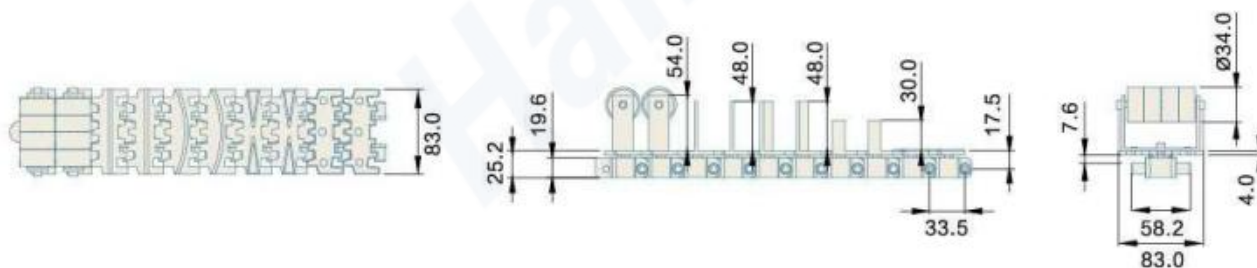

型号 Type No.	宽度 Width (mm)	节距 Pitch (mm)	重量 Weight (Kg/m)	转弯半径 Radius (mm)	负载 Working Capacity (N)
Har2350DM/M/TM/PRR-K248	63.0	25.4	2.10	150	2100
Har2350DM/M/TM/PRR-K327	83.0	33.5	2.40	160	2100
Har2350DM/M/TM/PRR-K406	103.0	35.5	2.80	170	2100

链轮 Sprocket	护栏 Guide	弯轨 Guide Rails	其余配件 Component
S41-S43	R01-R42	—	C01-C57

Har2350 Roller Top Series FLEXIBLE CHAINS

FLEXIBLE CHAINS 2350 Roller Top
P=33.5mm, T=4mm
PIN:Stainless steel

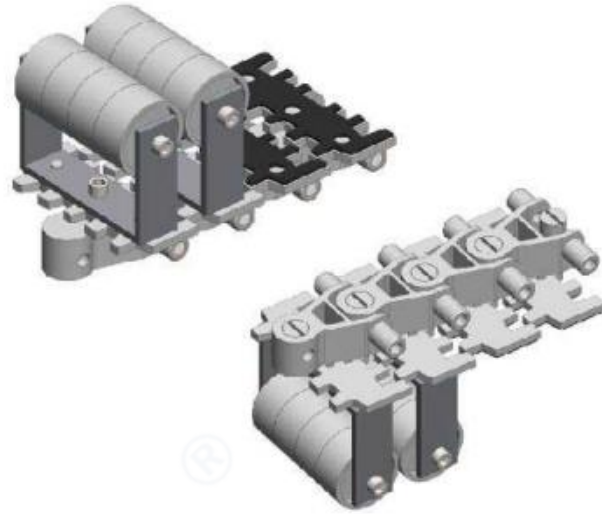

节距 Pitch	链板材质 Material	颜色 Color
25.4mm	POM	白色/White
33.5mm	POM	白色/White
35.5mm	POM	白色/White

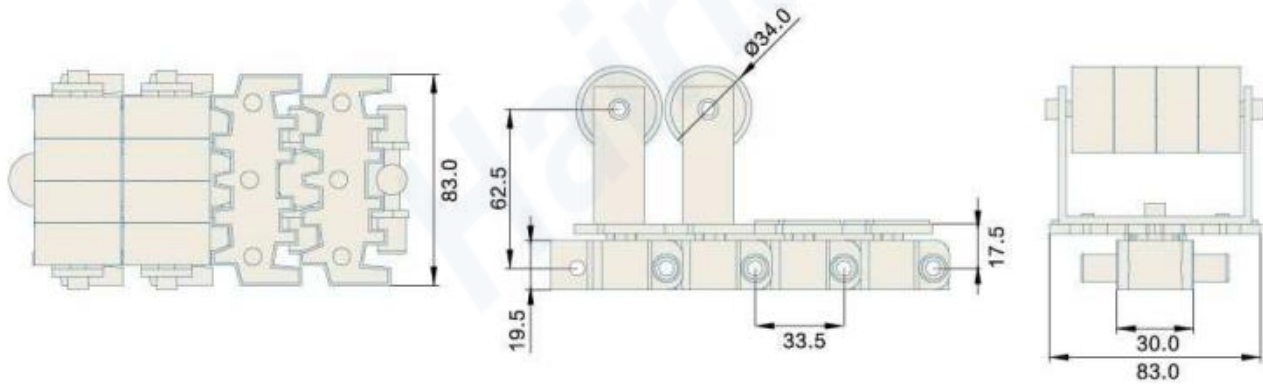

型号 Type No.	宽度 Width (mm)	节距 Pitch (mm)	重量 Weight (Kg/m)	转弯半径 Radius (mm)	负载 Working Capacity (N)
Har2350PRR-K248	63.0	25.4	1.50	150	2100
Har2350PRR-K327	83.0	33.5	2.00	160	2100
Har2350PRR-K406	103.0	35.5	2.70	170	2100

链轮 Sprocket	护栏 Guide	弯轨 Guide Rails	其余配件 Component
S41-S43	R01-R42	—	C01-C57

Har2350DM Series

FLEXIBLE CHAINS

FLEXIBLE CHAINS 2350DM

P=25.4/33.5/35.5mm, T=4mm

PIN:Stainless steel

三角挡板 Triangular Cleat Height: 5-30mm

钩脚挡板 Bending Cleat Height: 14mm

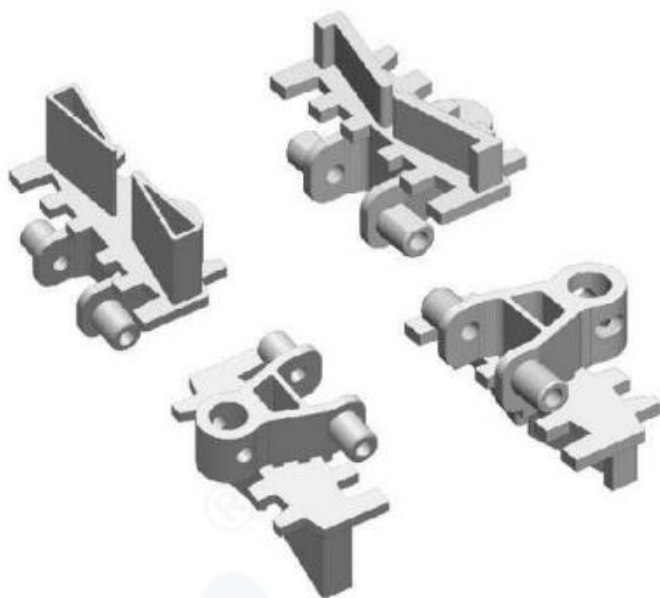

节距 Pitch	链板材质 Material	颜色 Color
25.4mm	POM	白色/White
33.5mm	POM	白色/White
35.5mm	POM	白色/White

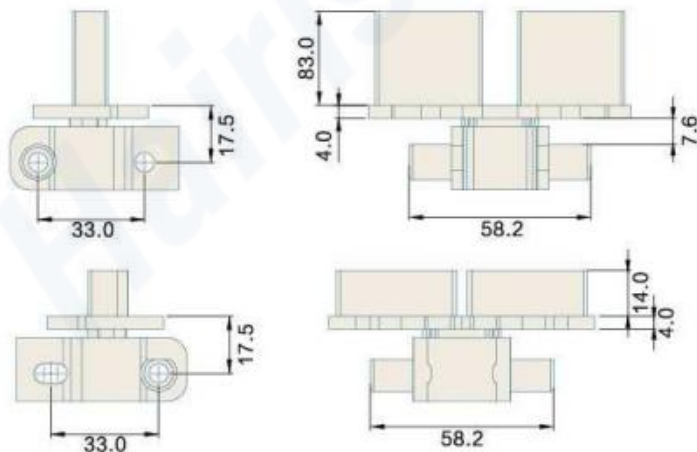
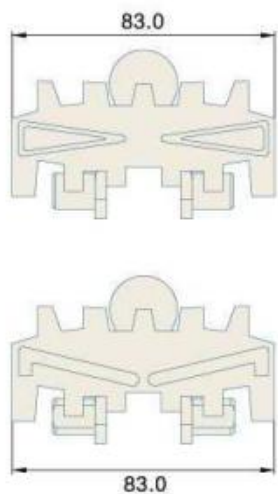

型号 Type No.	宽度 Width (mm)	节距 Pitch (mm)	重量 Weight (Kg/m)	转弯半径 Radius (mm)	负载 Working Capacity (N)
Har2350DM-K248	63.0	25.4	1.50	150	2100
Har2350DM-K327	83.0	33.5	2.00	160	2100
Har2350DM-K406	103.0	35.5	2.70	170	2100

链轮 Sprocket	护栏 Guide	弯轨 Guide Rails	其余配件 Component
S41-S43	R01-R42	—	C01-C57

Har2580 Series FLEXIBLE CHAINS

FLEXIBLE CHAINS 2580
P=33.5mm, T=29.4mm
PIN:Stainless steel



节距 Pitch	链板材质 Material	颜色 Color
33.5mm	POM	白色/White

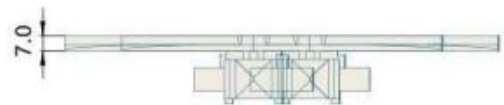
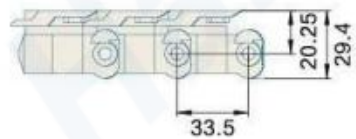
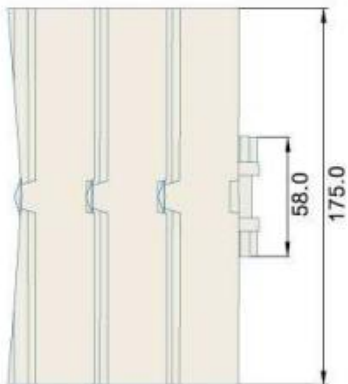

型号 Type No.	宽度 Width (mm)	节距 Pitch (mm)	重量 Weight (Kg/m)	转弯半径 Radius (mm)	负载 Working Capacity (N)
Har2580	175.0	33.5	1.53	500	1250

链轮 Sprocket	护栏 Guide	弯轨 Guide Rails	其余配件 Component
S49	R01-R42	—	C01-C57

Har2580 Series Rubber Top Flexible Chains

FLEXIBLE CHAINS

FLEXIBLE CHAINS 2580 Series

P=44mm, T=37.5mm

PIN:Stainless steel



节距 Pitch	链板材质 Material	颜色 Color
44mm	POM	白色/White

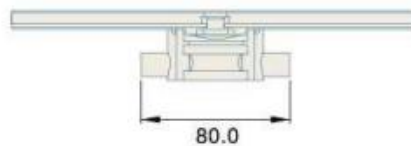
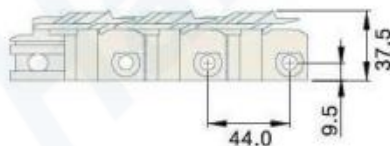
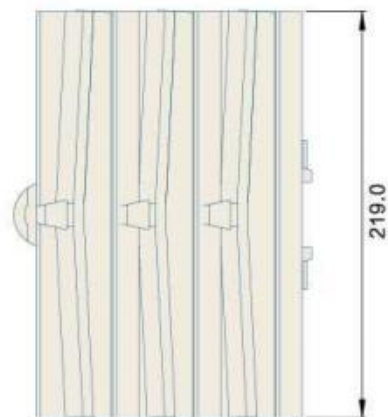

型号 Type No.	宽度 Width (mm)	节距 Pitch (mm)	重量 Weight (Kg/m)	转弯半径 Radius (mm)	负载 Working Capacity (N)
Har2580	219	44	3.6	600	—

链轮 Sprocket	护栏 Guide	弯轨 Guide Rails	其余配件 Component
—	R01-R42	—	C01-C57

Har830T Series FLEXIBLE CHAINS

FLEXIBLE CHAINS 830T Series
P=31.75mm, T=20.0mm
PIN:Stainless steel



节距 Pitch	链板材质 Material	颜色 Color
31.75mm	POM	咖啡色/Brown

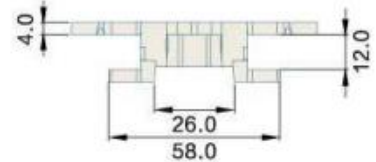
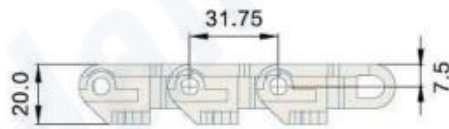
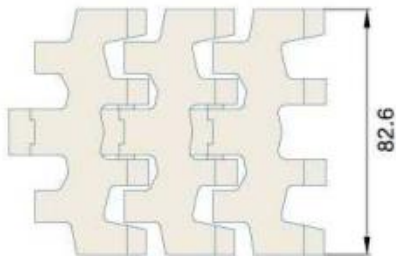

型号 Type No.	宽度 Width (mm)	节距 Pitch (mm)	重量 Weight (Kg/m)	转弯半径 Radius (mm)	负载 Working Capacity (N)
Har830T-K325	82.6	31.75	0.91	160	2100

链轮 Sprocket	护栏 Guide	弯轨 Guide Rails	其余配件 Component
S16	R01-R42	G07	C01-C57

Har1900A Series FLEXIBLE CHAINS

FLEXIBLE CHAINS 1900A Series
P=12.7mm, T=12.7mm
PIN:Stainless steel

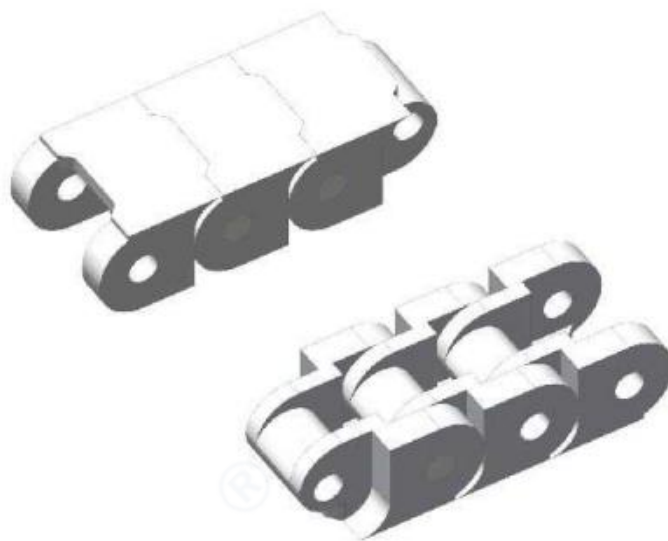

节距 Pitch	链板材质 Material	颜色 Color
12.7mm	POM	白色/White

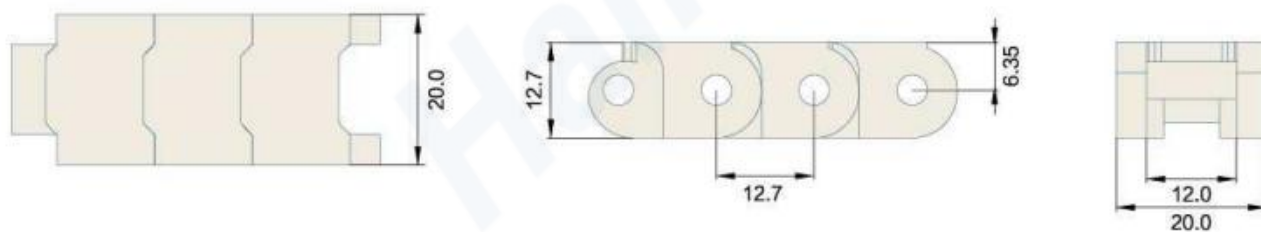

型号 Type No.	宽度 Width (mm)	节距 Pitch (mm)	重量 Weight (Kg/m)	转弯半径 Radius (mm)	负载 Working Capacity (N)
Har1900A	20.0	12.7	0.60	—	750

链轮 Sprocket	护栏 Guide	弯轨 Guide Rails	其余配件 Component
S36	R01-R42	—	C01-C57

Har1900B Series FLEXIBLE CHAINS

FLEXIBLE CHAINS 1900B Series
P=19.05mm, T=17mm
PIN:Stainless steel

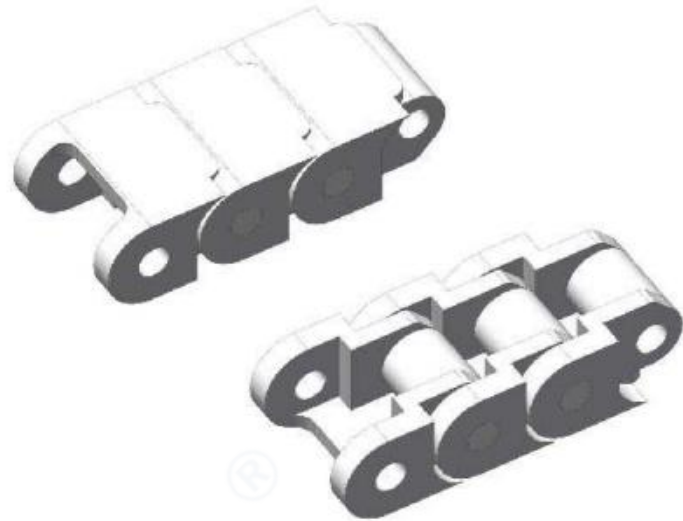

节距 Pitch	链板材质 Material	颜色 Color
19.05mm	POM	白色/White

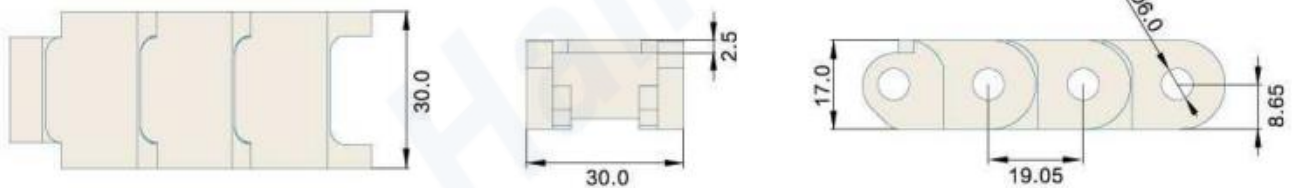

型号 Type No.	宽度 Width (mm)	节距 Pitch (mm)	重量 Weight (Kg/m)	转弯半径 Radius (mm)	负载 Working Capacity (N)
Har1900B	30.0	19.05	0.92	—	800

链轮 Sprocket	护栏 Guide	弯轨 Guide Rails	其余配件 Component
S36	R01-R42	—	C01-C57

Har1900C Series FLEXIBLE CHAINS

FLEXIBLE CHAINS 1900C Series
P=15.87mm, T=14.0mm
PIN:Stainless steel

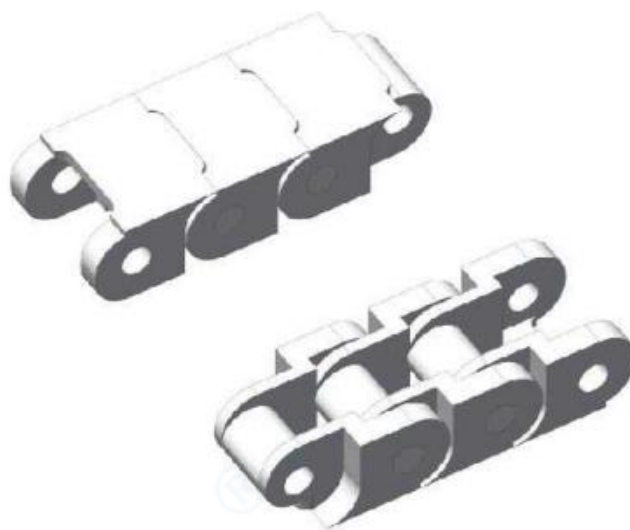

节距 Pitch	链板材质 Material	颜色 Color
15.87mm	POM	白色/White

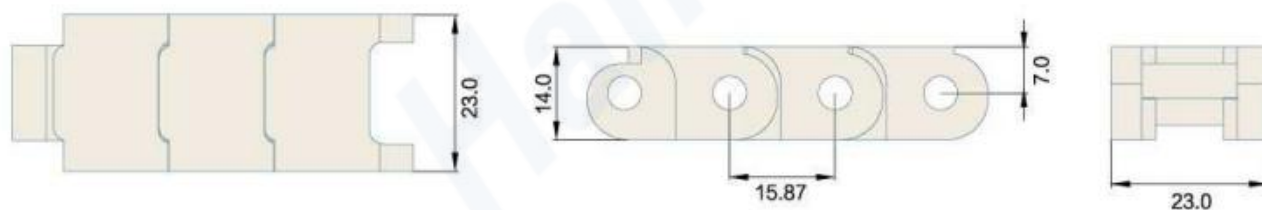

型号 Type No.	宽度 Width (mm)	节距 Pitch (mm)	重量 Weight (Kg/m)	转弯半径 Radius (mm)	负载 Working Capacity (N)
Har1900C	23.0	15.87	0.90	—	800

链轮 Sprocket	护栏 Guide	弯轨 Guide Rails	其余配件 Component
—	R01-R42	—	C01-C57

Har1800 Series FLEXIBLE CHAINS

FLEXIBLE CHAINS 1800
P=63.5mm, T=40mm
PIN:Stainless steel

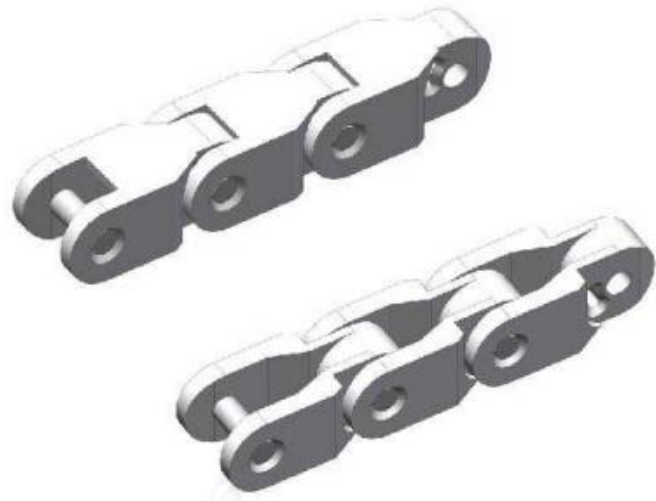

节距 Pitch	链板材质 Material	颜色 Color
63.5mm	POM	白色/White

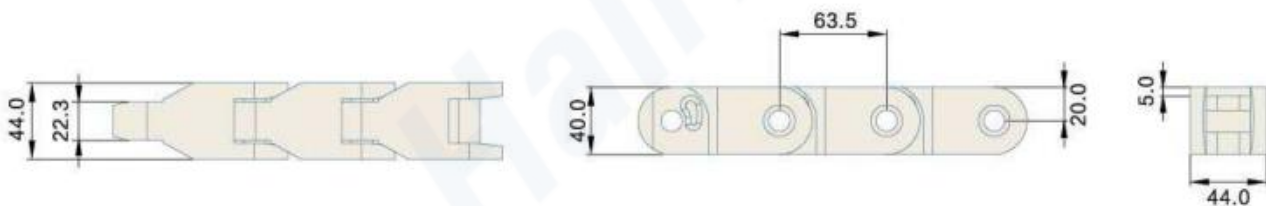

型号 Type No.	宽度 Width (mm)	节距 Pitch (mm)	重量 Weight (Kg/m)	转弯半径 Radius (mm)	负载 Working Capacity (N)
Har1800	44	63.5	2.0	—	4200

链轮 Sprocket	护栏 Guide	弯轨 Guide Rails	其余配件 Component
S39	R01-R42	—	C01-C57

Har50SG Series Flat Top MODULAR BELT

MODULAR BELT 50SG Series

P=5mm, T=6mm

OPEN AREA:0%

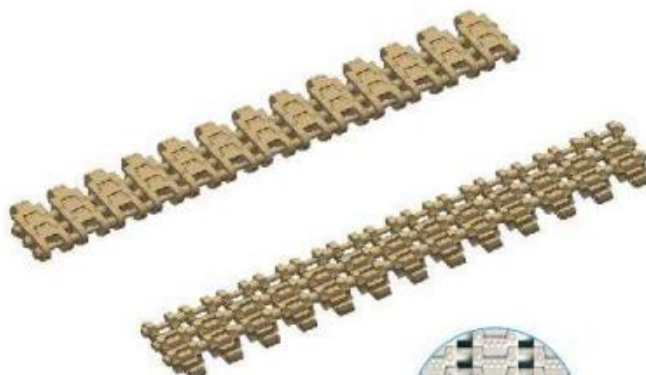

NEW TYPE

节距 Pitch	网链材质 Material	颜色 Color
5mm	POM	深蓝/Dark Blue

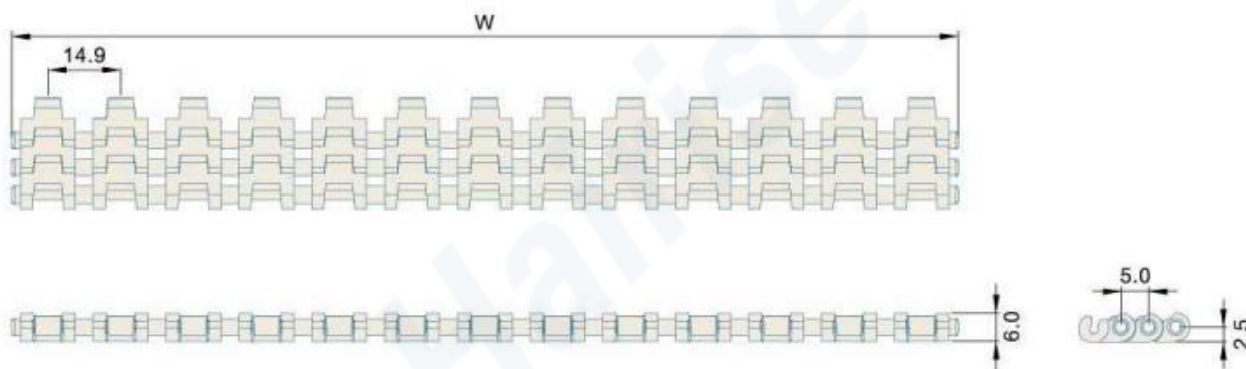

挡板高度 Cleat Height	—	材质 Material	重量 Weight(KG/SQ)	工作负荷 Working Capacity(N/M)
裙边高度 Side Apron Height	—	POM	5.3	2500
穿销材质 Pin Material	PP/NYLON/PBT	—	—	—

可选宽度 Available Width

塑料缩水率引致的正常误差: 正负差距 ±3(mm) The normal error caused by the shrinkage of plastic; ±3(mm)

单片宽度 (Bulk Pieces Width)	组合宽度 (Assemble Width)
194mm	194+15*N
非标宽度 Nonstandard Width	非标定制前请和本公司联系 PLS Contact Hairise Confirm Width Before Booking

链轮 Sprocket	护栏 Guide	其余配件 Component
S06	R01-R42	C01-C57

Har7900 Series Flat Top MODULAR BELT

MODULAR BELT 7900 Series
P=8mm, T=6mm
OPEN AREA:0%

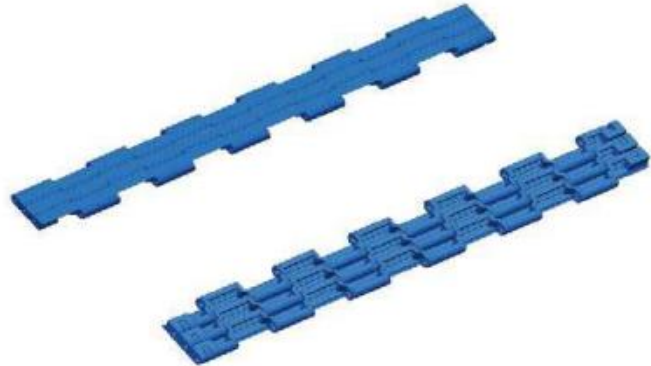

节距 Pitch	网链材质 Material	颜色 Color
8mm	POM	深蓝色/Dark Blue

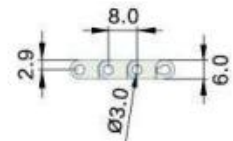
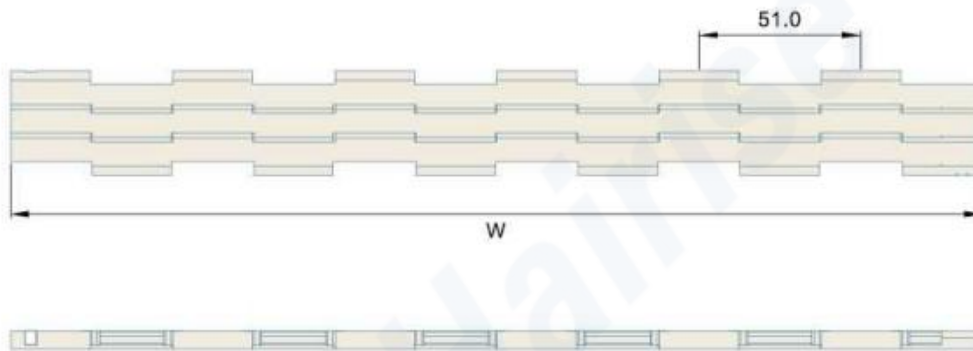

挡板高度 Cleat Height	—	材质 Material	重量 Weight(KG/SQ)	工作负荷 Working Capacity(N/M)
裙边高度 Side Apron Height	—	POM	5.3	2500
穿销材质 Pin Material	PP/NYLON/PBT DIAMETER:3mm	—	—	—
可选宽度 Available Width 塑料缩水率引致的正常误差：正负差距 ±3(mm) The normal error caused by the shrinkage of plastic: ±3(mm)				
单片宽度 (Bulk Pieces Width)			组合宽度 (Assemble Width)	
101mm	152mm	203mm	101+203+152*N	
非标宽度 Nonstandard Width			非标定制前请和本公司联系 PLS Contact Hairise Confirm Width Before Booking	

链轮 Sprocket	护栏 Guide	其余配件 Component
S58	R01-R42	C01-C57

Har7900 Series Nub Top MODULAR BELT

MODULAR BELT 7900 Series
P=8mm, T=6mm
OPEN AREA:0%

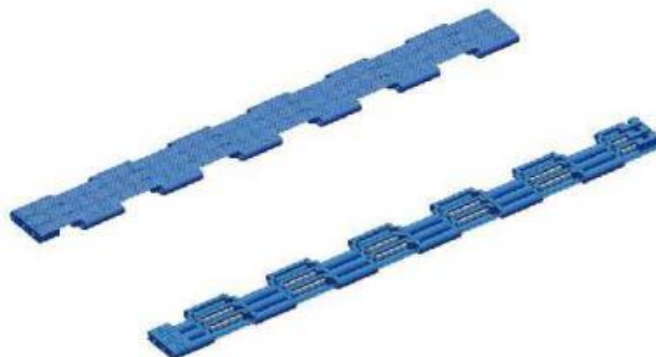

节距 Pitch	网链材质 Material	颜色 Color
8mm	POM	深蓝色/Dark Blue

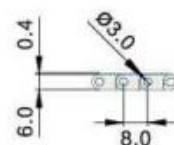
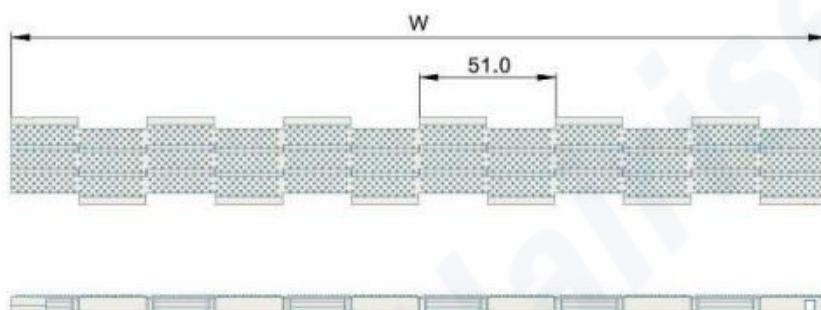

挡板高度 Cleat Height	—	材质 Material	重量 Weight(KG/SQ)	工作负荷 Working Capacity(N/M)
裙边高度 Side Apron Height	—	POM	5.3	2500
穿销材质 Pin Material	PP/NYLON/PBT DIAMETER:3mm	—	—	—
可选宽度 Available Width 塑料缩水率引起的正常误差：正负差距 ±3(mm) The normal error caused by the shrinkage of plastic: ±3(mm)				
单片宽度 (Bulk Pieces Width)			组合宽度 (Assemble Width)	
101mm	152mm	203mm	101+203+152*N	
非标宽度 Nonstandard Width			非标定制前请和本公司联系 PLS Contact Hairise Confirm Width Before Booking	

链轮 Sprocket	护栏 Guide	其余配件 Component
S58	R01-R42	C01-C57

Har7930 Series Flat Top MODULAR BELT

MODULAR BELT 7930 Series
P=10mm, T=7mm
OPEN AREA:0%



节距 Pitch	网链材质 Material	颜色 Color
10mm	POM	白色/White

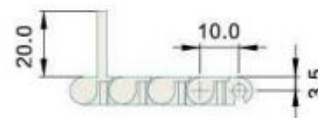
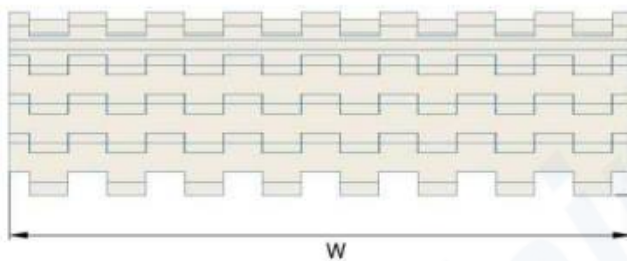

挡板高度 Cleat Height	20mm	材质 Material	重量 Weight(KG/SQ)	工作负荷 Working Capacity(N/M)
裙边高度 Side Apron Height	—	POM	5.8	5850
穿销材质 Pin Material	—	PP	4.9	4685

可选宽度 Available Width

塑料缩水率引起的正常误差：正负差距 ±3(mm) The normal error caused by the shrinkage of plastic: ±3(mm)

单片宽度 (Bulk Pieces Width)	组合宽度 (Assemble Width)
161mm	161*N
非标宽度 Nonstandard Width	非标定制前请和本公司联系 PLS Contact Hairise Confirm Width Before Booking

链轮 Sprocket	护栏 Guide	其余配件 Component
S60	R01-R42	C01-C57

Har7930 Series Flush Grid MODULAR BELT

MODULAR BELT 7930 Series
P=10mm, T=7mm
OPEN AREA:24%



节距 Pitch	网链材质 Material	颜色 Color
10mm	POM	白色/White
	PP	白色/White

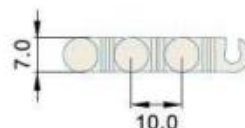
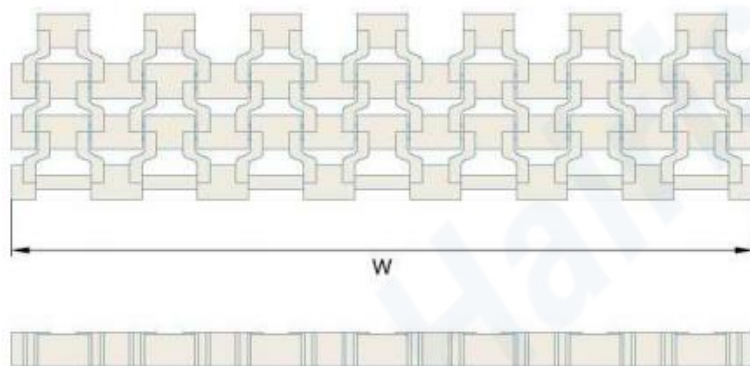

挡板高度 Cleat Height	20mm	材质 Material	重量 Weight(KG/SQ)	工作负荷 Working Capacity(N/M)
裙边高度 Side Apron Height	—	POM	3.9	4650
穿销材质 Pin Material	—	PP	3.8	3860
可选宽度 Available Width 塑料缩水率引致的正常误差：正负差距 ±3(mm) The normal error caused by the shrinkage of plastic; ±3(mm)				
单片宽度 (Bulk Pieces Width)		组合宽度 (Assemble Width)		
161mm		161*N		
非标宽度 Nonstandard Width		非标定制前请和本公司联系 PLS Contact Hairise Confirm Width Before Booking		

链轮 Sprocket	护栏 Guide	其余配件 Component
S60	R01-R42	C01-C57

Har500 Series Flush Grid MODULAR BELT

MODULAR BELT 500 Series
P=12.7mm, T=8.7mm
OPEN AREA:16%

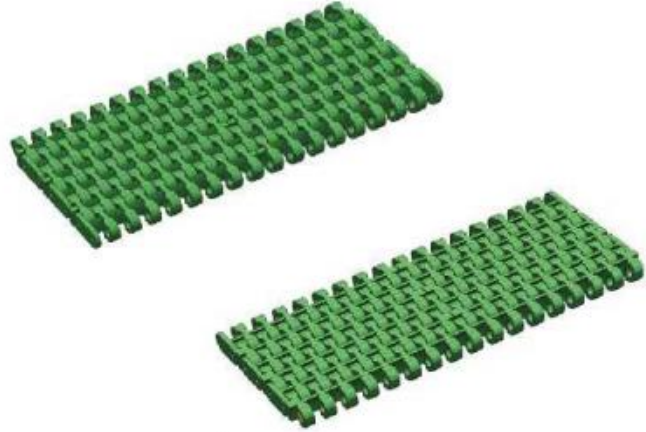

节距 Pitch	网链材质 Material	颜色 Color
12.7mm	POM	墨绿色/Dark Green

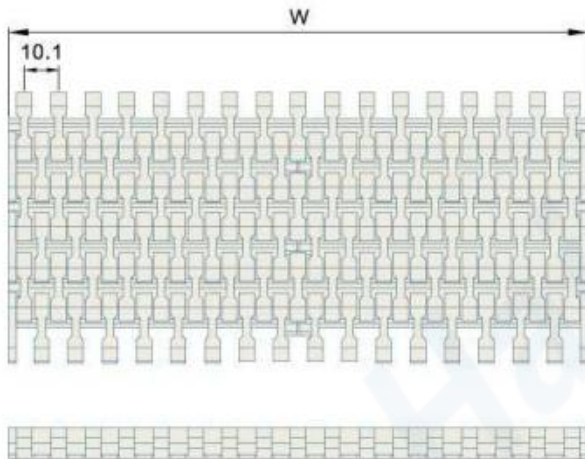

挡板高度 Cleat Height	—	材质 Material	重量 Weight(KG/SQ)	工作负荷 Working Capacity(N/M)
裙边高度 Side Apron Height	—	POM	7.06	14000
穿销材质 Pin Material	PP/NYLON/PBT DIAMETER:4.6mm	PP	4.76	10000
可选宽度 Available Width 塑料缩水率引致的正常误差：正负差距 ±3(mm) The normal error caused by the shrinkage of plastic: ±3(mm)				
单片宽度 (Bulk Pieces Width)		组合宽度 (Assemble Width)		
85mm	170mm	85*N		
非标宽度 Nonstandard Width		非标定制前请和本公司联系 PLS Contact Hairise Confirm Width Before Booking		

链轮 Sprocket	护栏 Guide	其余配件 Component
S05	R01-R42	C01-C57

Har510 Series Flush Grid MODULAR BELT

MODULAR BELT 510 Series
P=12.7mm, T=7.5mm
OPEN AREA:37%

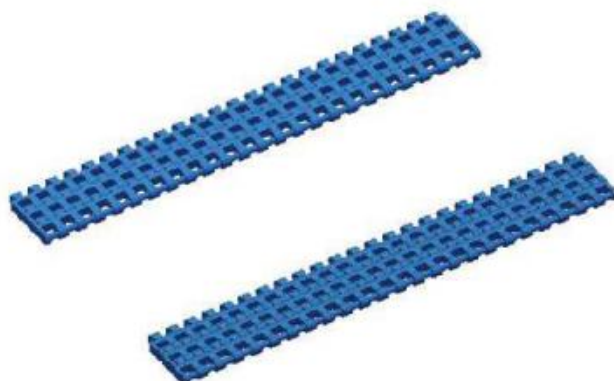

节距 Pitch	网链材质 Material	颜色 Color
12.7mm	POM	浅蓝/ Blue

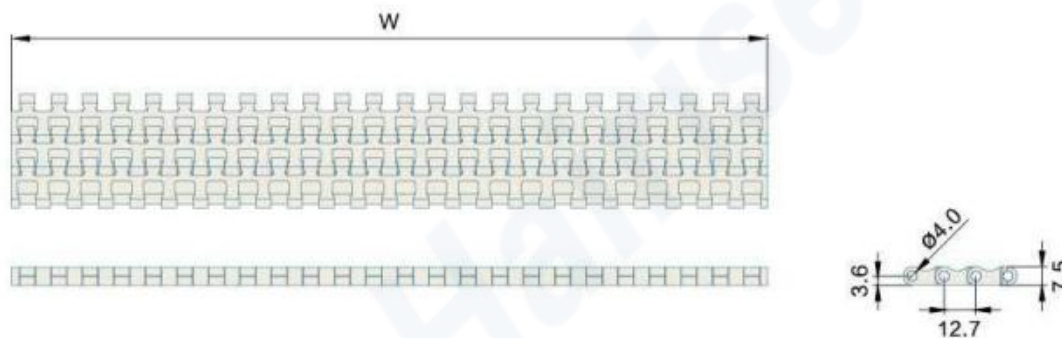

挡板高度 Cleat Height	—	材质 Material	重量 Weight(KG/SQ)	工作负荷 Working Capacity(N/M)
裙边高度 Side Apron Height	—	POM	7.0	20000
穿销材质 Pin Material	PP/NYLON/PBT DIAMETER:4mm	—	—	—
可选宽度 Available Width 塑料缩水率引致的正常误差：正负差距 ±3(mm) The normal error caused by the shrinkage of plastic: ±3(mm)				
单片宽度 (Bulk Pieces Width)		组合宽度 (Assemble Width)		
305mm		305*N		
非标宽度 Nonstandard Width		非标定制前请和本公司联系 PLS Contact Hairise Confirm Width Before Booking		

链轮 Sprocket	护栏 Guide	其余配件 Component
—	R01-R42	C01-C57

Har1270 Series Flat Top MODULAR BELT

MODULAR BELT 1270 Series
P=12.7mm, T=10mm
OPEN AREA:0%

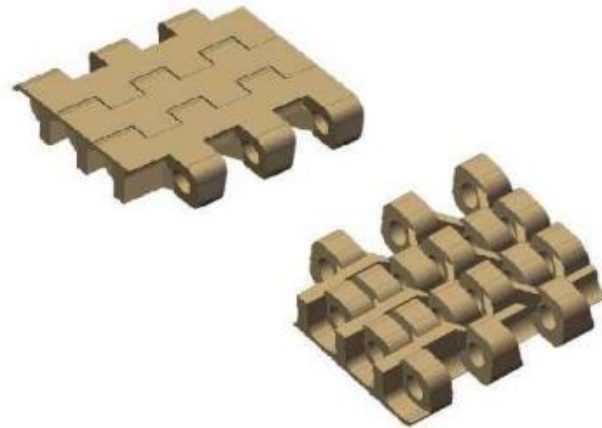

节距 Pitch	网链材质 Material	颜色 Color
12.0mm	POM	蓝色/Blue

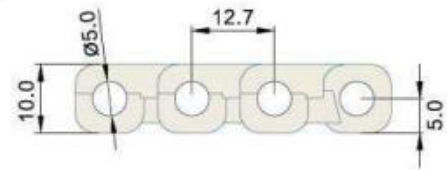
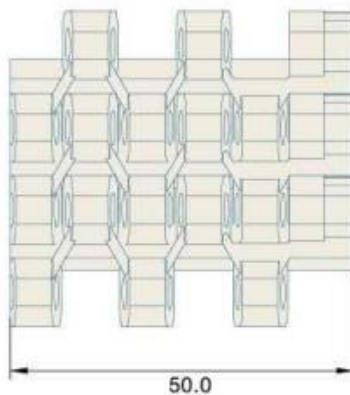

挡板高度 Cleat Height	—	材质 Material	重量 Weight(KG/SQ)	工作负荷 Working Capacity(N/M)
裙边高度 Side Apron Height	—	POM	8.7	18000
穿销材质 Pin Material	PP/NYLON/PBT DIAMETER:5mm	—	—	—
可选宽度 Available Width 塑料缩水率引起的正常误差: 正负差距 ±3(mm) The normal error caused by the shrinkage of plastic: ±3(mm)				
单片宽度 (Bulk Pieces Width)		组合宽度 (Assemble Width)		
50mm		50		
非标宽度 Nonstandard Width		非标定制前请和本公司联系 PLS Contact Hairise Confirm Width Before Booking		

链轮 Sprocket	护栏 Guide	其余配件 Component
S29	R01-R42	C01-C57

Har1270 Series Flat Top MODULAR BELT

MODULAR BELT 1270 Series
P=12.7mm, T=10mm
OPEN AREA:0%

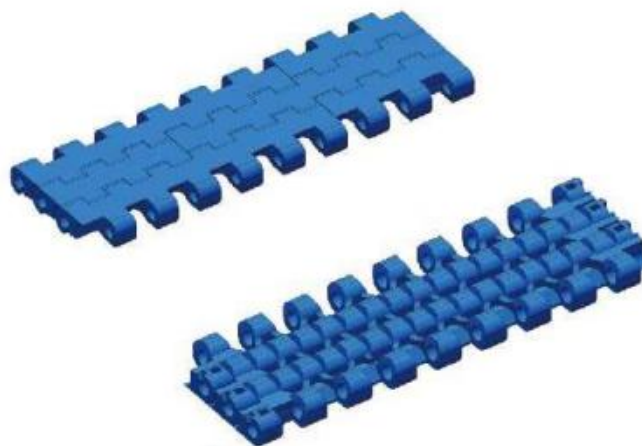

节距 Pitch	网链材质 Material	颜色 Color
12.7mm	POM	深蓝/ Dark Blue

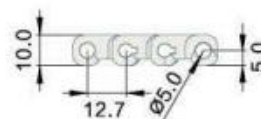
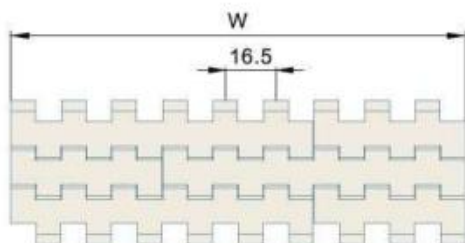

挡板高度 Cleat Height	—	材质 Material	POM	重量 Weight(KG/SQ)	8.7	工作负荷 Working Capacity(N/M)	16000
裙边高度 Side Apron Height	—						
穿销材质 Pin Material	PP/NYLON/PBT DIAMETER:5mm	—	—	—	—	—	—
可选宽度 Available Width 塑料缩水率引致的正常误差：正负差距 ±3(mm) The normal error caused by the shrinkage of plastic: ±3(mm)							
单片宽度 (Bulk Pieces Width)				组合宽度 (Assemble Width)			
50mm	100mm	200mm	50*N				
非标宽度 Nonstandard Width				非标定制前请和本公司联系 PLS Contact Hairise Confirm Width Before Booking			

链轮 Sprocket	护栏 Guide	其余配件 Component
S29	R01-R42	C01-C57

Har1270 Series Flush Grid MODULAR BELT

MODULAR BELT 1270 Series
P=12.7mm, T=10mm
OPEN AREA:25%



节距 Pitch	网链材质 Material	颜色 Color
12.7mm	POM	深蓝/ Dark Blue



挡板高度 Cleat Height	—	材质 Material	重量 Weight(KG/SQ)	工作负荷 Working Capacity(N/M)
裙边高度 Side Apron Height	—	POM	7.3	16000
穿销材质 Pin Material	PP/NYLON/PBT DIAMETER:5mm	—	—	—
可选宽度 Available Width 塑料缩水率引致的正常误差：正负差距 ±3(mm) The normal error caused by the shrinkage of plastic: ±3(mm)				
单片宽度 (Bulk Pieces Width)			组合宽度 (Assemble Width)	
50mm	100mm	200mm	50*N	
非标宽度 Nonstandard Width			非标定制前请和本公司联系 PLS Contact Hairise Confirm Width Before Booking	

链轮 Sprocket	护栏 Guide	其余配件 Component
S29	R01-R42	C01-C57

Har7120 Series Flush Grid

MODULAR BELT

MODULAR BELT 7120 Series

P=12.7mm, T=8.8mm

OPEN AREA:14%

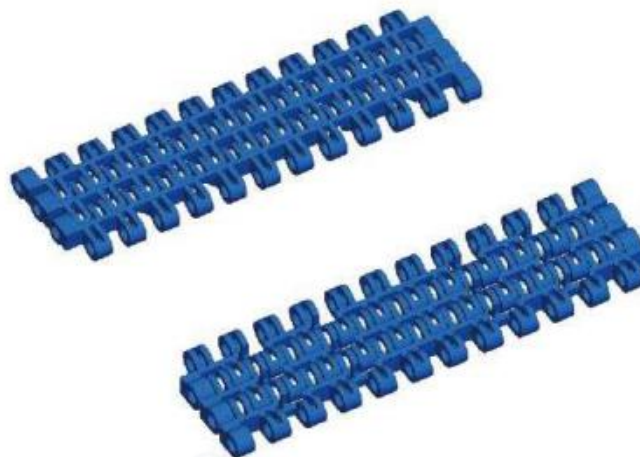

节距 Pitch	网链材质 Material	颜色 Color
12.7mm	POM	蓝色/Blue
	PP	蓝色/Blue

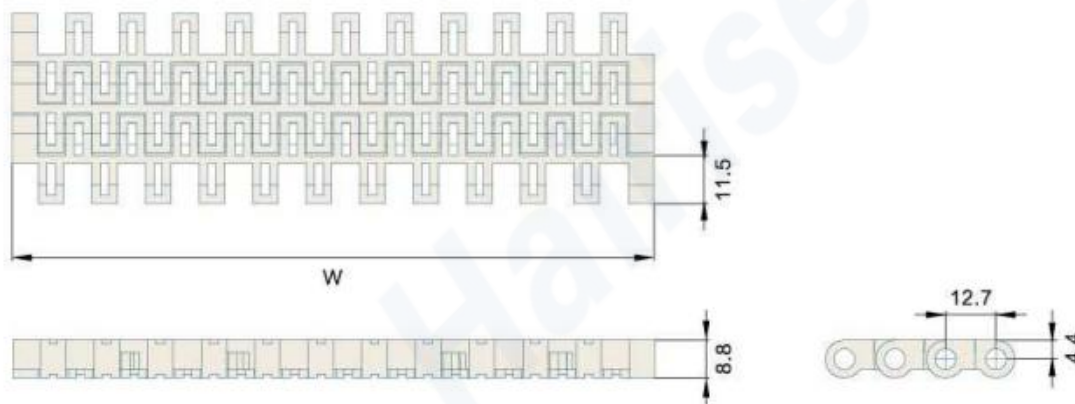

挡板高度 Cleat Height	—	材质 Material	重量 Weight(KG/SQ)	工作负荷 Working Capacity(N/M)
裙边高度 Side Apron Height	—	POM	8.2	16800
穿销材质 Pin Material	PP/NYLON/PBT DIAMETER:4.6mm	PP	6.1	12500
可选宽度 Available Width 塑料缩水率引起的正常误差：正负差距 ±3(mm) The normal error caused by the shrinkage of plastic: ±3(mm)				
单片宽度 (Bulk Pieces Width)		组合宽度 (Assemble Width)		
76mm	152mm	76*N		
非标宽度 Nonstandard Width		非标定制前请和本公司联系 PLS Contact Hairise Confirm Width Before Booking		

链轮 Sprocket	护栏 Guide	其余配件 Component
S55	R01-R42	C01-C57

Har7940 Series Flush Grid MODULAR BELT

MODULAR BELT 7940
P=12.7mm, T=7mm
OPEN AREA:48%

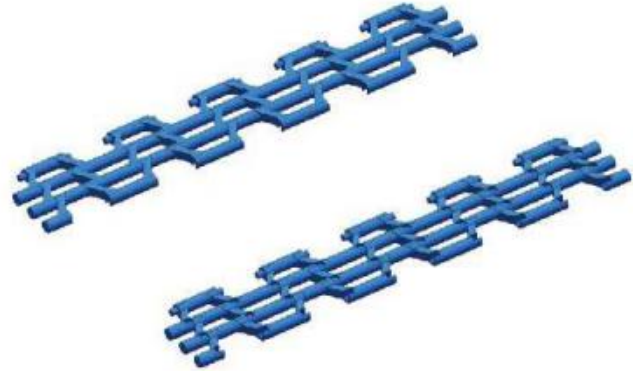

节距 Pitch	网链材质 Material	颜色 Color
12.7mm	POM	蓝色/Blue
	PP	白色/White

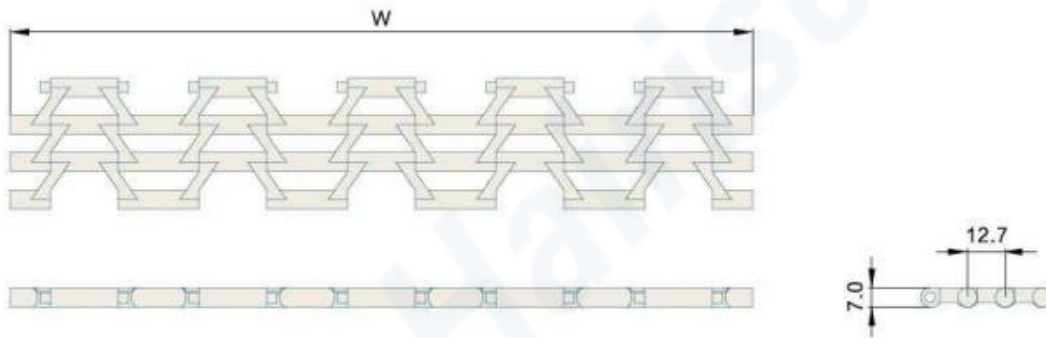

挡板高度 Cleat Height	—	材质 Material	重量 Weight(KG/SQ)	工作负荷 Working Capacity(N/M)
裙边高度 Side Apron Height	—	POM	3.8	3570
穿销材质 Pin Material	—	PP	2.5	1860
可选宽度 Available Width 塑料缩水率引致的正常误差：正负差距 ±3(mm) The normal error caused by the shrinkage of plastic; ±3(mm)				
单片宽度 (Bulk Pieces Width)		组合宽度 (Assemble Width)		
255mm		51*N		
非标宽度 Nonstandard Width		非标定制前请和本公司联系 PLS Contact Hairise Confirm Width Before Booking		

链轮 Sprocket	护栏 Guide	其余配件 Component
S60	R01-R42	C01-C57

Har1500 Series Flat Top MODULAR BELT

MODULAR BELT 1500 Series
P=12.7mm, T=8.7mm
OPEN AREA:0%

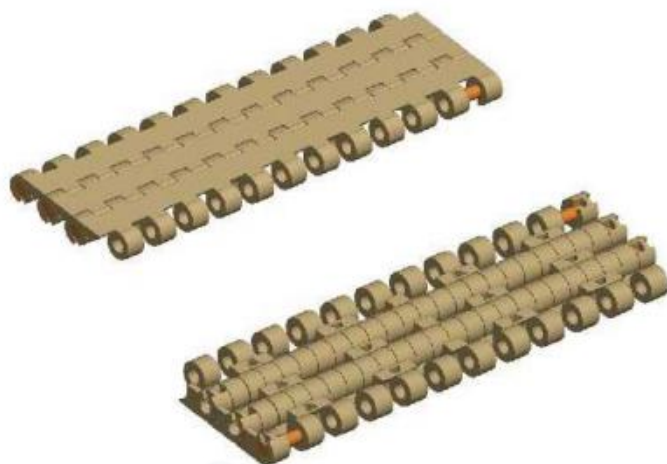

节距 Pitch	网链材质 Material	颜色 Color
12.7mm	POM	白色/White 蓝色/Blue
12.7mm	PP	白色/White 蓝色/Blue

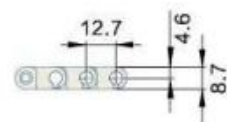
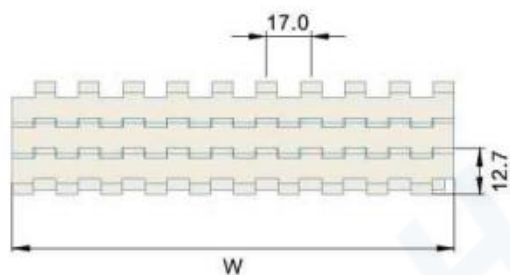

挡板高度 Cleat Height	—	材质 Material	重量 Weight(KG/SQ)	工作负荷 Working Capacity(N/M)
裙边高度 Side Apron Height	—	POM	8.1	17000
穿销材质 Pin Material	PP/NYLON/PBT DIAMETER:4.6mm	PP	6.0	17000
可选宽度 Available Width 塑料缩水率引致的正常误差：正负差距 ±3(mm) The normal error caused by the shrinkage of plastic: ±3(mm)				
单片宽度 (Bulk Pieces Width)		组合宽度 (Assemble Width)		
152mm		152+76*N		
非标宽度 Nonstandard Width		非标定制前请和本公司联系 PLS Contact Hairise Confirm Width Before Booking		

链轮 Sprocket	护栏 Guide	其余配件 Component
S31	R01-R42	C01-C57

Har2120 Series Flat Top MODULAR BELT

MODULAR BELT 2120 Series
P=12.7mm, T=8.7mm
OPEN AREA:0%



节距 Pitch	网链材质 Material	颜色 Color
12.7mm	POM	蓝色/Blue
12.7mm	POM	深灰色/Dark Grey

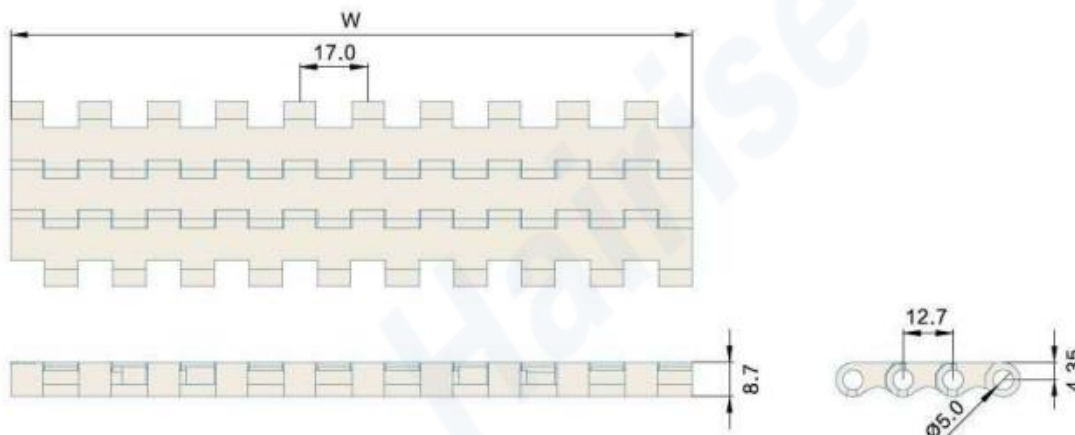

挡板高度 Cleat Height	—	材质 Material	重量 Weight(KG/SQ)	工作负荷 Working Capacity(N/M)
裙边高度 Side Apron Height	—	PP	6.5	17000
穿销材质 Pin Material	PP/NYLON/PBT DIAMETER:5mm	POM	8.8	20000
可选宽度 Available Width 塑料缩水率引致的正常误差：正负差距 ±3(mm) The normal error caused by the shrinkage of plastic: ±3(mm)				
单片宽度 (Bulk Pieces Width)		组合宽度 (Assemble Width)		
85mm	170mm	85*N		
非标宽度 Nonstandard Width		非标定制前请和本公司联系 PLS Contact Hairise Confirm Width Before Booking		

链轮 Sprocket	护栏 Guide	其余配件 Component
S38	R01-R42	C01-C57

Har2120 Series Rubber Top MODULAR BELT

MODULAR BELT 2120 Series
P=12.7mm, T=8.7mm

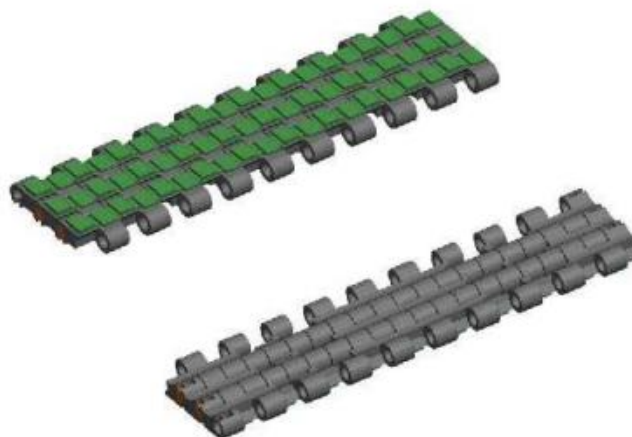

节距 Pitch	网链材质 Material	颜色 Color
12.7mm	PP	灰底绿胶/ grey plate green rubber

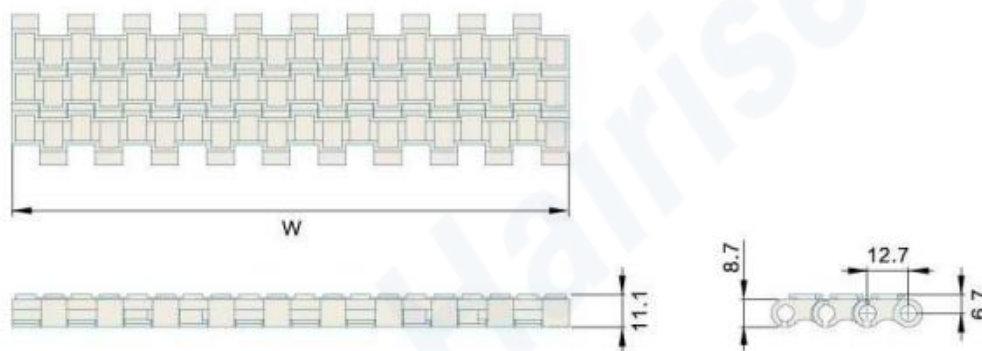

挡板高度 Cleat Height	—	材质 Material	PP	重量 Weight(KG/SQ)	9.7	工作负荷 Working Capacity(N/M)	18000
裙边高度 Side Apron Height	—						
穿销材质 Pin Material	PP/NYLON/PBT DIAMETER:5mm	—	—	—	—	—	—
可选宽度 Available Width 塑料缩水率引起的正常误差：正负差距 ±3(mm) The normal error caused by the shrinkage of plastic: ±3(mm)							
单片宽度 (Bulk Pieces Width)		组合宽度 (Assemble Width)					
85mm	170mm	85*N					
非标宽度 Nonstandard Width		非标定制前请和本公司联系 PLS Contact Hairise Confirm Width Before Booking					

链轮 Sprocket	护栏 Guide	其余配件 Component
S38	R01-R42	C01-C57

Har2120 Series Flat Top With Positrack

MODULAR BELT

MODULAR BELT 2120 Series
P=12.7mm, T=8.7mm

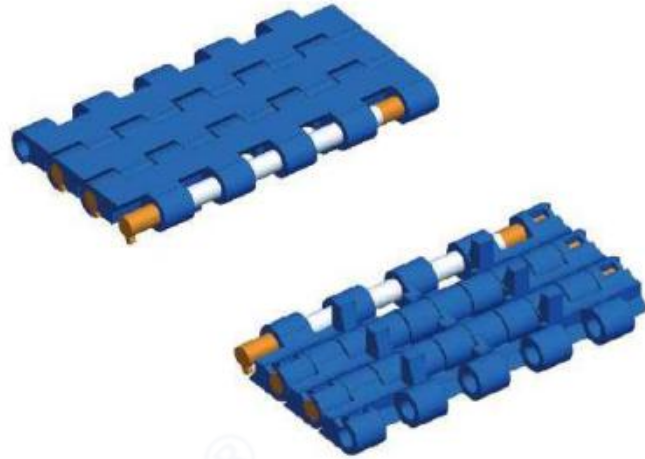

节距 Pitch	网链材质 Material	颜色 Color
12.7mm	POM	灰色/ Dark Gray 蓝色/Blue

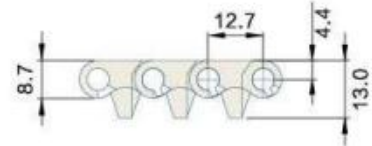
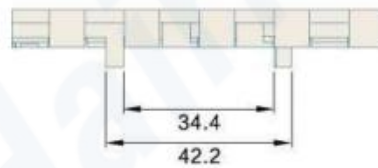
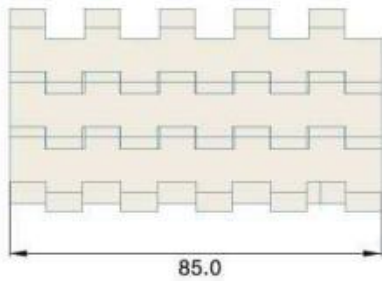

挡板高度 Cleat Height	—	材质 Material	重量 Weight(KG/SQ)	工作负荷 Working Capacity(N/M)
裙边高度 Side Apron Height	—	POM	8.8	20000
穿销材质 Pin Material	PP/NYLON/PBT DIAMETER:5mm	—	—	—

可选宽度 Available Width

塑料缩水率引致的正常误差: 正负差距 ±3(mm) The normal error caused by the shrinkage of plastic: ±3(mm)

单片宽度 (Bulk Pieces Width)		组合宽度 (Assemble Width)
85mm	170mm	85*N
非标宽度 Nonstandard Width		非标定制前请和本公司联系 PLS Contact Hairise Confirm Width Before Booking

链轮 Sprocket	护栏 Guide	其余配件 Component
S38	R01-R42	C01-C57

Har2120 Series Flat Top MODULAR BELT

MODULAR BELT 2120 Series
P=12.7mm, T=8.7mm



节距 Pitch	网链材质 Material	颜色 Color
12.7mm	POM	灰色/ Dark Gray 蓝色/Blue

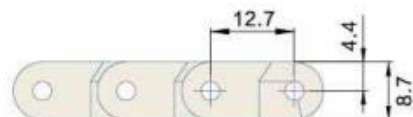
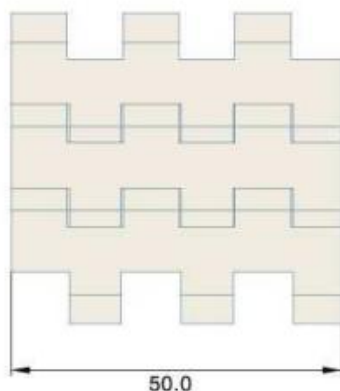

挡板高度 Cleat Height	—	材质 Material	POM	重量 Weight(KG/SQ)	8.8	工作负荷 Working Capacity(N/M)	20000
裙边高度 Side Apron Height	—						
穿销材质 Pin Material	PP/NYLON/PBT DIAMETER:5mm	—	—	—	—	—	—
可选宽度 Available Width 塑料缩水率引致的正常误差：正负差距 ±3(mm) The normal error caused by the shrinkage of plastic: ±3(mm)							
单片宽度 (Bulk Pieces Width)				组合宽度 (Assemble Width)			
50mm				50mm			
非标宽度 Nonstandard Width				非标定制前请和本公司联系 PLS Contact Hairise Confirm Width Before Booking			

链轮 Sprocket	护栏 Guide	其余配件 Component
S38	R01-R42	C01-C57

Har1100 Series Flat Top MODULAR BELT

MODULAR BELT 1100 Series
P=15.2mm, T=8.7mm
OPEN AREA:0%



节距 Pitch	网链材质 Material	颜色 Color
15.2mm	PP/POM	蓝色/Blue

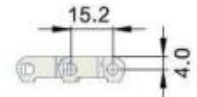
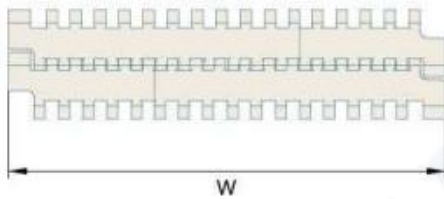

挡板高度 Cleat Height	5mm/50mm	材质 Material	重量 Weight(KG/SQ)	工作负荷 Working Capacity(N/M)
裙边高度 Side Apron Height	—	PP	4.5	7500
穿销材质 Pin Material	PP/NYLON/PBT DIAMETER:4.6mm	POM	6.5	14900
可选宽度 Available Width 塑料缩水率引致的正常误差：正负差距 ±3(mm) The normal error caused by the shrinkage of plastic: ±3(mm)				
单片宽度 (Bulk Pieces Width)			组合宽度 (Assemble Width)	
51mm	100mm	101mm	51+100+51*N	
非标宽度 Nonstandard Width			非标定制前请和本公司联系 PLS Contact Hairise Confirm Width Before Booking	

链轮 Sprocket	护栏 Guide	其余配件 Component
S27-S28	R01-R42	C01-C57

Har1100 Series Flush Grid MODULAR BELT

MODULAR BELT 1100 Series
P=15.2mm, T=8.7mm
OPEN AREA:28%



节距 Pitch	网链材质 Material	颜色 Color
15.2mm	POM	蓝色/Blue
15.2mm	PP	灰色/Gray

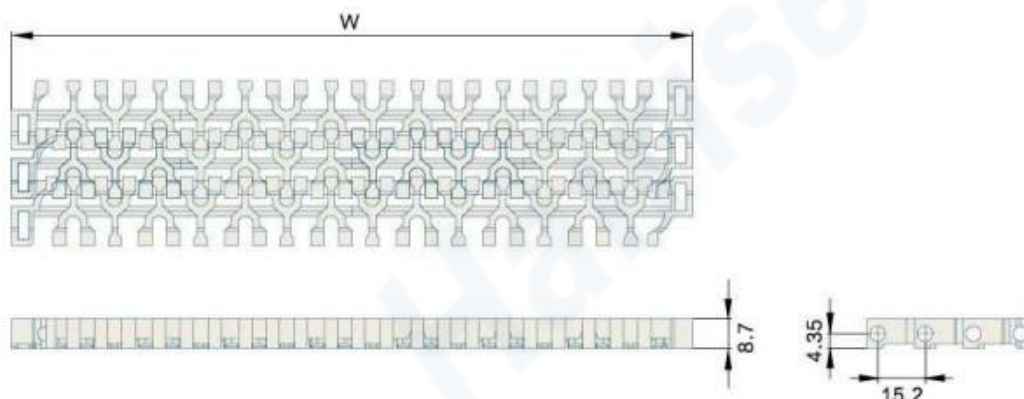

挡板高度 Cleat Height	5/50mm	材质 Material	POM	重量 Weight(KG/SQ)	5.80	工作负荷 Working Capacity(N/M)	14000
裙边高度 Side Apron Height	—						
穿销材质 Pin Material	PP/NYLON/PBT DIAMETER:4.6mm	PP		3.95		9000	
可选宽度 Available Width 塑料缩水率引起的正常误差：正负差距 ±3(mm) The normal error caused by the shrinkage of plastic: ±3(mm)							
单片宽度 (Bulk Pieces Width)				组合宽度 (Assemble Width)			
50mm	152mm	100mm	50+100+50*N				
非标宽度 Nonstandard Width				非标定制前请和本公司联系 PLS Contact Hairise Confirm Width Before Booking			

链轮 Sprocket	护栏 Guide	其余配件 Component
S27-S28	R01-R42	C01-C57

Har1100 Series Rubber Top MODULAR BELT

MODULAR BELT 1100 Series
P=15.2mm, T=8.7mm
OPEN AREA:28%



节距 Pitch	网链材质 Material	颜色 Color
15.2mm	PP	灰底灰胶/Grey Plate Grey Rubber 灰底黑胶/Grey Plate Black Rubber 白底白胶/White Plate White Rubber

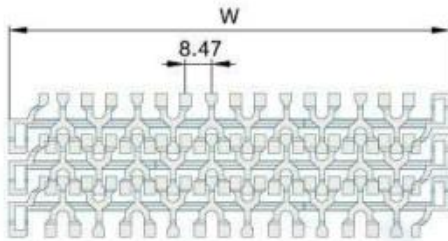

挡板高度 Cleat Height	—	材质 Material	重量 Weight(KG/SQ)	工作负荷 Working Capacity(N/M)
裙边高度 Side Apron Height	—	PP	5.75	9000
穿销材质 Pin Material	PP/NYLON/PBT DIAMETER:4.6mm	—	—	—
可选宽度 Available Width 塑料缩水率引致的正常误差：正负差距 ±3(mm) The normal error caused by the shrinkage of plastic; ±3(mm)				
单片宽度 (Bulk Pieces Width)			组合宽度 (Assemble Width)	
50mm	152mm	100mm	50+100+50*N	
非标宽度 Nonstandard Width			非标定制前请和本公司联系 PLS Contact Hairise Confirm Width Before Booking	

链轮 Sprocket	护栏 Guide	其余配件 Component
S27-S28	R01-R42	C01-C57

Har1100 Series Flush Grid Dynamic Transition MODULAR BELT

MODULAR BELT 1100 Series
P=15.2mm, T=8.7mm
OPEN AREA:28%

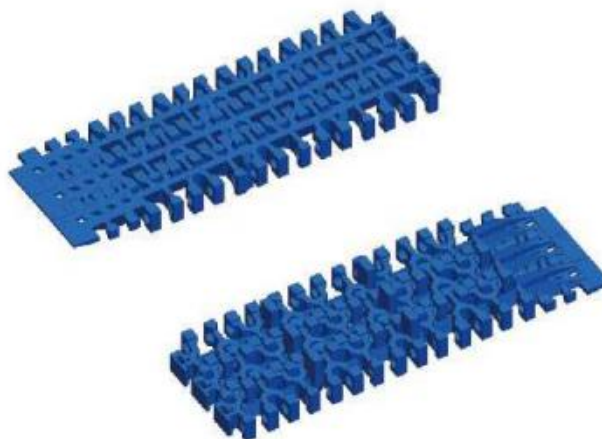

节距 Pitch	网链材质 Material	颜色 Color
15.2mm	POM	蓝色/Blue

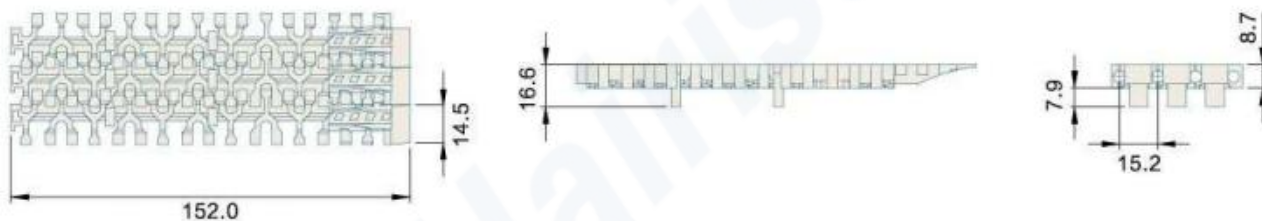

挡板高度 Cleat Height	—	材质 Material	重量 Weight(KG/SQ)	工作负荷 Working Capacity(N/M)
裙边高度 Side Apron Height	—	POM	5.8	19400
穿销材质 Pin Material	PP/NYLON/PBT DIAMETER:4.6mm	—	—	—
可选宽度 Available Width 塑料缩水率引致的正常误差: 正负差距 ±3(mm) The normal error caused by the shrinkage of plastic: ±3(mm)				
单片宽度 (Bulk Pieces Width)		组合宽度 (Assemble Width)		
152mm		152mm		
非标宽度 Nonstandard Width		非标定制前请和本公司联系 PLS Contact Hairise Confirm Width Before Booking		

链轮 Sprocket	护栏 Guide	其余配件 Component
S27-S28	R01-R42	C01-C57

Har1507 Series Flat Top MODULAR BELT

MODULAR BELT 1507 Series
P=15.2mm, T=8.7mm
OPEN AREA:0%



节距 Pitch	网链材质 Material	颜色 Color
15.2mm	POM	深棕色/Dark Brown

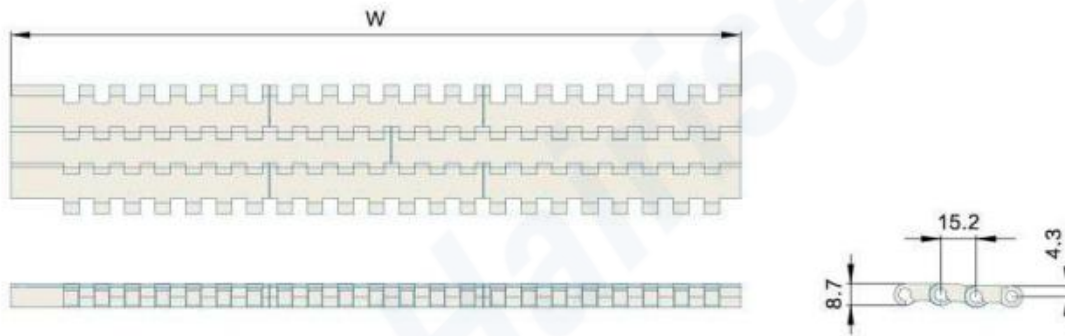

挡板高度 Cleat Height	—	材质 Material	POM	重量 Weight(KG/SQ)	7.0	工作负荷 Working Capacity(N/M)	13000
裙边高度 Side Apron Height	—	穿销材质 Pin Material	PP/NYLON/PBT DIAMETER:4.6mm	—	—	—	—
可选宽度 Available Width 塑料缩水率引致的正常误差：正负差距 ±3(mm) The normal error caused by the shrinkage of plastic: ±3(mm)							
单片宽度 (Bulk Pieces Width)			组合宽度 (Assemble Width)				
108mm	147mm	159mm	108+147+159*N				
非标宽度 Nonstandard Width			非标定制前请和本公司联系 PLS Contact Hairise Confirm Width Before Booking				

链轮 Sprocket	护栏 Guide	其余配件 Component
S32	R01-R42	C01-C57

Har1100 Series Roller Top MODULAR BELT

MODULAR BELT 1100 Series
P=15.2mm, T=8.7mm
OPEN AREA:12.5%



节距 Pitch	网链材质 Material	颜色 Color
15.2mm	POM	黑色+黄色珠子 Black with yellow roller

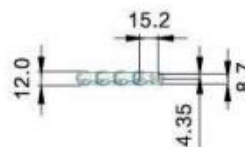
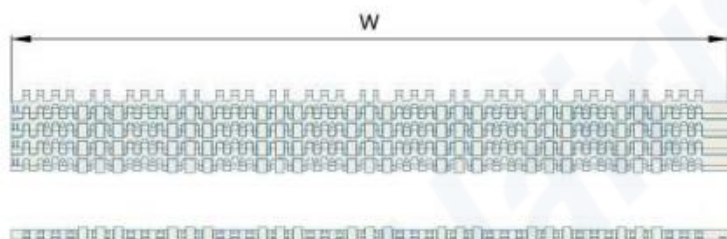

挡板高度 Cleat Height	—	材质 Material	POM	重量 Weight(KG/SQ)	8.3	工作负荷 Working Capacity(N/M)	35000
裙边高度 Side Apron Height	—						
穿销材质 Pin Material	PP/NYLON/PBT DIAMETER:4.6mm	—	—	—	—	—	—
可选宽度 Available Width 塑料缩水率引起的正常误差: 正负差距 ±3(mm) The normal error caused by the shrinkage of plastic: ±3(mm)							
单片宽度 (Bulk Pieces Width)		组合宽度 (Assemble Width)					
76mm	152mm	76*N					
非标宽度 Nonstandard Width		非标定制前请和本公司联系 PLS Contact Hairise Confirm Width Before Booking					

链轮 Sprocket	护栏 Guide	其余配件 Component
S40	R01-R42	C01-C57

Har1505 Series Flat Top MODULAR BELT

MODULAR BELT 1505 Series
P=15.2mm, T=8.7mm

节距 Pitch	网链材质 Material	颜色 Color
15.2 mm	POM	灰色/Gray 墨绿色/Dark Green
15.2 mm	PP	灰色/Gray 墨绿色/Dark Green

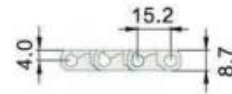
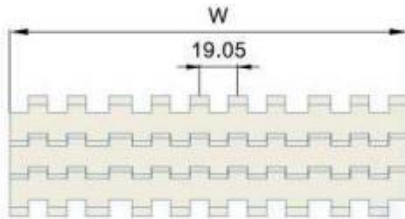

挡板高度 Cleat Height	—	材质 Material	重量 Weight(KG/SQ)	工作负荷 Working Capacity(N/M)
裙边高度 Side Apron Height	—	POM	6.58	22000
穿销材质 Pin Material	PP/NYLON/PBT DIAMETER:4.6mm	PP	4.43	14000
可选宽度 Available Width 塑料缩水率引致的正常误差：正负差距 ±3(mm) The normal error caused by the shrinkage of plastic; ±3(mm)				
单片宽度 (Bulk Pieces Width)		组合宽度 (Assemble Width)		
170mm		170+85*N		
非标宽度 Nonstandard Width		非标定制前请和本公司联系 PLS Contact Hairise Confirm Width Before Booking		

链轮 Sprocket	护栏 Guide	其余配件 Component
S31	R01-R42	C01-C57

Har1505 Series Rubber Top MODULAR BELT

MODULAR BELT 1505 Series
P=15.2mm, T=8.7mm
OPEN AREA:0%



节距 Pitch	网链材质 Material	颜色 Color
15.2mm	PP	绿底黑胶/ Green Plate Black Rubber

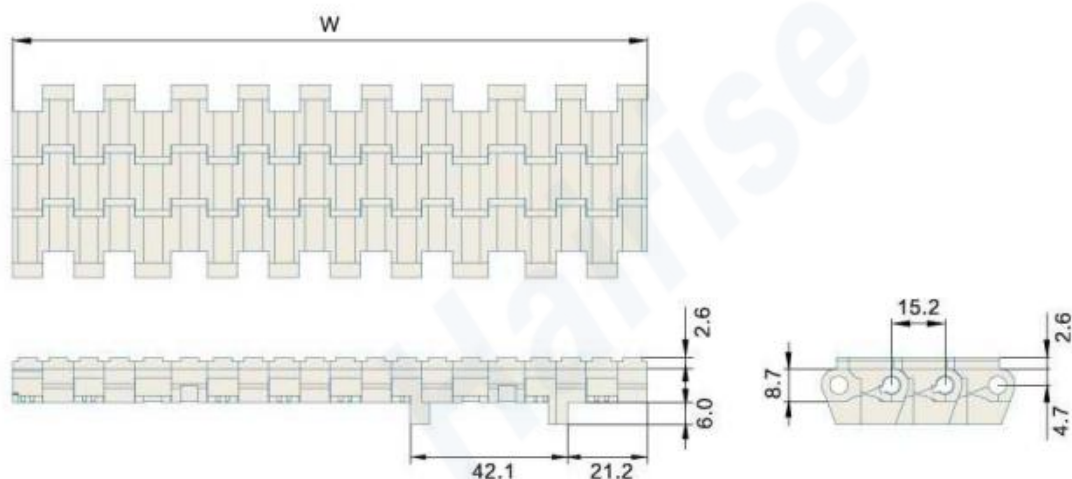

挡板高度 Cleat Height	—	材质 Material	重量 Weight(KG/SQ)	工作负荷 Working Capacity(N/M)
裙边高度 Side Apron Height	—	PP	6.4	7300
穿销材质 Pin Material	PP/NYLON/PBT DIAMETER:4.6mm	—	—	—
可选宽度 Available Width 塑料缩水率引致的正常误差: 正负差距 ±3(mm) The normal error caused by the shrinkage of plastic; ±3(mm)				
单片宽度 (Bulk Pieces Width)		组合宽度 (Assemble Width)		
170mm		170*N		
非标宽度 Nonstandard Width		非标定制前请和本公司联系 PLS Contact Hairise Confirm Width Before Booking		

链轮 Sprocket	护栏 Guide	其余配件 Component
S31	R01-R42	C01-C57

Har1506 Series Flat Top MODULAR BELT

MODULAR BELT 1506 Series
P=15.2mm, T=8.7mm
OPEN AREA:0%

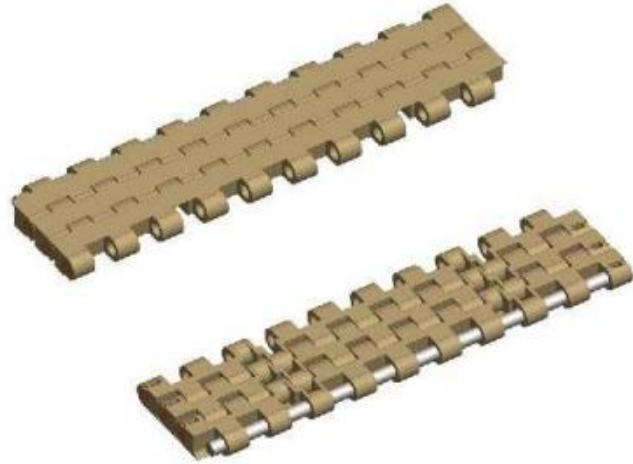

节距 Pitch	网链材质 Material	颜色 Color
15.2mm	POM	棕色/Brown

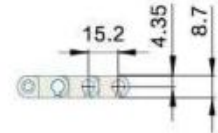
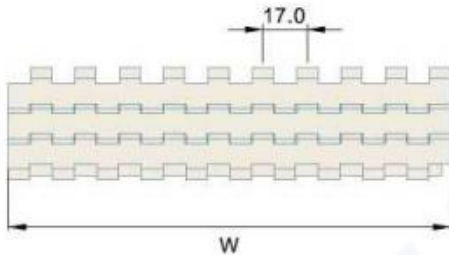

挡板高度 Cleat Height	—	材质 Material	重量 Weight(KG/SQ)	工作负荷 Working Capacity(N/M)
裙边高度 Side Apron Height	—	POM	6.8	13200
穿销材质 Pin Material	PP/NYLON/PBT DIAMETER:4.6mm	—	—	—
可选宽度 Available Width 塑料缩水率引致的正常误差：正负差距 ±3(mm) The normal error caused by the shrinkage of plastic; ±3(mm)				
单片宽度 (Bulk Pieces Width)		组合宽度 (Assemble Width)		
170mm	85mm	170+85*N		
非标宽度 Nonstandard Width		非标定制前请和本公司联系 PLS Contact Hairise Confirm Width Before Booking		

链轮 Sprocket	护栏 Guide	其余配件 Component
S32	R01-R42	C01-C57

Har8505 Series Flat Top MODULAR BELT

MODULAR BELT 8505 Series
P=19.05mm, T=8.7mm
OPEN AREA:0%

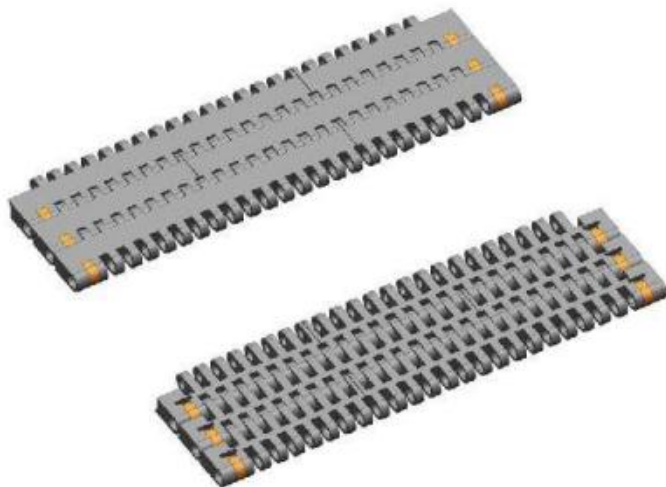

节距 Pitch	网链材质 Material	颜色 Color
19.05mm	POM	深棕色/Dark Brown

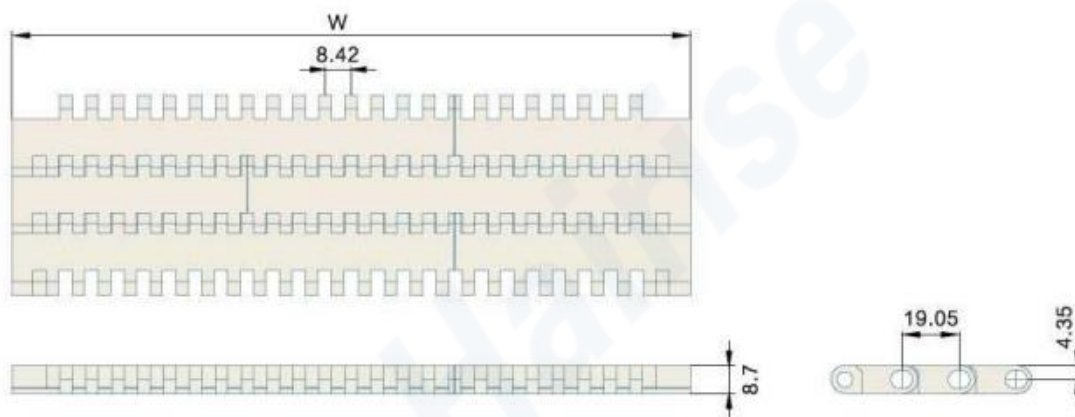

挡板高度 Cleat Height	—	材质 Material	重量 Weight(KG/SQ)	工作负荷 Working Capacity(N/M)
裙边高度 Side Apron Height	—	POM	8.89	29000
穿销材质 Pin Material	PP/NYLON/PBT DIAMETER:4.6mm	—	—	—
可选宽度 Available Width 塑料缩水率引致的正常误差; 正负差距 ±3(mm) The normal error caused by the shrinkage of plastic; ±3(mm)				
单片宽度 (Bulk Pieces Width)			组合宽度 (Assemble Width)	
76mm	303mm	152mm	76+303+152*N	
非标宽度 Nonstandard Width			非标定制前请和本公司联系 PLS Contact Hairise Confirm Width Before Booking	

链轮 Sprocket	护栏 Guide	其余配件 Component
S62-S63	R01-R42	C01-C57

Har8505 Series Raised Rib MODULAR BELT

MODULAR BELT 8505 Series
P=19.05mm, T=14.2mm
OPEN AREA:22%



节距 Pitch	网链材质 Material	颜色 Color
19.05mm	PP	棕色/Brown

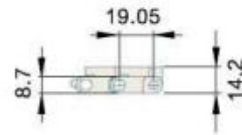
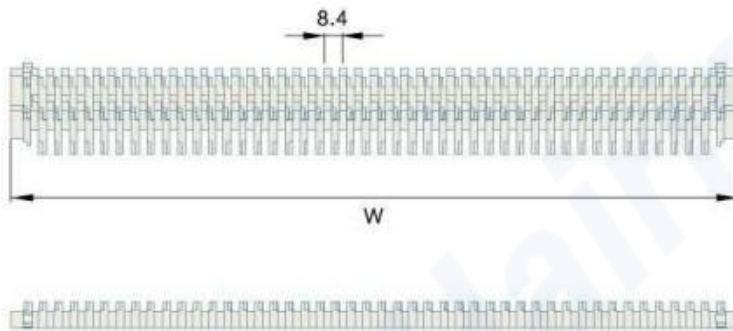

挡板高度 Cleat Height	—	材质 Material	重量 Weight(KG/SQ)	工作负荷 Working Capacity(N/M)
裙边高度 Side Apron Height	—	PP	6.9	16000
穿销材质 Pin Material	PP/NYLON/PBT DIAMETER:4.6mm	—	—	—
可选宽度 Available Width 塑料缩水率引致的正常误差; 正负差距 ±3(mm) The normal error caused by the shrinkage of plastic; ±3(mm)				
单片宽度 (Bulk Pieces Width)		组合宽度 (Assemble Width)		
304mm		—		
非标宽度 Nonstandard Width		非标定制前请和本公司联系 PLS Contact Hairise Confirm Width Before Booking		

链轮 Sprocket	护栏 Guide	其余配件 Component
S62-S63	R01-R42	C01-C57

Har8505 Series Flat Top Dynamic Transition MODULAR BELT

MODULAR BELT 8505 Series
P=19.05mm, T=8.7mm
OPEN AREA:0%



节距 Pitch	网链材质 Material	颜色 Color
19.05mm	POM	深棕色/Dark Brown

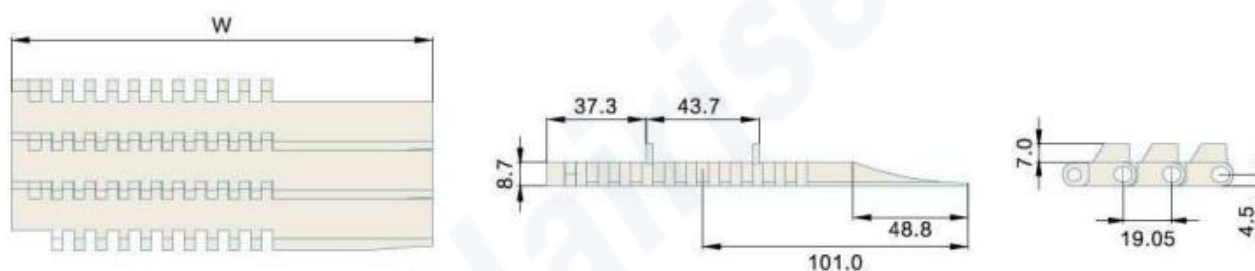

挡板高度 Cleat Height	—	材质 Material	重量 Weight(KG/M)	工作负荷 Working Capacity(N/M)
裙边高度 Side Apron Height	—	POM	1.4	4650
穿销材质 Pin Material	PP/NYLON/PBT DIAMETER:4.6mm	—	—	—
可选宽度 Available Width 塑料缩水率引致的正常误差：正负差距 ±3(mm) The normal error caused by the shrinkage of plastic: ±3(mm)				
单片宽度 (Bulk Pieces Width)		组合宽度 (Assemble Width)		
160mm		160mm		
非标宽度 Nonstandard Width		非标定制前请和本公司联系 PLS Contact Hairise Confirm Width Before Booking		

链轮 Sprocket	护栏 Guide	其余配件 Component
S62-S63	R01-R42	C01-C57

Har1990 Series Flat Top MODULAR BELT

MODULAR BELT 1990 Series
P=19.05mm, T=9.8mm



节距 Pitch	网链材质 Material	颜色 Color
19.05mm	PE	黑色/Black

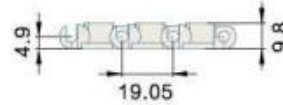
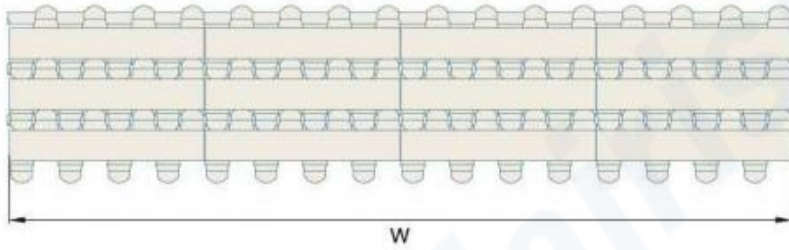

挡板高度 Cleat Height	—	材质 Material	重量 Weight(KG/SQ)	工作负荷 Working Capacity(N/M)
裙边高度 Side Apron Height	—	PE	5.0	7900N
穿销材质 Pin Material	—	PP	—	—

可选宽度 Available Width

塑料缩水率引致的正常误差; 正负差距 ±3(mm) The normal error caused by the shrinkage of plastic; ±3(mm)

单片宽度 (Bulk Pieces Width)	组合宽度 (Assemble Width)
153mm	153+76*N
非标宽度 Nonstandard Width	非标定制前请和本公司联系 PLS Contact Hairise Confirm Width Before Booking

链轮 Sprocket	护栏 Guide	其余配件 Component
—	R01-R42	C01-C57

Har5935 Series Flush Grid

MODULAR BELT

MODULAR BELT 5935 Series

P=19.05mm, T=8.7mm

OPEN AREA:16%

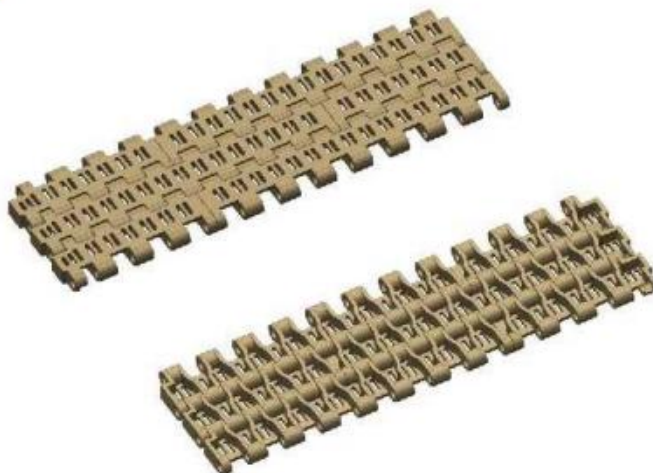

节距 Pitch	网链材质 Material	颜色 Color
19.05mm	POM	棕色/Brown 蓝色/Blue 白色/White
19.05mm	PP	白色/White

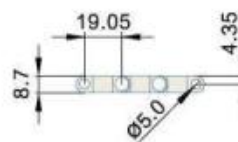
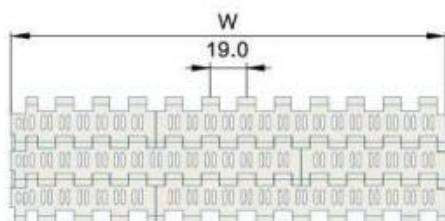

挡板高度 Cleat Height	10/50mm	材质 Material	重量 Weight(KG/SQ)	工作负荷 Working Capacity(N/M)
裙边高度 Side Apron Height	50mm	POM	6.0	13000
穿销材质 Pin Material	PP/NYLON/PBT DIAMETER:4.6mm	PP	4.6	7000
可选宽度 Available Width 塑料缩水率引致的正常误差; 正负差距 ±3(mm) The normal error caused by the shrinkage of plastic; ±3(mm)				
单片宽度 (Bulk Pieces Width)		组合宽度 (Assemble Width)		
76mm	152mm	76mm*N		
非标宽度 Nonstandard Width		非标定制前请和本公司联系 PLS Contact Hairise Confirm Width Before Booking		

链轮 Sprocket	护栏 Guide	其余配件 Component
S51	R01-R42	C01-C57

Har5935 Series Perforated Top MODULAR BELT

MODULAR BELT 5935 Series
P=19.05mm, T=8.7mm
OPEN AREA:6%



节距 Pitch	网链材质 Material	颜色 Color
19.05mm	POM	棕色/Brown

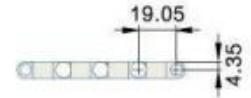
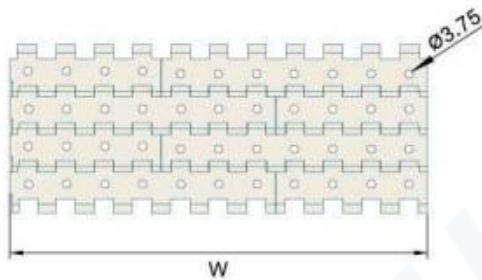

挡板高度 Cleat Height	10/50mm	材质 Material	重量 Weight(KG/SQ)	工作负荷 Working Capacity(N/M)
裙边高度 Side Apron Height	50mm	POM	6.5	13000
穿销材质 Pin Material	PP/NYLON/PBT DIAMETER:4.6mm	PP	5	7000
可选宽度 Available Width 塑料缩水率引致的正常误差; 正负差距 ±3(mm) The normal error caused by the shrinkage of plastic; ±3(mm)				
单片宽度 (Bulk Pieces Width)		组合宽度 (Assemble Width)		
76mm	152mm	76mm*N		
非标宽度 Nonstandard Width		非标定制前请和本公司联系 PLS Contact Hairise Confirm Width Before Booking		

链轮 Sprocket	护栏 Guide	其余配件 Component
S51	R01-R42	C01-C57

Har5935 Series Flat Top MODULAR BELT

MODULAR BELT 5935 Series
P=19.05mm, T=8.7mm
OPEN AREA:0%



节距 Pitch	网链材质 Material	颜色 Color
19.05mm	POM	棕色/Brown 白色/White
19.05mm	PP	白色/White

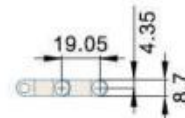
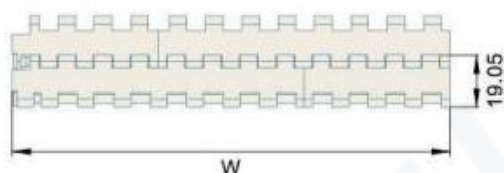

挡板高度 Cleat Height	10/50mm	材质 Material	重量 Weight(KG/SQ)	工作负荷 Working Capacity(N/M)
裙边高度 Side Apron Height	50mm	POM	6.72	13000
穿销材质 Pin Material	PP/NYLON/PBT DIAMETER:4.6mm	PP	5.3	7000
可选宽度 Available Width 塑料缩水率引致的正常误差: 正负差距 ±3(mm) The normal error caused by the shrinkage of plastic: ±3(mm)				
单片宽度 (Bulk Pieces Width)		组合宽度 (Assemble Width)		
76mm	152mm	76*N		
非标宽度 Nonstandard Width		非标定制前请和本公司联系 PLS Contact Hairise Confirm Width Before Booking		

链轮 Sprocket	护栏 Guide	其余配件 Component
S51	R01-R42	C01-C57

Har5935 Series Flush Grid Dynamic Transition MODULAR BELT

MODULAR BELT 5935 Series
P=19.05mm, T=8.7mm
OPEN AREA:16%

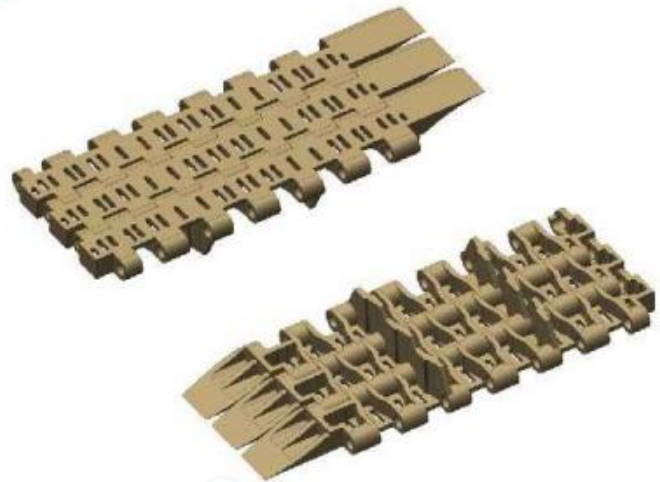

节距 Pitch	网链材质 Material	颜色 Color
19.05mm	POM	棕色/Brown

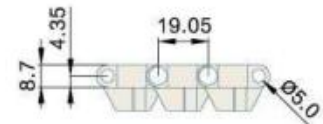
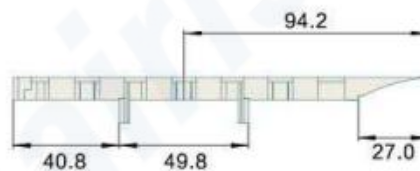
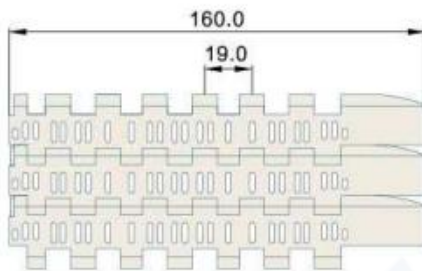

挡板高度 Cleat Height	—	材质 Material	重量 Weight(KG/M)	工作负荷 Working Capacity(N/M)
裙边高度 Side Apron Height	—	POM	1.04	2080
穿销材质 Pin Material	PP/NYLON/PBT DIAMETER:4.6mm	—	—	—

可选宽度 Available Width

塑料缩水率引致的正常误差；正负差距 ±3(mm) The normal error caused by the shrinkage of plastic; ±3(mm)

单片宽度 (Bulk Pieces Width)	组合宽度 (Assemble Width)
160mm	—
非标宽度 Nonstandard Width	非标定制前请和本公司联系 PLS Contact Hairise Confirm Width Before Booking

链轮 Sprocket	护栏 Guide	其余配件 Component
S51	R01-R42	C01-C57

Har5935 Series Flat Top MODULAR BELT

MODULAR BELT 5935 Series
P=19.05mm, T=8.7mm
OPEN AREA:0%

节距 Pitch	网链材质 Material	颜色 Color
19.05mm	POM	棕色/Brown
19.05mm	POM	白色/White
19.05mm	PP	白色/White



挡板

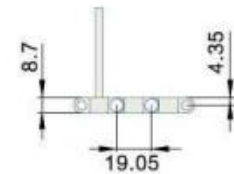
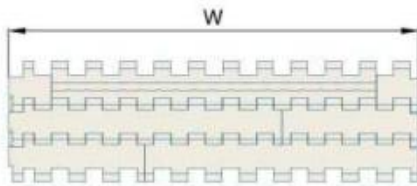

挡块

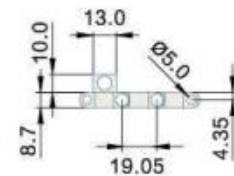
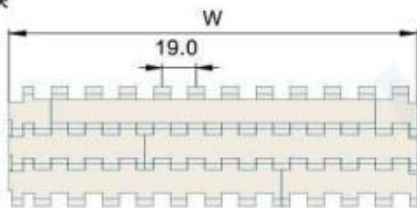

挡板高度 Cleat Height	10/50mm	材质 Material	POM	重量 Weight(KG/SQ)	6.72	工作负荷 Working Capacity(N/M)	13000
裙边高度 Side Apron Height	50mm						
穿销材质 Pin Material	PP/NYLON/PBT DIAMETER:4.6mm	PP		5.3		7000	

可选宽度 Available Width

塑料缩水率引致的正常误差; 正负差距 ±3(mm) The normal error caused by the shrinkage of plastic; ±3(mm)

单片宽度 (Bulk Pieces Width)		组合宽度 (Assemble Width)
76mm	152mm	76*N
非标宽度 Nonstandard Width		非标定制前请和本公司联系 PLS Contact Hairise Confirm Width Before Booking

链轮 Sprocket	护栏 Guide	其余配件 Component
S51	R01-R42	C01-C57

Har100 Series Flush Grid MODULAR BELT

MODULAR BELT 100 Series
P=25.4mm, T=8.7mm
OPEN AREA:31%

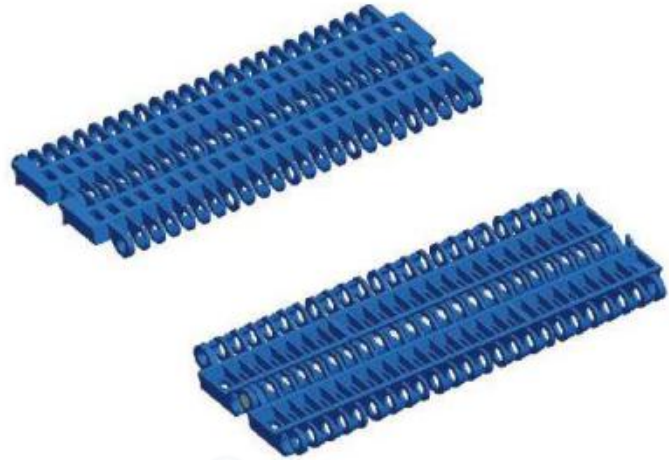

节距 Pitch	网链材质 Material	颜色 Color
25.4mm	POM	蓝色/Blue

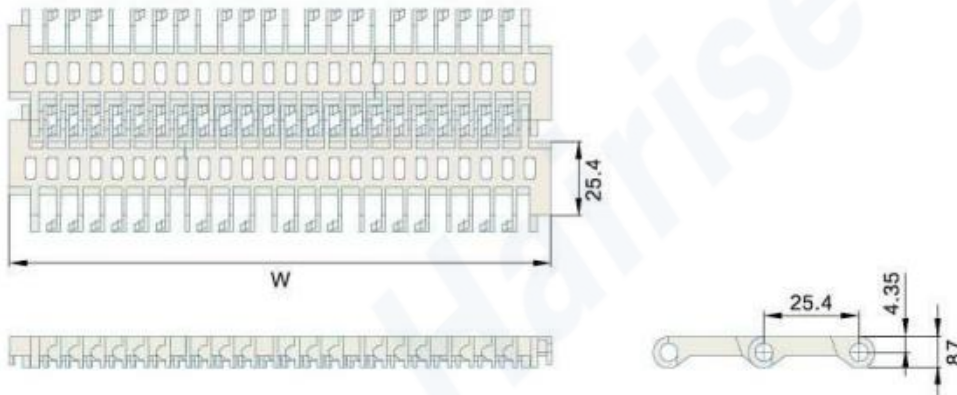

挡板高度 Cleat Height	—	材质 Material	重量 Weight(KG/SQ)	工作负荷 Working Capacity(N/M)
裙边高度 Side Apron Height	—	POM	3.9	9000
穿销材质 Pin Material	PP/NYLON/PBT DIAMETER:4.6mm	PP	—	—
可选宽度 Available Width 塑料缩水率引致的正常误差：正负差距±3(mm) The normal error caused by the shrinkage of plastic; ±3(mm)				
单片宽度 (Bulk Pieces Width)		组合宽度 (Assemble Width)		
50mm	158mm	107mm	50+107+158*N	
非标宽度 Nonstandard Width		非标定制前请和本公司联系 PLS Contact Hairise Confirm Width Before Booking		

链轮 Sprocket	护栏 Guide	其余配件 Component
S01	R01-R42	C01-C57

Har100 Series Raised Rib MODULAR BELT

MODULAR BELT 100 Series
P=25.4mm, T=14.3mm
OPEN AREA:31%



节距 Pitch	网链材质 Material	颜色 Color
25.4mm	POM	蓝色/Blue
		墨绿色/Dark Green

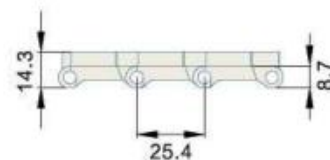
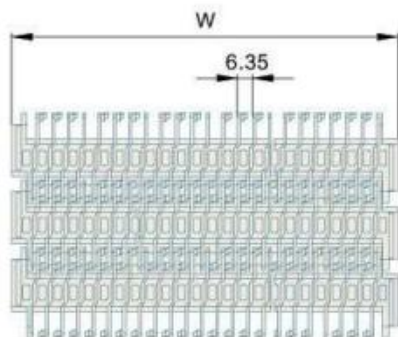

挡板高度 Cleat Height	—	材质 Material	重量 Weight(KG/SQ)	工作负荷 Working Capacity(N/M)
裙边高度 Side Apron Height	—	POM	5.86	8700
穿销材质 Pin Material	PP/NYLON/PBT DIAMETER:4.6mm	—	—	—
可选宽度 Available Width 塑料缩水率引致的正常误差; 正负差距 ±3(mm) The normal error caused by the shrinkage of plastic; ±3(mm)				
单片宽度 (Bulk Pieces Width)		组合宽度 (Assemble Width)		
50mm	158mm	107mm	50+107+158*N	
非标宽度 Nonstandard Width		非标定制前请和本公司联系 PLS Contact Hairise Confirm Width Before Booking		

链轮 Sprocket	护栏 Guide	其余配件 Component
S01	R01-R42	C01-C57

Har1000 Series Flat Top MODULAR BELT

MODULAR BELT 1000 Series
P=25.4mm, T=8.7mm
OPEN AREA:0%

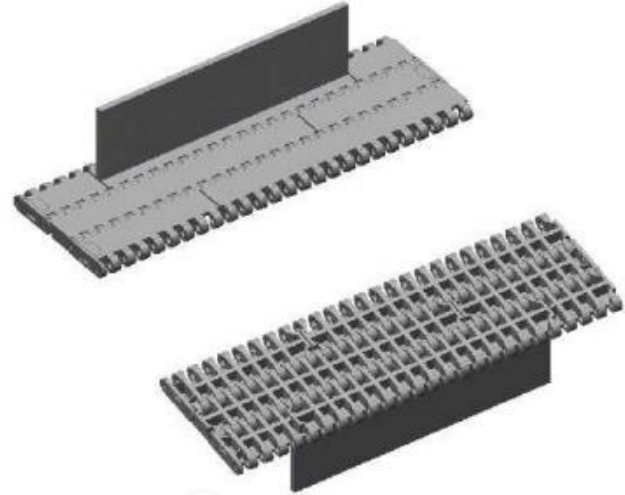

节距 Pitch	网链材质 Material	颜色 Color
25.4mm	POM	墨绿色/Dark Green

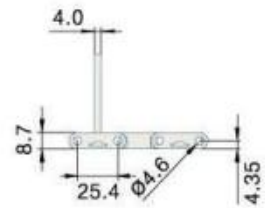
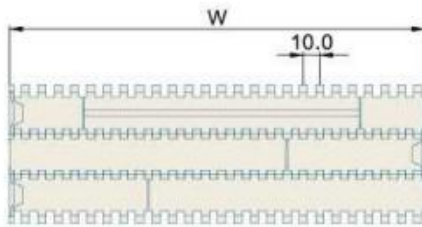

挡板高度 Cleat Height	50mm	材质 Material	重量 Weight(KG/SQ)	工作负荷 Working Capacity(N/M)
裙边高度 Side Apron Height	—	POM	6.49	21000
穿销材质 Pin Material	PP/NYLON/PBT DIAMETER:4.6mm	—	—	—
可选宽度 Available Width 塑料缩水率引致的正常误差：正负差距 ±3(mm) The normal error caused by the shrinkage of plastic; ±3(mm)				
单片宽度 (Bulk Pieces Width)		组合宽度 (Assemble Width)		
85mm	170mm	85*N		
非标宽度 Nonstandard Width		非标定制前请和本公司联系 PLS Contact Hairise Confirm Width Before Booking		

链轮 Sprocket	护栏 Guide	其余配件 Component
S24-S25	R01-R42	C01-C57

Har1000 Series Flat Top With Positrack MODULAR BELT

MODULAR BELT 1000 Series
 P=25.4mm, T=8.7mm
 OPEN AREA:0%



节距 Pitch	网链材质 Material	颜色 Color
25.4mm	POM	墨绿色/Dark Green

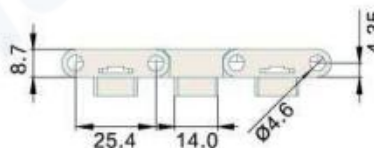
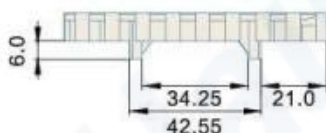
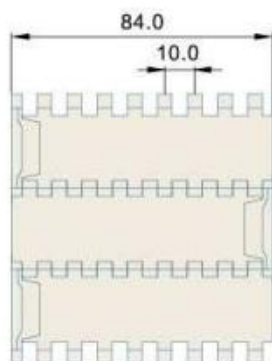

挡板高度 Cleat Height	—	材质 Material	重量 Weight(KG/SQ)	工作负荷 Working Capacity(N/M)
裙边高度 Side Apron Height	—	POM	6.49	1848
穿销材质 Pin Material	PP/NYLON/PBT DIAMETER:4.6mm	PP	4.6	11000

可选宽度 Available Width

塑料缩水率引致的正常误差; 正负差距 ±3(mm) The normal error caused by the shrinkage of plastic; ±3(mm)

单片宽度 (Bulk Pieces Width)	组合宽度 (Assemble Width)
84mm	84mm
非标宽度 Nonstandard Width	非标定制前请和本公司联系 PLS Contact Hairise Confirm Width Before Booking

链轮 Sprocket	护栏 Guide	其余配件 Component
S24-S25	R01-R42	C01-C57

Har1000 Series Flush Grid MODULAR BELT

MODULAR BELT 1000 Series
P=25.4mm, T=8.7mm
OPEN AREA:38%

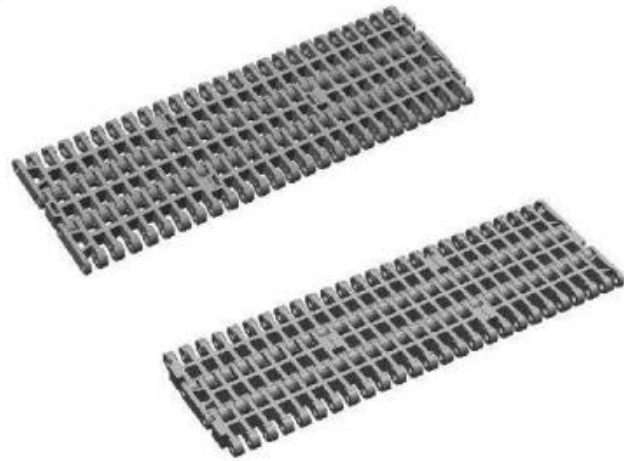

节距 Pitch	网链材质 Material	颜色 Color
25.4mm	POM	墨绿色/Dark Green

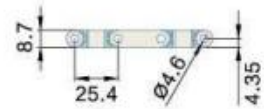
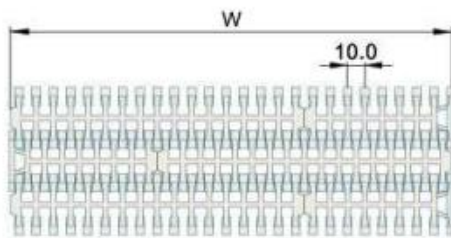

挡板高度 Cleat Height	50mm	材质 Material	重量 Weight(KG/SQ)	工作负荷 Working Capacity(N/M)
裙边高度 Side Apron Height	—	POM	5.42	21000
穿销材质 Pin Material	PP/NYLON/PBT DIAMETER:4.6mm	—	—	—
可选宽度 Available Width 塑料缩水率引致的正常误差：正负差距±3(mm) The normal error caused by the shrinkage of plastic; ±3(mm)				
单片宽度 (Bulk Pieces Width)		组合宽度 (Assemble Width)		
85mm	170mm	85*N		
非标宽度 Nonstandard Width		非标定制前请和本公司联系 PLS Contact Hairise Confirm Width Before Booking		

链轮 Sprocket	护栏 Guide	其余配件 Component
S24-S25	R01-R42	C01-C57

Har1000 Series Flush Grid With Positrack MODULAR BELT

MODULAR BELT 1000 Series
P=25.4mm, T=8.7mm
OPEN AREA:40%



节距 Pitch	网链材质 Material	颜色 Color
25.4mm	POM	墨绿/Dark Green

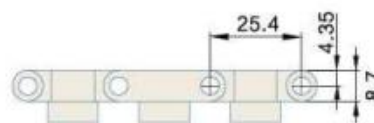
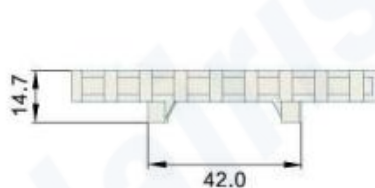

挡板高度 Cleat Height	—	材质 Material	重量 Weight(KG/SQ)	工作负荷 Working Capacity(N/M)
裙边高度 Side Apron Height	—	POM	5.6	1868
穿销材质 Pin Material	PP/NYLON/PBT DIAMETER:4.6mm	—	—	—
可选宽度 Available Width 塑料缩水率引致的正常误差; 正负差距 ±3(mm) The normal error caused by the shrinkage of plastic; ±3(mm)				
单片宽度 (Bulk Pieces Width)		组合宽度 (Assemble Width)		
85mm		85mm		
非标宽度 Nonstandard Width		非标定制前请和本公司联系 PLS Contact Hairise Confirm Width Before Booking		

链轮 Sprocket	护栏 Guide	其余配件 Component
S24-S25	R01-R42	C01-C57

Har1000 Series Flat Top With Positrack

MODULAR BELT

MODULAR BELT 1000 Series
 P=25.4mm, T=8.7mm
 OPEN AREA:0%

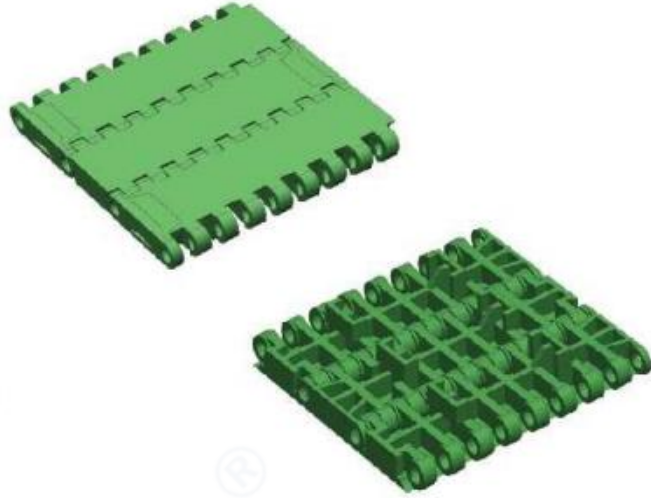

节距 Pitch	网链材质 Material	颜色 Color
25.4mm	POM	墨绿/Dark Green

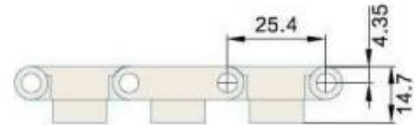
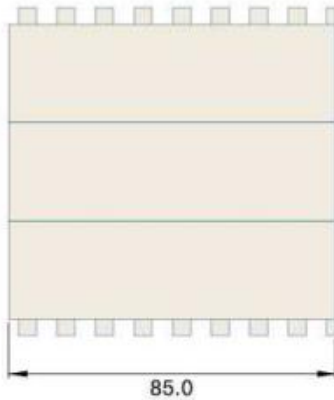

挡板高度 Cleat Height	—	材质 Material	重量 Weight(KG/SQ)	工作负荷 Working Capacity(N/M)
裙边高度 Side Apron Height	—	POM	6.8	1868
穿销材质 Pin Material	PP/NYLON/PBT DIAMETER:4.6mm	—	—	—
可选宽度 Available Width 塑料缩水率引致的正常误差：正负差距 ±3(mm) The normal error caused by the shrinkage of plastic; ±3(mm)				
单片宽度 (Bulk Pieces Width)		组合宽度 (Assemble Width)		
85mm		85mm		
非标宽度 Nonstandard Width		非标定制前请和本公司联系 PLS Contact Hairise Confirm Width Before Booking		

链轮 Sprocket	护栏 Guide	其余配件 Component
S24-S25	R01-R42	C01-C57

Har1000 Series Rubber Top MODULAR BELT

MODULAR BELT 1000 Series
P=25.4mm, T=13.2mm
OPEN AREA:0%

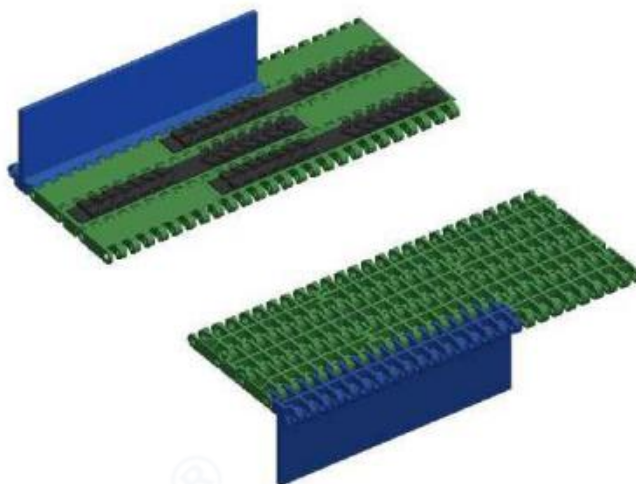

节距 Pitch	网链材质 Material	颜色 Color
25.4mm	PP	绿底黑胶/ Gree Plate Black Rubber

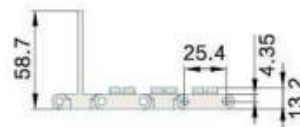
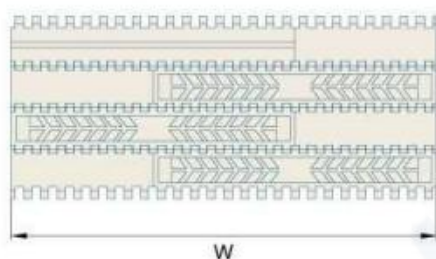

挡板高度 Cleat Height	50mm	材质 Material	重量 Weight(KG/SQ)	工作负荷 Working Capacity(N/M)
裙边高度 Side Apron Height	—	POM	6.5	11000
穿销材质 Pin Material	PP/NYLON/PBT DIAMETER:4.6mm	—	—	—
可选宽度 Available Width 塑料缩水率引致的正常误差; 正负差距 ±3(mm) The normal error caused by the shrinkage of plastic; ±3(mm)				
单片宽度 (Bulk Pieces Width)		组合宽度 (Assemble Width)		
170mm		85*N		
非标宽度 Nonstandard Width		非标定制前请和本公司联系 PLS Contact Hairise Confirm Width Before Booking		

链轮 Sprocket	护栏 Guide	其余配件 Component
S24-S25	R01-R42	C01-C57

Har1000 Series Raised Rib MODULAR BELT

MODULAR BELT 1000 Series
P=25.4mm, T=14.5/20.3mm
OPEN AREA:40%

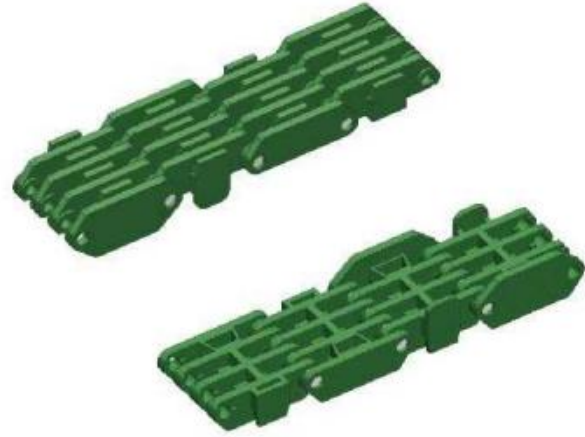

节距 Pitch	网链材质 Material	颜色 Color
25.4mm	POM	墨绿/Dark Green

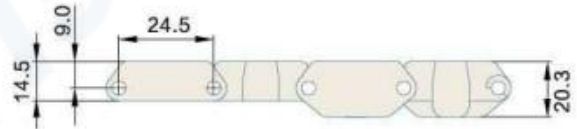

挡板高度 Cleat Height	—	材质 Material	重量 Weight(KG/M)	工作负荷 Working Capacity(N/M)
裙边高度 Side Apron Height	—	POM (38mm width)	0.4	400
穿销材质 Pin Material	PP/NYLON/PBT DIAMETER:4.6mm	POM (48mm width)	—	—
可选宽度 Available Width 塑料缩水率引致的正常误差：正负差距±3(mm) The normal error caused by the shrinkage of plastic; ±3(mm)				
单片宽度 (Bulk Pieces Width)		组合宽度 (Assemble Width)		
38mm		38mm		
非标宽度 Nonstandard Width		非标定制前请和本公司联系 PLS Contact Hairise Confirm Width Before Booking		

链轮 Sprocket	护栏 Guide	其余配件 Component
S24-S25	R01-R42	C01-C57

Har1000 Series Flat Top With Positrack MODULAR BELT

MODULAR BELT 1000 Series
P=25.4mm, T=8.7mm
OPEN AREA:0%

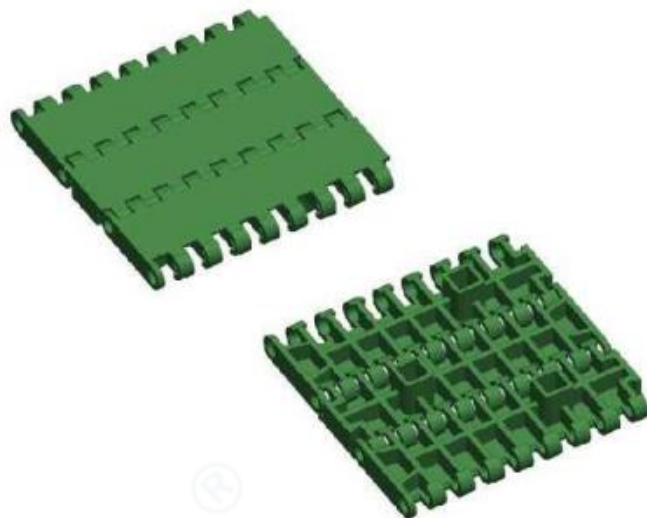

节距 Pitch	网链材质 Material	颜色 Color
25.4mm	POM	墨绿色/Dark Green

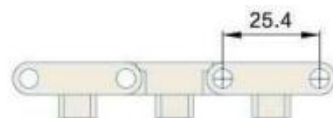
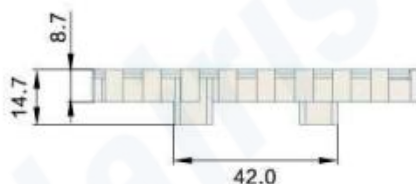
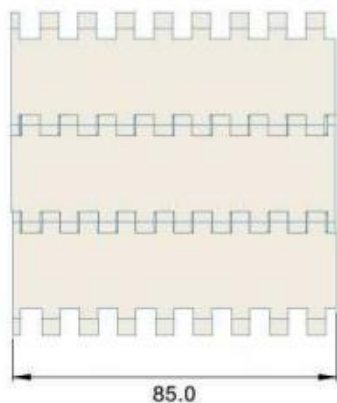

挡板高度 Cleat Height	50mm	材质 Material	重量 Weight(KG/SQ)	工作负荷 Working Capacity(N/M)
裙边高度 Side Apron Height	—	POM	7.0	22000
穿销材质 Pin Material	PP/NYLON/PBT	—	—	—

可选宽度 Available Width

塑料缩水率引致的正常误差：正负差距 ±3(mm) The normal error caused by the shrinkage of plastic; ±3(mm)

单片宽度 (Bulk Pieces Width)	组合宽度 (Assemble Width)
85mm	85
非标宽度 Nonstandard Width	非标定制前请和本公司联系 PLS Contact Hairise Confirm Width Before Booking

链轮 Sprocket	护栏 Guide	其余配件 Component
S24-S25	R01-R42	C01-C57

Har1000 Series Raised Rib MODULAR BELT

MODULAR BELT 1000 Series
P=25.4mm, T=14.3mm
OPEN AREA:38%



节距 Pitch	网链材质 Material	颜色 Color
25.4mm	POM	墨绿色/Dark Green

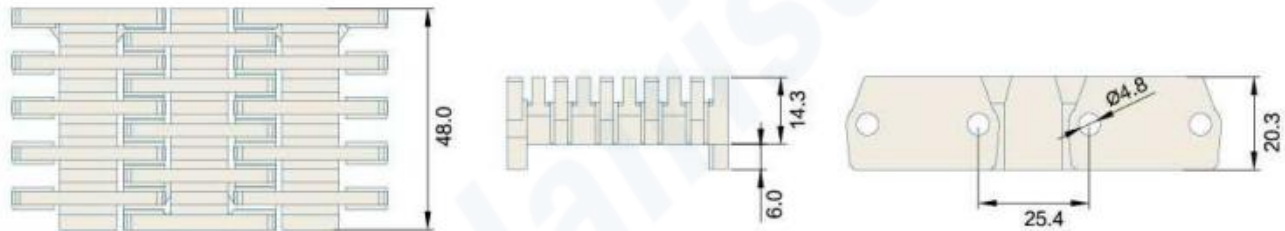

挡板高度 Cleat Height	—	材质 Material	重量 Weight(KG/M)	工作负荷 Working Capacity(N/M)
裙边高度 Side Apron Height	—	POM	0.5	500
穿销材质 Pin Material	PP/NYLON/PBT DIAMETER:4.6mm	—	—	—
可选宽度 Available Width 塑料缩水率引致的正常误差：正负差距±3(mm) The normal error caused by the shrinkage of plastic; ±3(mm)				
单片宽度 (Bulk Pieces Width)		组合宽度 (Assemble Width)		
48mm		48mm		
非标宽度 Nonstandard Width		非标定制前请和本公司联系 PLS Contact Hairise Confirm Width Before Booking		

链轮 Sprocket	护栏 Guide	其余配件 Component
S24-S25	R01-R42	C01-C57

Har1000 Series Raised Rib MODULAR BELT

MODULAR BELT 1000 Series
P=25.4mm, T=14.3mm
OPEN AREA:40%

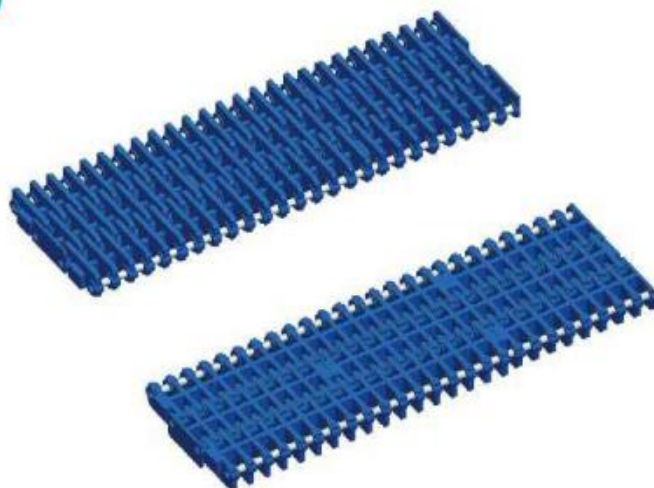

节距 Pitch	网链材质 Material	颜色 Color
25.4mm	POM	墨绿/Dark Green

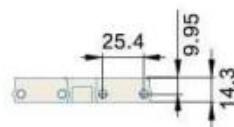
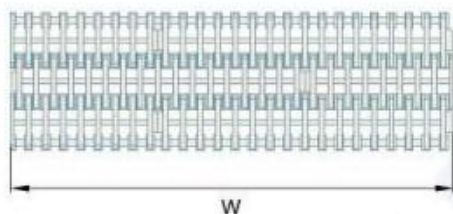

挡板高度 Cleat Height	50mm	材质 Material	POM	重量 Weight(KG/SQ)	8.2	工作负荷 Working Capacity(N/M)	22000
裙边高度 Side Apron Height	—						
穿销材质 Pin Material	PP/NYLON/PBT DIAMETER:4.6mm	—	—	—	—	—	—
可选宽度 Available Width 塑料缩水率引致的正常误差; 正负差距 ±3(mm) The normal error caused by the shrinkage of plastic; ±3(mm)							
单片宽度 (Bulk Pieces Width)		组合宽度 (Assemble Width)					
85mm	170mm	85*N					
非标宽度 Nonstandard Width		非标定制前请和本公司联系 PLS Contact Hairise Confirm Width Before Booking					

链轮 Sprocket	护栏 Guide	其余配件 Component
S24-S25	R01-R42	C01-C57

Har1001 Series Flat Top MODULAR BELT

MODULAR BELT 1001 Series
P=27.2mm, T=10mm
OPEN AREA:0%

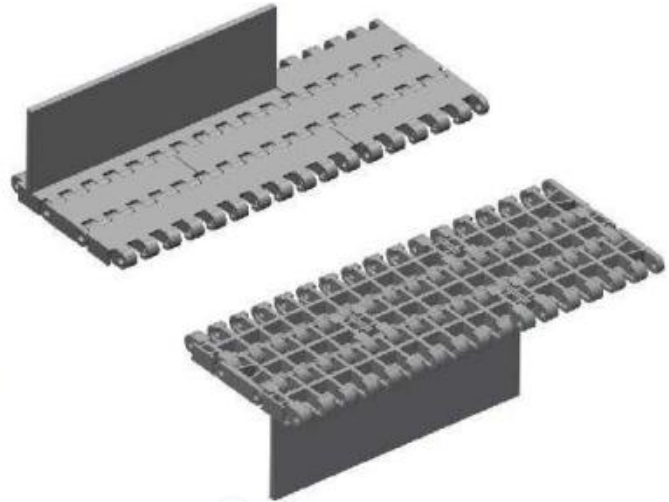

节距 Pitch	网链材质 Material	颜色 Color
27.2mm	POM	白色/White

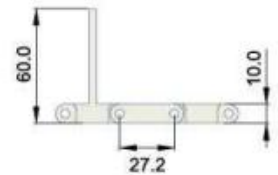
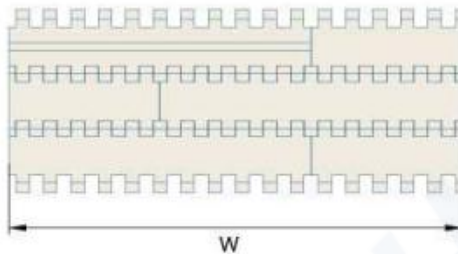

挡板高度 Cleat Height	50mm	材质 Material	重量 Weight(KG/SQ)	工作负荷 Working Capacity(N/M)
裙边高度 Side Apron Height	—	POM	8.5	22000
穿销材质 Pin Material	PP/Nylon/PBT	—	—	—
可选宽度 Available Width 塑料缩水率引致的正常误差：正负差距 ±3(mm) The normal error caused by the shrinkage of plastic; ±3(mm)				
单片宽度 (Bulk Pieces Width)		组合宽度 (Assemble Width)		
76mm	152mm	76mm*N		
非标宽度 Nonstandard Width		非标定制前请和本公司联系 PLS Contact Hairise Confirm Width Before Booking		

链轮 Sprocket	护栏 Guide	其余配件 Component
—	R01-R42	C01-C57

Har1005 Series Flat Top With Positrack MODULAR BELT

MODULAR BELT 1005 Series
P=25.4mm, T=12.7mm
OPEN AREA:0%



节距 Pitch	网链材质 Material	颜色 Color
25.4mm	POM	墨绿色/Dark Green

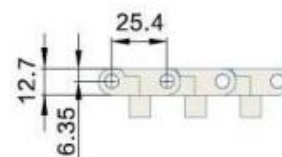
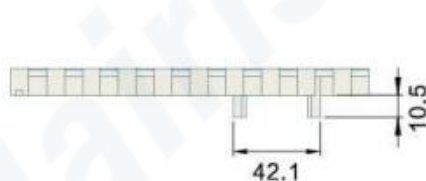
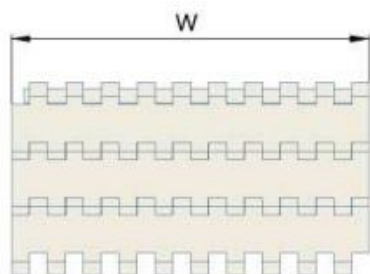

挡板高度 Cleat Height	—	材质 Material	重量 Weight(KG/SQ)	工作负荷 Working Capacity(N/M)
裙边高度 Side Apron Height	—	POM	13.5	35000
穿销材质 Pin Material	PP/NYLON/PBT DIAMETER:6mm	PP	9.0	17500

可选宽度 Available Width

塑料缩水率引致的正常误差; 正负差距 ±3(mm) The normal error caused by the shrinkage of plastic; ±3(mm)

单片宽度 (Bulk Pieces Width)		组合宽度 (Assemble Width)
85mm	170mm	85*N
非标宽度 Nonstandard Width		非标定制前请和本公司联系 PLS Contact Hairise Confirm Width Before Booking

链轮 Sprocket	护栏 Guide	其余配件 Component
S25-S26	R01-R42	C01-C57

Har1005 Series Roller Top MODULAR BELT

MODULAR BELT 1005 Series
P=25.4mm, T=27.2mm
OPEN AREA:0%

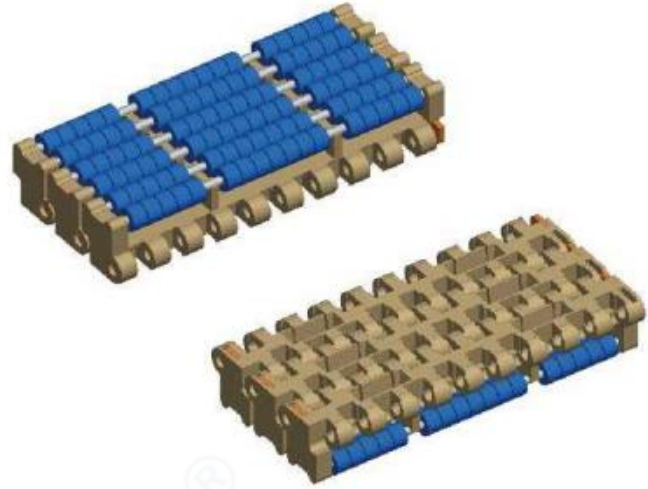

节距 Pitch	网链材质 Material	颜色 Color
25.4mm	POM	咖啡底蓝珠/ Brown Plate Blue Roller

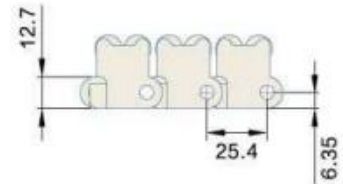
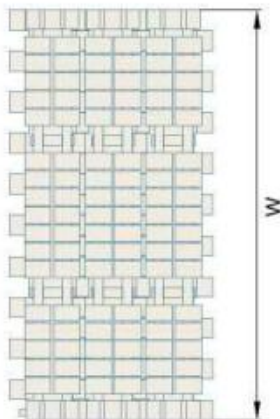

挡板高度 Cleat Height	—	材质 Material	重量 Weight(KG/SQ)	工作负荷 Working Capacity(N/M)
裙边高度 Side Apron Height	—	POM	31.11	38000
穿销材质 Pin Material	PP/NYLON/PBT DIAMETER:6mm	—	—	—
可选宽度 Available Width 塑料缩水率引致的正常误差：正负差距 ±3(mm) The normal error caused by the shrinkage of plastic; ±3(mm)				
单片宽度 (Bulk Pieces Width)		组合宽度 (Assemble Width)		
85mm	170mm	85*N		
非标宽度 Nonstandard Width		非标定制前请和本公司联系 PLS Contact Hairise Confirm Width Before Booking		

链轮 Sprocket	护栏 Guide	其余配件 Component
S25-S26	R01-R42	C01-C57

Har1005 Series Rubber Top MODULAR BELT

MODULAR BELT 1005 Series
P=25.4mm, T=15.2mm
OPEN AREA:0%

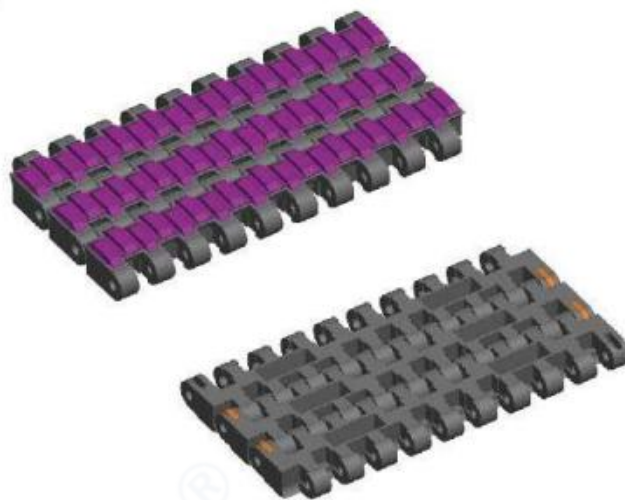

节距 Pitch	网链材质 Material	颜色 Color
25.4mm	PP	深灰色紫胶/Dark Grey Plate Purple Rubber

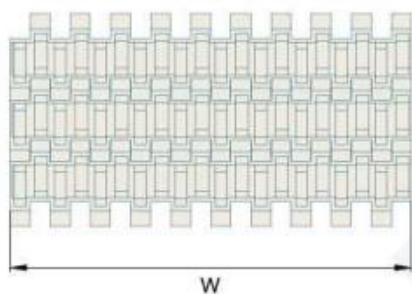

挡板高度 Cleat Height	—	材质 Material	重量 Weight(KG/SQ)	工作负荷 Working Capacity(N/M)
裙边高度 Side Apron Height	—	PP	10.0	17500
穿销材质 Pin Material	PP/NYLON/PBT DIAMETER:4.6mm	—	—	—
可选宽度 Available Width 塑料缩水率引致的正常误差：正负差距 ±3(mm) The normal error caused by the shrinkage of plastic; ±3(mm)				
单片宽度 (Bulk Pieces Width)		组合宽度 (Assemble Width)		
85mm	170mm	85mm*N		
非标宽度 Nonstandard Width		非标定制前请和本公司联系 PLS Contact Hairise Confirm Width Before Booking		

链轮 Sprocket	护栏 Guide	其余配件 Component
S25-S26	R01-R42	C01-C57

Har1005 Series Flat Top Dynamic Transition With Positioners

MODULAR BELT

MODULAR BELT 1005 Series
 P=25.4mm, T=12.7mm
 OPEN AREA:0%

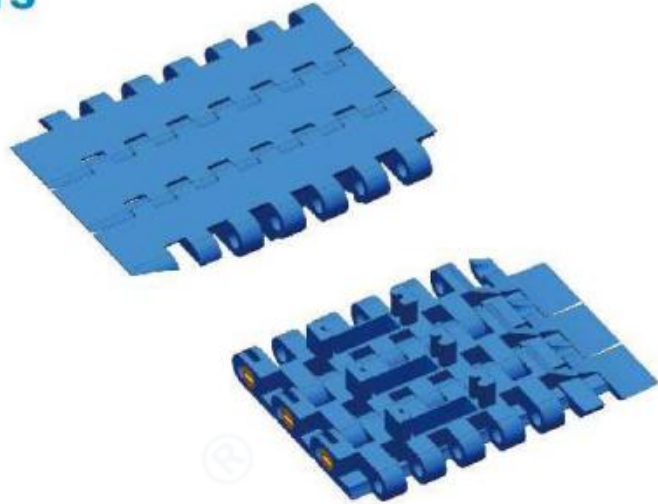

节距 Pitch	网链材质 Material	颜色 Color
25.4mm	POM	蓝色/Blue

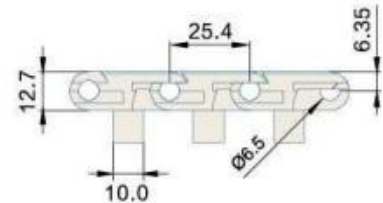
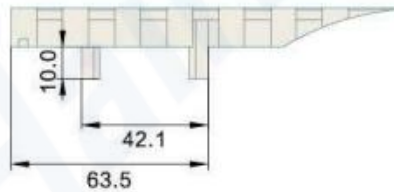
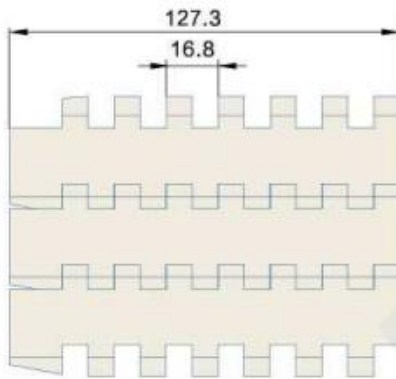

挡板高度 Cleat Height	—	材质 Material	重量 Weight(KG/SQ)	工作负荷 Working Capacity(N/M)
裙边高度 Side Apron Height	—	POM	13.5	35000
穿销材质 Pin Material	PP/NYLON/PBT DIAMETER:4.6mm	—	—	—
可选宽度 Available Width 塑料缩水率引致的正常误差：正负差距 ±3(mm) The normal error caused by the shrinkage of plastic; ±3(mm)				
单片宽度 (Bulk Pieces Width)		组合宽度 (Assemble Width)		
127.3mm		127.3mm		
非标宽度 Nonstandard Width		非标定制前请和本公司联系 PLS Contact Hairise Confirm Width Before Booking		

链轮 Sprocket	护栏 Guide	其余配件 Component
S25-S26	R01-R42	C01-C57

Har2400 Series Flush Grid

MODULAR BELT

MODULAR BELT 2400 Series

P=25.4mm, T=13mm

OPEN AREA:42%

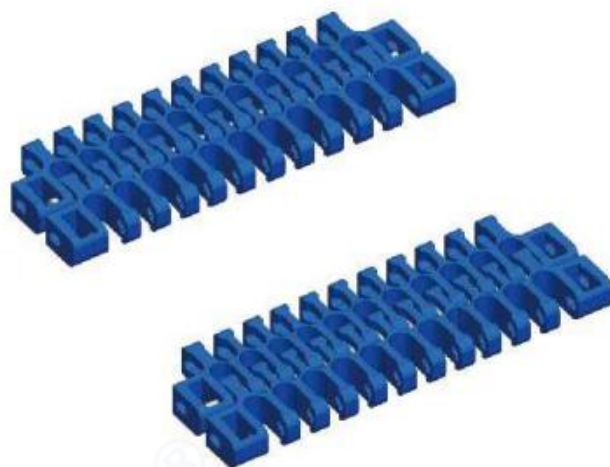

节距 Pitch	网链材质 Material	颜色 Color	转弯系数 Turn Radius
25.4mm	POM	蓝色/Blue 白色/White	2.5
	PP	蓝色/Blue	2.5



挡板高度 Cleat Height	50mm	材质 Material	重量 Weight(KG/SQ)	工作负荷 Working Capacity(N/M)
裙边高度 Side Apron Height	50mm	POM	8.44	17300
穿销材质 Pin Material	PP/NYLON/PBT DIAMETER:4.5mm	PP	5.47	11200

可选宽度 Available Width

塑料缩水率引致的正常误差：正负差距±3(mm) The normal error caused by the shrinkage of plastic: ±3(mm)

单片宽度 (Bulk Pieces Width)	组合宽度 (Assemble Width)
250mm	—
非标宽度 Nonstandard Width	非标定制前请和本公司联系 PLS Contact Hairise Confirm Width Before Booking

链轮 Sprocket	护栏 Guide	其余配件 Component
S44-S45	R01-R42	C01-C57

Har2400 Series Flush Grid With Corner Track

MODULAR BELT

MODULAR BELT 2400 Series

P=25.4mm, T=13mm

OPEN AREA:42%



节距 Pitch	网链材质 Material	颜色 Color	转弯系数 Turn Radius
25.4mm	POM	白色/White 蓝色/Blue	2.5
25.4mm	PP	白色/White	2.5

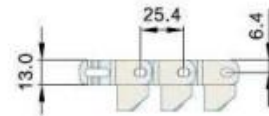
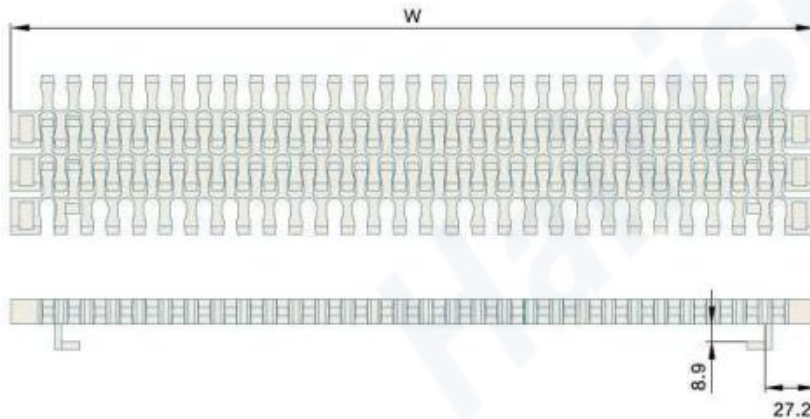

挡板高度 Cleat Height	50mm	材质 Material	重量 Weight(KG/SQ)	工作负荷 Working Capacity(N/M)
裙边高度 Side Apron Height	50mm	POM	8.7	26000
穿销材质 Pin Material	PP/NYLON/PBT DIAMETER:4.5mm	PP	6.0	15000

可选宽度 Available Width

塑料缩水率引起的正常误差：正负差距 ±3(mm) The normal error caused by the shrinkage of plastic: ±3(mm)

单片宽度 (Bulk Pieces Width)	组合宽度 (Assemble Width)
250mm	—
非标宽度 Nonstandard Width	非标定制前请和本公司联系 PLS Contact Hairise Confirm Width Before Booking

链轮 Sprocket	护栏 Guide	其余配件 Component
S44-S45	R01-R42	C01-C57

Har2400H Series Raised Rib MODULAR BELT

MODULAR BELT 2400H Series

P=25.4mm, T=22.8mm

OPEN AREA:42%

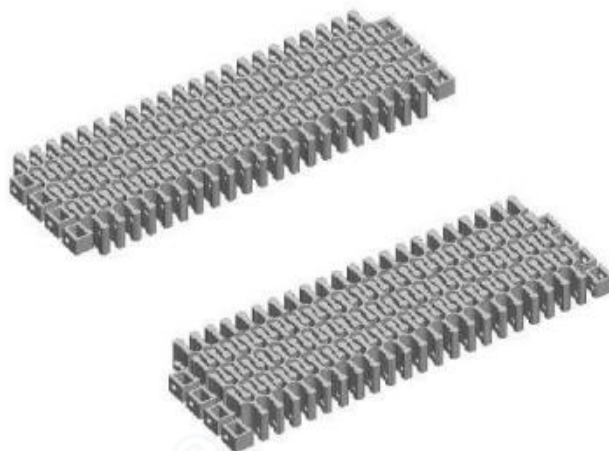

节距 Pitch	网链材质 Material	颜色 Color	转弯系数 Turn Radius
25.4mm	POM	白色/White	2.5

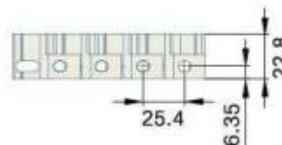
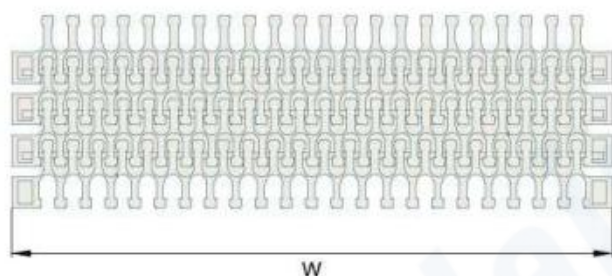

挡板高度 Cleat Height	50mm	材质 Material	POM	重量 Weight(KG/SQ)	13.82	工作负荷 Working Capacity(N/M)	26000
裙边高度 Side Apron Height	50mm						
穿销材质 Pin Material	PP/NYLON/PBT DIAMETER:4.5mm	PP		9.28		15000	

可选宽度 Available Width

塑料缩水率引致的正常误差：正负差距 ±3(mm) The normal error caused by the shrinkage of plastic: ±3(mm)

单片宽度 (Bulk Pieces Width)	组合宽度 (Assemble Width)
249mm	—
非标宽度 Nonstandard Width	非标定制前请和本公司联系 PLS Contact Hairise Confirm Width Before Booking

链轮 Sprocket	护栏 Guide	其余配件 Component
S44-S45	R01-R42	C01-C57

Har2401 Series Flush Grid MODULAR BELT

MODULAR BELT 2401 Series
P=25.4mm, T=11mm
OPEN AREA:35%



节距 Pitch	网链材质 Material	颜色 Color	转弯系数 Turn Radius
25.4mm	POM	白色/White 蓝色/Blue	2.5
	PP	白色/White	



挡板高度 Cleat Height	10mm	材质 Material	重量 Weight(KG/SQ)	工作负荷 Working Capacity(N/M)
裙边高度 Side Apron Height	—	POM	7.3	26000
穿销材质 Pin Material	PP/NYLON/PBT	PP	5.0	19000
可选宽度 Available Width 塑料缩水率引致的正常误差: 正负差距 ±3(mm) The normal error caused by the shrinkage of plastic; ±3(mm)				
单片宽度 (Bulk Pieces Width)			组合宽度 (Assemble Width)	
70mm	200mm	120mm	70+120+12*N	
非标宽度 Nonstandard Width			非标定制前请和本公司联系 PLS Contact Hairise Confirm Width Before Booking	

链轮 Sprocket	护栏 Guide	其余配件 Component
S45	R01-R42	C01-C57

Har2546 Series Flush Grid

MODULAR BELT

MODULAR BELT 2546 Series

P=38.1mm, T=18mm

OPEN AREA:31%

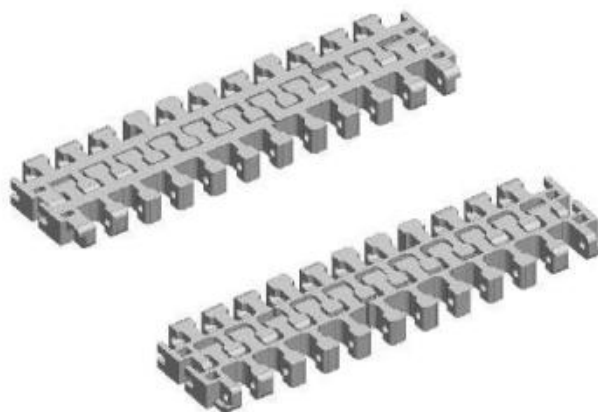

节距 Pitch	网链材质 Material	颜色 Color	转弯系数 Turn Radius
38.1mm	PP	白色/White	2.5

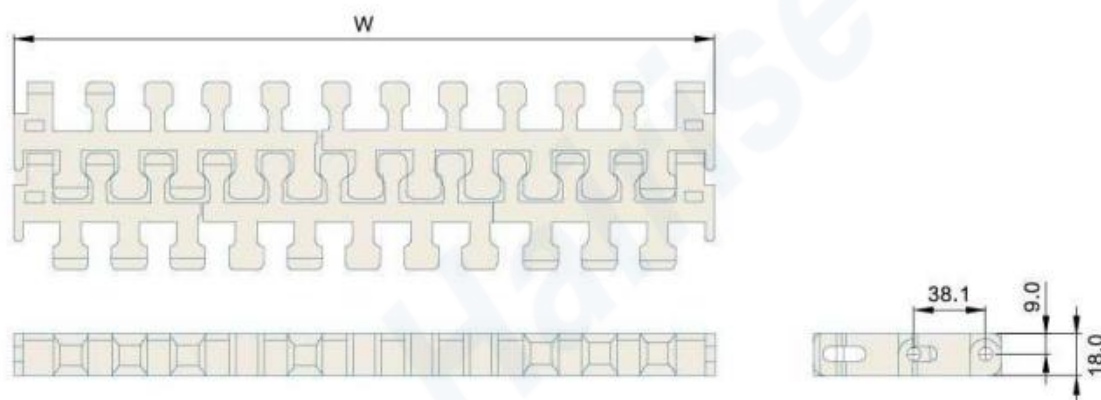

挡板高度 Cleat Height	—	材质 Material	PP	重量 Weight(KG/SQ)	8.0	工作负荷 Working Capacity(N/M)	23000
裙边高度 Side Apron Height	—						
穿销材质 Pin Material	PP/NYLON/PBT DIAMETER:6.5mm	—	—	—	—	—	—
可选宽度 Available Width 塑料缩水率引致的正常误差：正负差距 ±3(mm) The normal error caused by the shrinkage of plastic: ±3(mm)							
单片宽度 (Bulk Pieces Width)				组合宽度 (Assemble Width)			
130.7mm				—			
非标宽度 Nonstandard Width				非标定制前请和本公司联系 PLS Contact Hairise Confirm Width Before Booking			

链轮 Sprocket	护栏 Guide	其余配件 Component
—	R01-R42	C01-C57

Har2545 Series Flush Grid MODULAR BELT

MODULAR BELT 2545 Series
P=25mm, T=12mm
OPEN AREA:32%

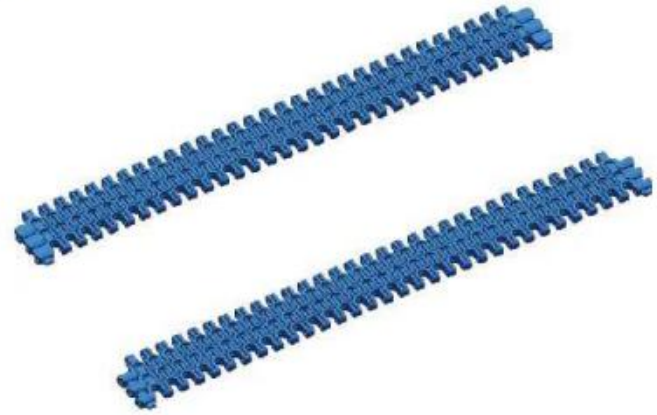

节距 Pitch	网链材质 Material	颜色 Color	转弯系数 Turn Radius
25.4mm	POM	白色/White	2.5

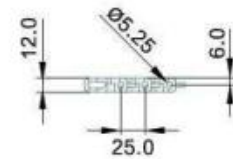
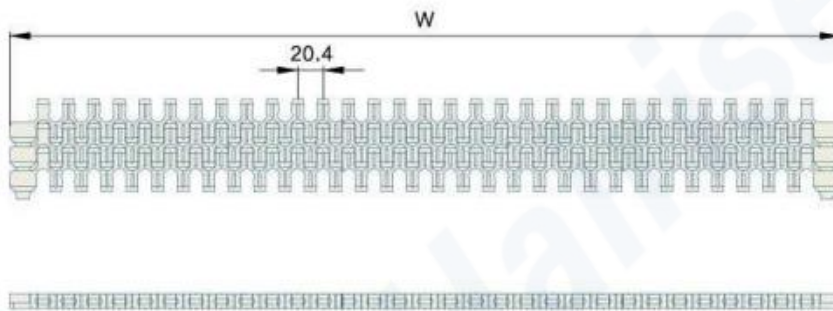

挡板高度 Cleat Height	—	材质 Material	重量 Weight(KG/SQ)	工作负荷 Working Capacity(N/M)
裙边高度 Side Apron Height	—	POM	7.0	25000
穿销材质 Pin Material	PP/NYLON/PBT DIAMETER:5mm	—	—	—
可选宽度 Available Width 塑料缩水率引致的正常误差：正负差距 ±3(mm) The normal error caused by the shrinkage of plastic; ±3(mm)				
单片宽度 (Bulk Pieces Width)		组合宽度 (Assemble Width)		
269mm		—		
非标宽度 Nonstandard Width		非标定制前请和本公司联系 PLS Contact Hairise Confirm Width Before Booking		

链轮 Sprocket	护栏 Guide	其余配件 Component
S49	R01-R42	C01-C57

Har2520 Series Flat Top MODULAR BELT

MODULAR BELT 2520 Series
P=25.4mm, T=10mm
OPEN AREA:0%



节距 Pitch	网链材质 Material	颜色 Color
25.4mm	POM	白色/White 蓝色/Blue
25.4mm	PP	白色/White 蓝色/Blue

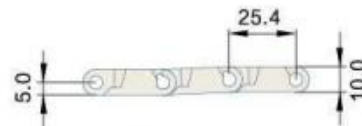
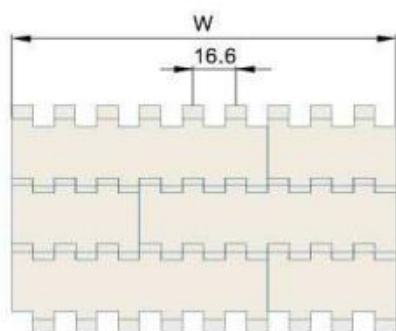

挡板高度 Cleat Height	50mm	材质 Material	重量 Weight(KG/SQ)	工作负荷 Working Capacity(N/M)
裙边高度 Side Apron Height	50mm	POM	8.4	21500
穿销材质 Pin Material	PP/NYLON/PBT DIAMETER:5mm	PP	5.5	18000

可选宽度 Available Width

塑料缩水率引致的正常误差：正负差距 ±3(mm) The normal error caused by the shrinkage of plastic: ±3(mm)

单片宽度 (Bulk Pieces Width)	组合宽度 (Assemble Width)
50mm	100mm
非标宽度 Nonstandard Width	100+50*N

非标定制前请和本公司联系
PLS Contact Hairise Confirm Width Before Booking

链轮 Sprocket	护栏 Guide	其余配件 Component
S46-S47	R01-R42	C01-C57

Har2520 Series Flush Grid MODULAR BELT

MODULAR BELT 2520 Series
P=25.4mm, T=10mm
OPEN AREA:36%



节距 Pitch	网链材质 Material	颜色 Color
25.4mm	POM	白色/White 蓝色/Blue
	PP	白色/White

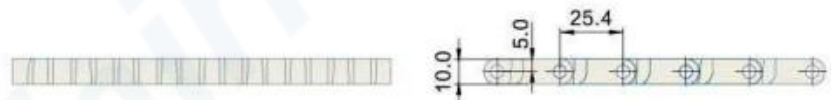
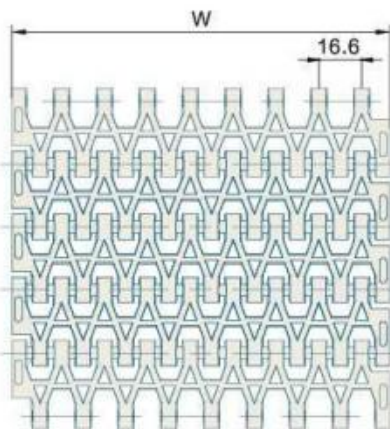

挡板高度 Cleat Height	50mm	材质 Material	重量 Weight(KG/SQ)	工作负荷 Working Capacity(N/M)
裙边高度 Side Apron Height	50mm	POM	7.0	17500
穿销材质 Pin Material	PP/NYLON/PBT DIAMETER:5mm	PP	4.6	15000
可选宽度 Available Width 塑料缩水率引致的正常误差: 正负差距 ±3(mm) The normal error caused by the shrinkage of plastic; ±3(mm)				
单片宽度 (Bulk Pieces Width)		组合宽度 (Assemble Width)		
50mm	100mm	50*N		
非标宽度 Nonstandard Width		非标定制前请和本公司联系 PLS Contact Hairise Confirm Width Before Booking		

链轮 Sprocket	护栏 Guide	其余配件 Component
S46-S47	R01-R42	C01-C57

Har2520 Series Rubber Top MODULAR BELT

MODULAR BELT 2520 Series
P=25.4mm, T=14mm
OPEN AREA:0%

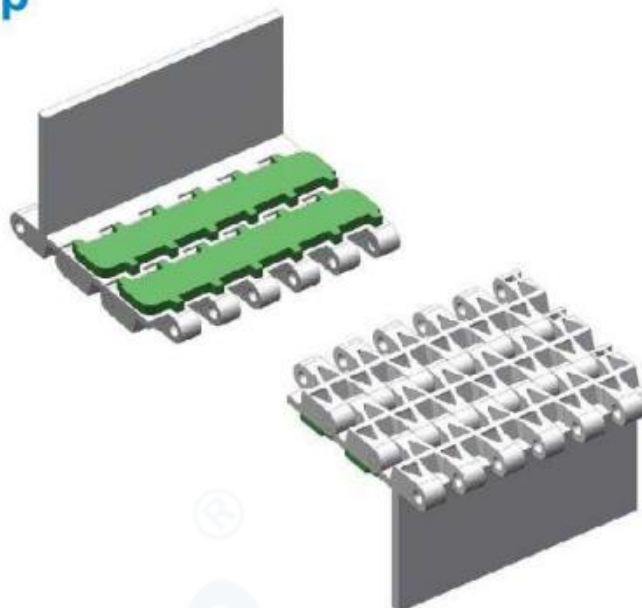

节距 Pitch	网链材质 Material	颜色 Color
25.4mm	PP	白底绿胶/ White Plate Green Rubber 白底灰胶/ White Plate Grey Rubber

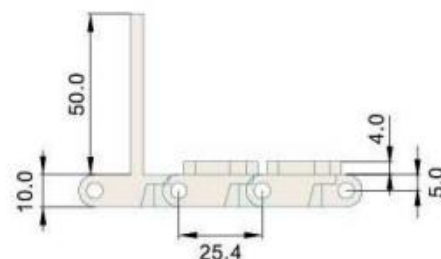
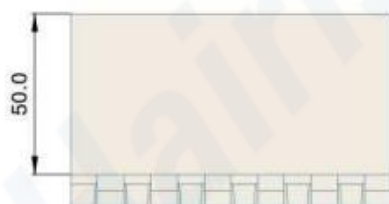
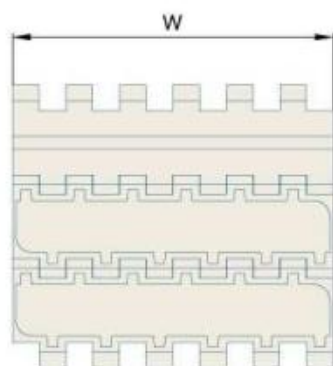

挡板高度 Cleat Height	50mm	材质 Material	重量 Weight(KG/SQ)	工作负荷 Working Capacity(N/M)
裙边高度 Side Apron Height	—	PP	8.7	14000
穿销材质 Pin Material	PP/NYLON/PBT DIAMETER:5mm	—	—	—
可选宽度 Available Width 塑料缩水率引致的正常误差：正负差距 ±3(mm) The normal error caused by the shrinkage of plastic: ±3(mm)				
单片宽度 (Bulk Pieces Width)		组合宽度 (Assemble Width)		
50mm	100mm	50*N		
非标宽度 Nonstandard Width		非标定制前请和本公司联系 PLS Contact Hairise Confirm Width Before Booking		

链轮 Sprocket	护栏 Guide	其余配件 Component
S46-S47	R01-R42	C01-C57

Har2541 Series Flush Grid MODULAR BELT

MODULAR BELT 2541 Series
P=25.4mm, T=9mm
OPEN AREA:29%

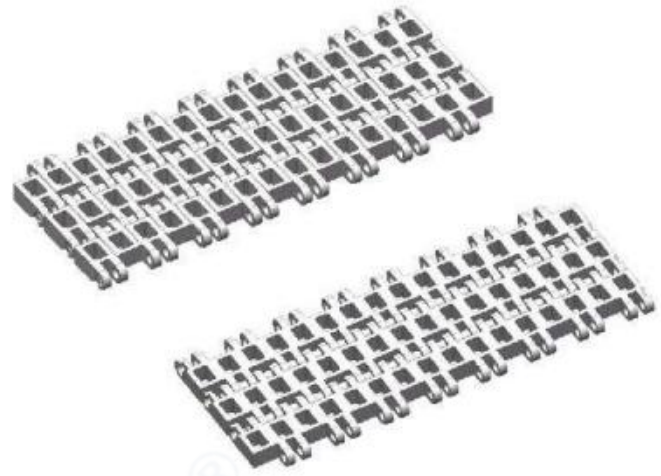

节距 Pitch	网链材质 Material	颜色 Color
25.4mm	POM	蓝色/Blue
25.4mm	POM	白色/White
25.4mm	PP	白色/White

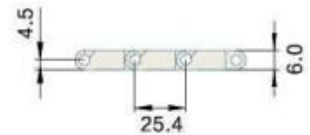
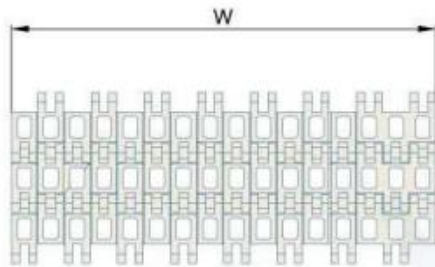

挡板高度 Cleat Height	—	材质 Material	重量 Weight(KG/SQ)	工作负荷 Working Capacity(N/M)
裙边高度 Side Apron Height	—	POM	7.0	—
穿销材质 Pin Material	PP/NYLON/PBT DIAMETER:5mm	PP	5.0	—
可选宽度 Available Width 塑料缩水率引致的正常误差：正负差距 ±3(mm) The normal error caused by the shrinkage of plastic: ±3(mm)				
单片宽度 (Bulk Pieces Width)		组合宽度 (Assemble Width)		
200mm		100*N		
非标宽度 Nonstandard Width		非标定制前请和本公司联系 PLS Contact Hairise Confirm Width Before Booking		

链轮 Sprocket	护栏 Guide	其余配件 Component
S48	R01-R42	C01-C57

Har2540 Series Flush Grid

MODULAR BELT

MODULAR BELT 2540 Series

P=25.4mm, T=12.7mm

OPEN AREA:40%

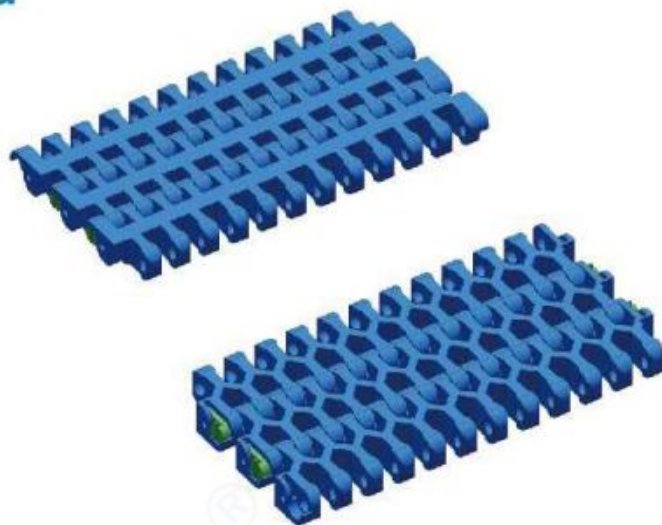

节距 Pitch	网链材质 Material	颜色 Color	转弯系数 Turn Radius
25.4mm	POM	蓝色/Blue	2.5

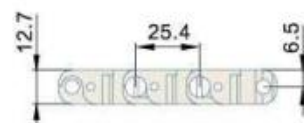
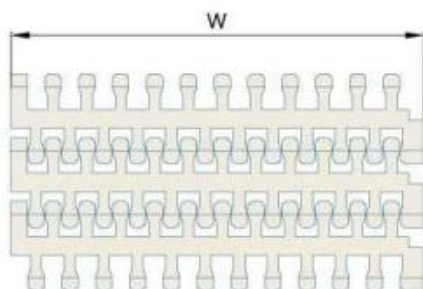

挡板高度 Cleat Height	—	材质 Material	重量 Weight(KG/SQ)	工作负荷 Working Capacity(N/M)
裙边高度 Side Apron Height	—	POM	8.0	23000
穿销材质 Pin Material	PP/NYLON/PBT DIAMETER:5mm	—	—	—
可选宽度 Available Width 塑料缩水率引致的正常误差: 正负差距 ±3(mm) The normal error caused by the shrinkage of plastic: ±3(mm)				
单片宽度 (Bulk Pieces Width)		组合宽度 (Assemble Width)		
152mm		76*N		
非标宽度 Nonstandard Width		非标定制前请和本公司联系 PLS Contact Hairise Confirm Width Before Booking		

链轮 Sprocket	护栏 Guide	其余配件 Component
S47	R01-R42	C01-C57

Har7100 Series Flush Grid MODULAR BELT

MODULAR BELT 7100 Series
P=25.4mm, T=12.7mm
OPEN AREA:28%

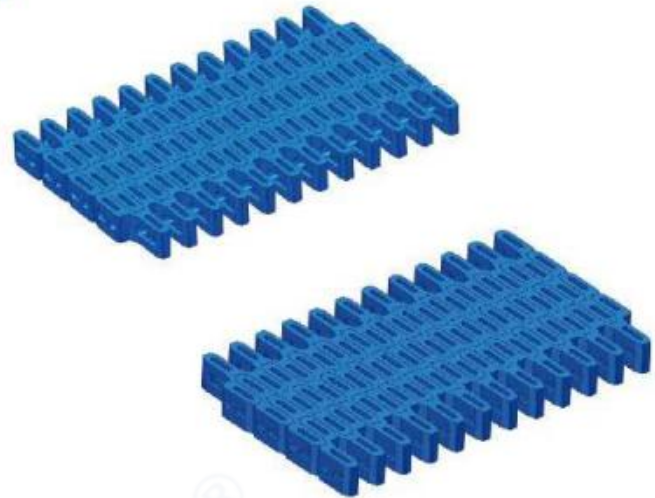

节距 Pitch	网链材质 Material	颜色 Color	转弯系数 Turn Radius
25.4mm	POM	白色/White 蓝色/Blue	2.5
25.4mm	PP	蓝色/Blue	2.5

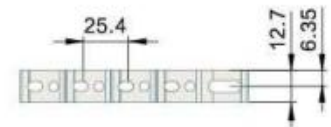
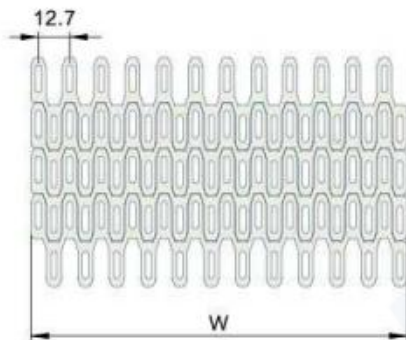

挡板高度 Cleat Height	—	材质 Material	重量 Weight(KG/SQ)	工作负荷 Working Capacity(N/M)
裙边高度 Side Apron Height	—	POM	7.6	20000
穿销材质 Pin Material	PP/NYLON/PBT DIAMETER:4.6mm	PP	5.3	14000

可选宽度 Available Width

塑料缩水率引致的正常误差：正负差距±3(mm) The normal error caused by the shrinkage of plastic: ±3(mm)

单片宽度 (Bulk Pieces Width)		组合宽度 (Assemble Width)
76mm	152mm	76*N
非标宽度 Nonstandard Width		非标定制前请和本公司联系 PLS Contact Hairise Confirm Width Before Booking

链轮 Sprocket	护栏 Guide	其余配件 Component
S55	R01-R42	C01-C57

Har7100A Series Flush Grid

MODULAR BELT

MODULAR BELT 7100A Series

P=25.4mm, T=12.7mm

OPEN AREA:50%



节距 Pitch	网链材质 Material	颜色 Color	转弯系数 Turn Radius
25.4mm	POM	蓝色/Blue	2.5
25.4mm	PP	白色/White	2.5

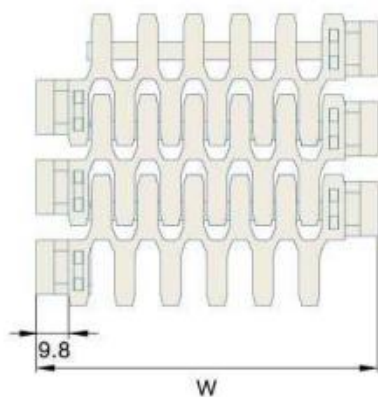

挡板高度 Cleat Height	—	材质 Material	重量 Weight(KG/SQ)	工作负荷 Working Capacity(N/M)
裙边高度 Side Apron Height	—	POM	7.7	600
穿销材质 Pin Material	PP/NYLON/PBT DIAMETER:4.6mm	PP	6.9	500

可选宽度 Available Width

塑料缩水率引致的正常误差：正负差距 ±3(mm) The normal error caused by the shrinkage of plastic: ±3(mm)

单片宽度 (Bulk Pieces Width)	组合宽度 (Assemble Width)
76mm	76*N
非标宽度 Nonstandard Width	非标定制前请和本公司联系 PLS Contact Hairise Confirm Width Before Booking

链轮 Sprocket	护栏 Guide	其余配件 Component
S55	R01-R42	C01-C57

Har7300 Series Flush Grid MODULAR BELT

MODULAR BELT 7300 Series

P=25.4mm, T=8.8mm

OPEN AREA:34%

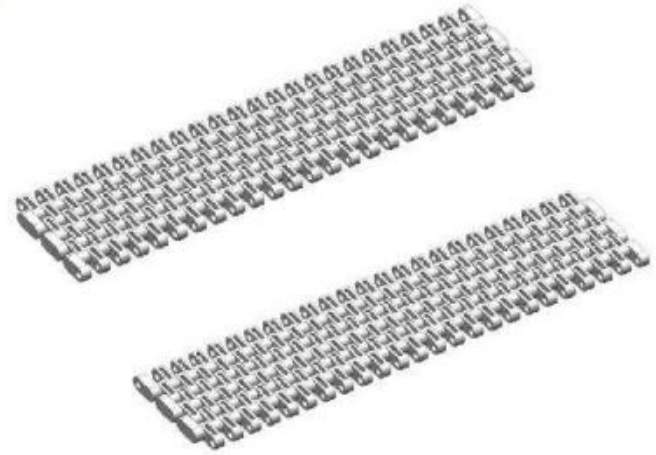

节距 Pitch	网链材质 Material	颜色 Color
25.4mm	POM	蓝色/Blue
25.4mm	POM	白色/White
25.4mm	PP	白色/White
25.4mm	PP	灰色/Grey

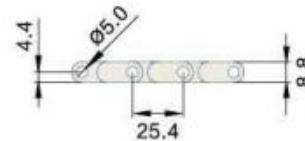
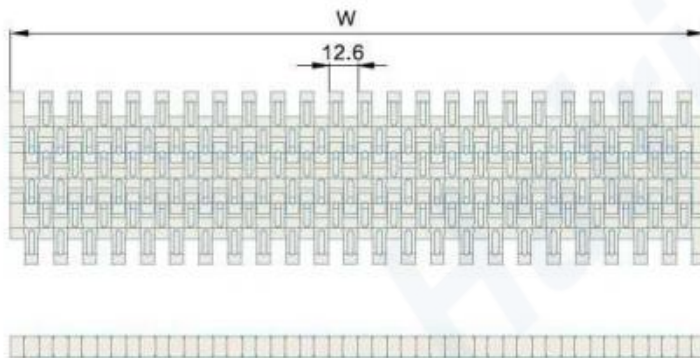

挡板高度 Cleat Height	50mm	材质 Material	重量 Weight(KG/SQ)	工作负荷 Working Capacity(N/M)
裙边高度 Side Apron Height	—	POM	6.3	23500
穿销材质 Pin Material	PP/NYLON/PBT DIAMETER:4.6mm	PP	4.3	15000

可选宽度 Available Width

塑料缩水率引致的正常误差: 正负差距 ±3(mm) The normal error caused by the shrinkage of plastic; ±3(mm)

单片宽度 (Bulk Pieces Width)	组合宽度 (Assemble Width)
304mm	304*N
非标宽度 Nonstandard Width	非标定制前请和本公司联系 PLS Contact Hairise Confirm Width Before Booking

链轮 Sprocket	护栏 Guide	其余配件 Component
S56	R01-R42	C01-C57

Har7705 Series Flat Top MODULAR BELT

MODULAR BELT 7705 Series
P=25.4mm, T=12.7mm
OPEN AREA:0%



节距 Pitch	网链材质 Material	颜色 Color
25.4mm	POM	咖啡/Brown 灰色/Grey
	PP	白色/White

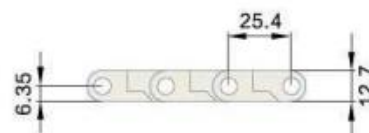
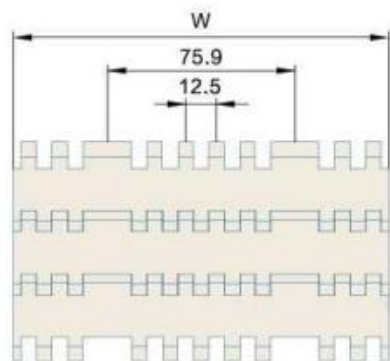

挡板高度 Cleat Height	—	材质 Material	重量 Weight(KG/SQ)	工作负荷 Working Capacity(N/M)
裙边高度 Side Apron Height	—	POM	14.85	21521
穿销材质 Pin Material	PP/NYLON/PBT DIAMETER:6mm	PP	9.03	26262
可选宽度 Available Width 塑料缩水率引致的正常误差: 正负差距 ±3(mm) The normal error caused by the shrinkage of plastic: ±3(mm)				
单片宽度 (Bulk Pieces Width)		组合宽度 (Assemble Width)		
76mm	152mm	76*N		
非标宽度 Nonstandard Width		非标定制前请和本公司联系 PLS Contact Hairise Confirm Width Before Booking		

链轮 Sprocket	护栏 Guide	其余配件 Component
S57	R01-R42	C01-C57

Har7706 Series Roller Top MODULAR BELT

MODULAR BELT 7706 Series
P=25.4mm, T=12.7mm
OPEN AREA:0%

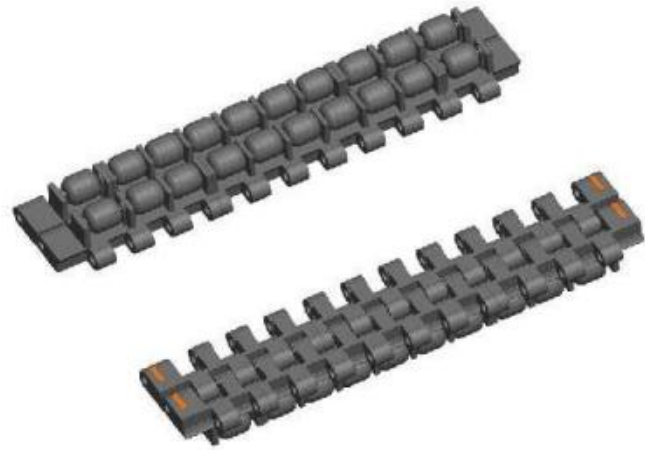

节距 Pitch	网链材质 Material	颜色 Color
25.4mm	POM	深灰色/Dark Grey

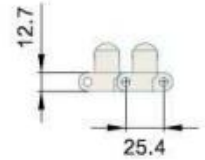
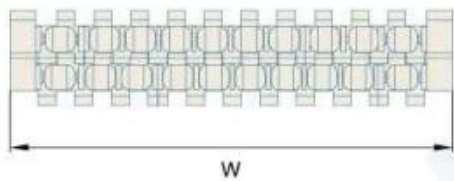

挡板高度 Cleat Height	—	材质 Material	重量 Weight(KG/SQ)	工作负荷 Working Capacity(N/M)
裙边高度 Side Apron Height	—	POM	26.7	36000
穿销材质 Pin Material	PP/NYLON/PBT DIAMETER:6mm	—	—	—
可选宽度 Available Width 塑料缩水率引致的正常误差：正负差距 ±3(mm) The normal error caused by the shrinkage of plastic; ±3(mm)				
单片宽度 (Bulk Pieces Width)			组合宽度 (Assemble Width)	
51mm	101mm	150mm	152+150*N	
非标宽度 Nonstandard Width			非标定制前请和本公司联系 PLS Contact Hairise Confirm Width Before Booking	

链轮 Sprocket	护栏 Guide	其余配件 Component
—	R01-R42	C01-C57

Har7910A Series Flush Grid MODULAR BELT

MODULAR BELT 7910A
P=25.4mm, T=12mm
OPEN AREA:43%

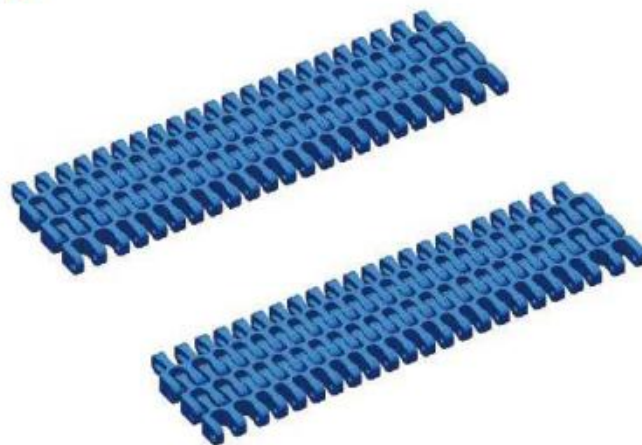

节距 Pitch	网链材质 Material	颜色 Color	转弯系数 Turn Radius
25.4mm	POM	深蓝色/Dark Blue	2.5

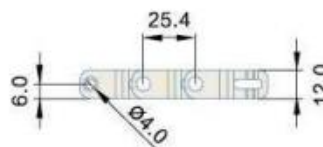
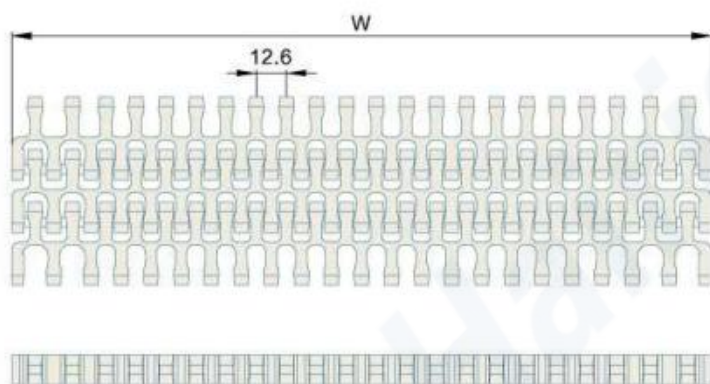

挡板高度 Cleat Height	—	材质 Material	重量 Weight(KG/SQ)	工作负荷 Working Capacity(N/M)
裙边高度 Side Apron Height	—	POM	8.0	20000
穿销材质 Pin Material	POM DIAMETER:4mm	—	—	—
可选宽度 Available Width 塑料缩水率引起的正常误差：正负差距 ±3(mm) The normal error caused by the shrinkage of plastic: ±3(mm)				
单片宽度 (Bulk Pieces Width)		组合宽度 (Assemble Width)		
204mm	301mm	301mm+204*N		
非标宽度 Nonstandard Width		非标定制前请和本公司联系 PLS Contact Hairise Confirm Width Before Booking		

链轮 Sprocket	护栏 Guide	其余配件 Component
S59	R01-R42	C01-C57

Har7910B Series Flush Grid MODULAR BELT

MODULAR BELT 7910B Series
P=25.4mm, T=12mm
OPEN AREA:43%



节距 Pitch	网链材质 Material	颜色 Color	转弯系数 Turn Radius
25.4mm	POM	浅湖蓝/ Blue	2.0

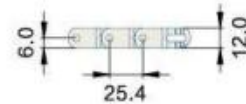
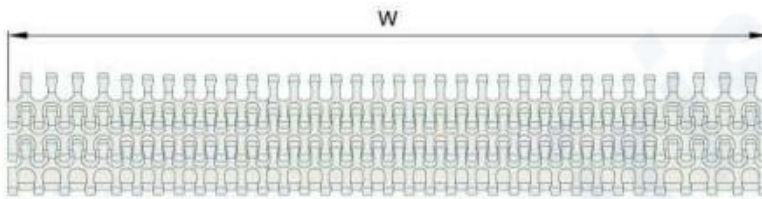

挡板高度 Cleat Height	—	材质 Material	重量 Weight(KG/SQ)	工作负荷 Working Capacity(N/M)
裙边高度 Side Apron Height	—	POM	7.8	20000
穿销材质 Pin Material	POM DIAMETER:4mm	—	—	—
可选宽度 Available Width 塑料缩水率引致的正常误差：正负差距 ±3(mm) The normal error caused by the shrinkage of plastic: ±3(mm)				
单片宽度 (Bulk Pieces Width)		组合宽度 (Assemble Width)		
301mm	204mm	301+204*N		
非标宽度 Nonstandard Width		非标定制前请和本公司联系 PLS Contact Hairise Confirm Width Before Booking		

链轮 Sprocket	护栏 Guide	其余配件 Component
S59	R01-R42	C01-C57

HarQNB Series Flat Top MODULAR BELT

MODULAR BELT QNB Series
P=25.4mm, T=8.8mm
OPEN AREA:0%

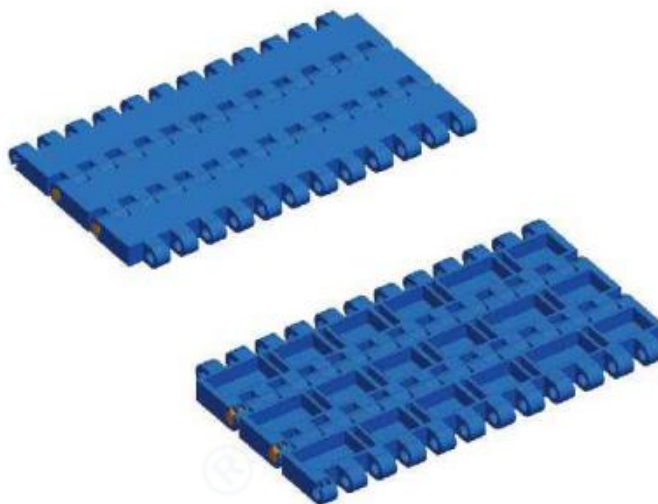

节距 Pitch	网链材质 Material	颜色 Color
25.4mm	POM	蓝色/Blue 黄色/Yellow

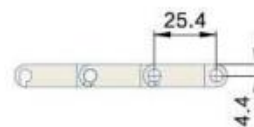
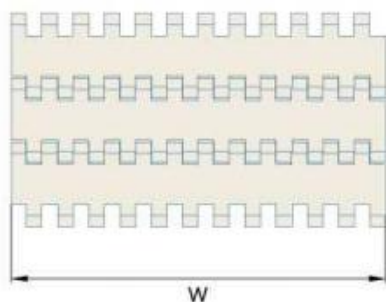

挡板高度 Cleat Height	—	材质 Material	重量 Weight(KG/SQ)	工作负荷 Working Capacity(N/M)
裙边高度 Side Apron Height	—	POM	8.4	35000
穿销材质 Pin Material	PP/NYLON/PBT DIAMETER:4.6mm	PP	5.3	20000
可选宽度 Available Width 塑料缩水率引致的正常误差: 正负差距 ±3(mm) The normal error caused by the shrinkage of plastic; ±3(mm)				
单片宽度 (Bulk Pieces Width)		组合宽度 (Assemble Width)		
76mm	152mm	76*N		
非标宽度 Nonstandard Width		非标定制前请和本公司联系 PLS Contact Hairise Confirm Width Before Booking		

链轮 Sprocket	护栏 Guide	其余配件 Component
S68	R01-R42	C01-C57

HarQNB Series Rubber Top MODULAR BELT

MODULAR BELT QNB Series
P=25.4mm, T=8.8mm
OPEN AREA:0%

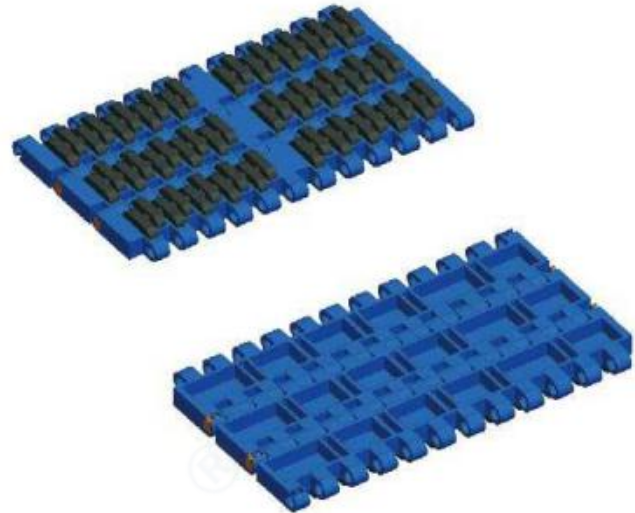

节距 Pitch	网链材质 Material	颜色 Color
25.4mm	PP	深蓝底黑胶/ Dark Blue Plate Black Rubber

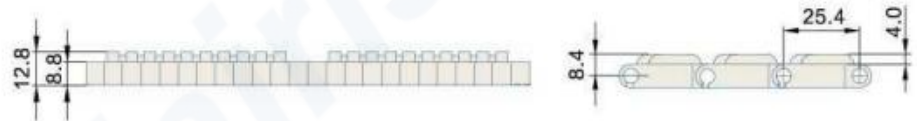
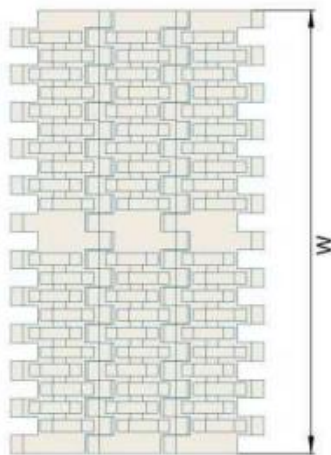

挡板高度 Cleat Height	—	材质 Material	重量 Weight(KG/SQ)	工作负荷 Working Capacity(N/M)
裙边高度 Side Apron Height	—	PP	7.5	21500
穿销材质 Pin Material	PP/NYLON/PBT DIAMETER:4.6mm	—	—	—
可选宽度 Available Width 塑料缩水率引致的正常误差：正负差距 ±3(mm) The normal error caused by the shrinkage of plastic: ±3(mm)				
单片宽度 (Bulk Pieces Width)		组合宽度 (Assemble Width)		
76mm	152mm	76*N		
非标宽度 Nonstandard Width		非标定制前请和本公司联系 PLS Contact Hairise Confirm Width Before Booking		

链轮 Sprocket	护栏 Guide	其余配件 Component
S68	R01-R42	C01-C57

HarQNC Series Nub Top MODULAR BELT

MODULAR BELT QNC Series
P=25.4mm, T=8.7mm
OPEN AREA:0%



节距 Pitch	网链材质 Material	颜色 Color
25.4mm	POM	蓝色/Blue 橘色/Orange

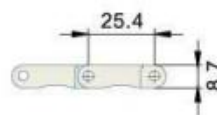
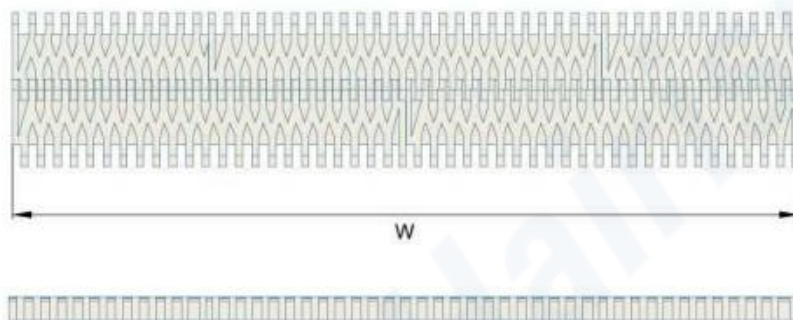

挡板高度 Cleat Height	—	材质 Material	重量 Weight(KG/SQ)	工作负荷 Working Capacity(N/M)
裙边高度 Side Apron Height	—	POM	7.0	15000
穿销材质 Pin Material	PP/NYLON/PBT DIAMETER: 4.35mm	—	—	—
可选宽度 Available Width 塑料缩水率引起的正常误差: 正负差距 ±3(mm) The normal error caused by the shrinkage of plastic: ±3(mm)				
单片宽度 (Bulk Pieces Width)		组合宽度 (Assemble Width)		
76mm	152mm	76mm*N		
非标宽度 Nonstandard Width		非标定制前请和本公司联系 PLS Contact Hairise Confirm Width Before Booking		

链轮 Sprocket	护栏 Guide	其余配件 Component
S69	R01-R42	C01-C57

Har1400 Series Flat Top MODULAR BELT

MODULAR BELT 1400 Series
P=25.4mm, T=12.7mm

节距 Pitch	网链材质 Material	颜色 Color
25.4mm	POM	深蓝色/ Dark Blue
25.4mm	PP	白色/White

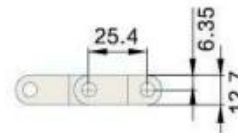
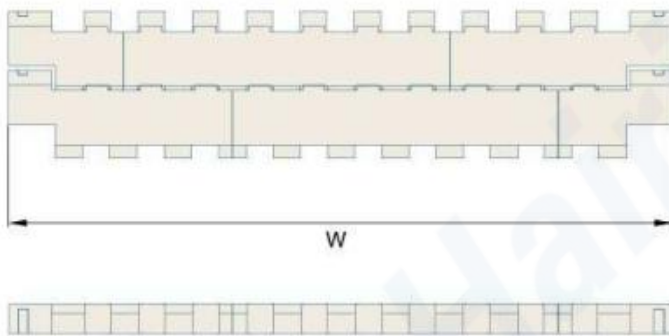
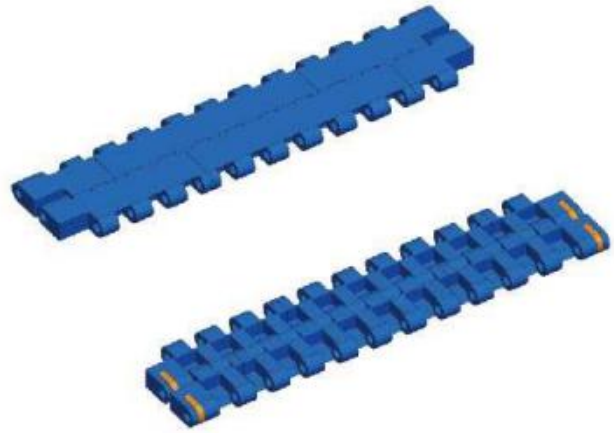

挡板高度 Cleat Height	—	材质 Material	重量 Weight(KG/SQ)	工作负荷 Working Capacity(N/M)
裙边高度 Side Apron Height	—	POM	13.43	36000
穿销材质 Pin Material	PP/NYLON/PBT DIAMETER:6mm	PP	9.03	18000
可选宽度 Available Width 塑料缩水率引致的正常误差: 正负差距 ±3(mm) The normal error caused by the shrinkage of plastic; ±3(mm)				
单片宽度 (Bulk Pieces Width)			组合宽度 (Assemble Width)	
50mm	152mm	100mm	50+101+25.5*N	
非标宽度 Nonstandard Width			非标定制前请和本公司联系 PLS Contact Hairise Confirm Width Before Booking	

链轮 Sprocket	护栏 Guide	其余配件 Component
S30	R01-R42	C01-C57

Har1400 Series Flat Top With Positrack MODULAR BELT

MODULAR BELT 1400 Series
P=25.4mm, T=12.7mm
OPEN AREA:0%

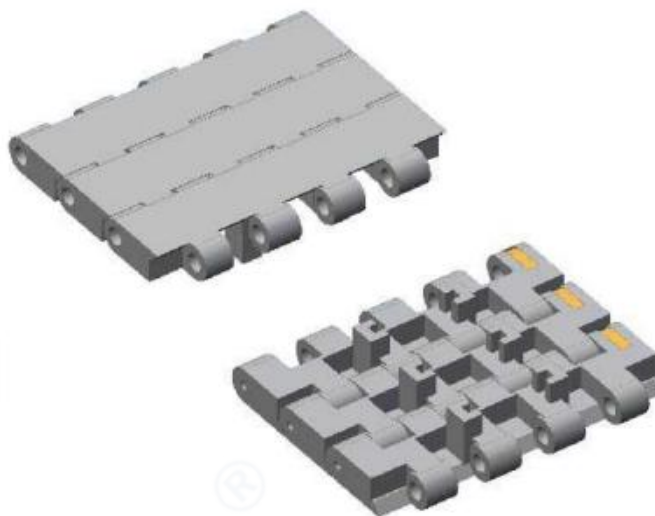

节距 Pitch	网链材质 Material	颜色 Color
25.4mm	POM	蓝色/Blue

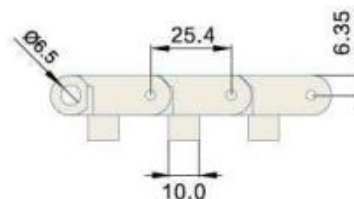
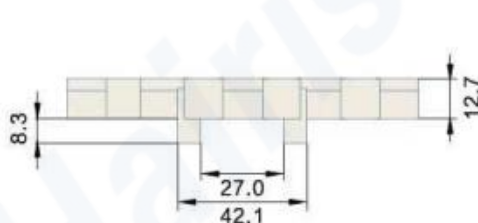
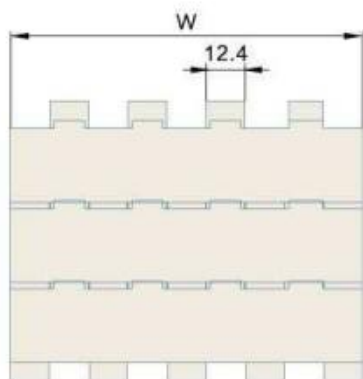

挡板高度 Cleat Height	—	材质 Material	—	重量 Weight(KG/SQ)	—	工作负荷 Working Capacity(N/M)	—
裙边高度 Side Apron Height	—	POM	—	13.5	—	37200	—
穿销材质 Pin Material	PP/NYLON/PBT DIAMETER:6mm	—	—	—	—	—	—
可选宽度 Available Width 塑料缩水率引致的正常误差：正负差距 ±3(mm) The normal error caused by the shrinkage of plastic: ±3(mm)							
单片宽度 (Bulk Pieces Width)		组合宽度 (Assemble Width)					
114.3mm	190.5mm	114.3/190.5					
非标宽度 Nonstandard Width		非标定制前请和本公司联系 PLS Contact Hairise Confirm Width Before Booking					

链轮 Sprocket	护栏 Guide	其余配件 Component
S30	R01-R42	C01-C57

Har1400 Series Flat Top With Positrack

MODULAR BELT

MODULAR BELT 1400 Series
 P=25.4mm, T=12.8mm
 OPEN AREA:0%

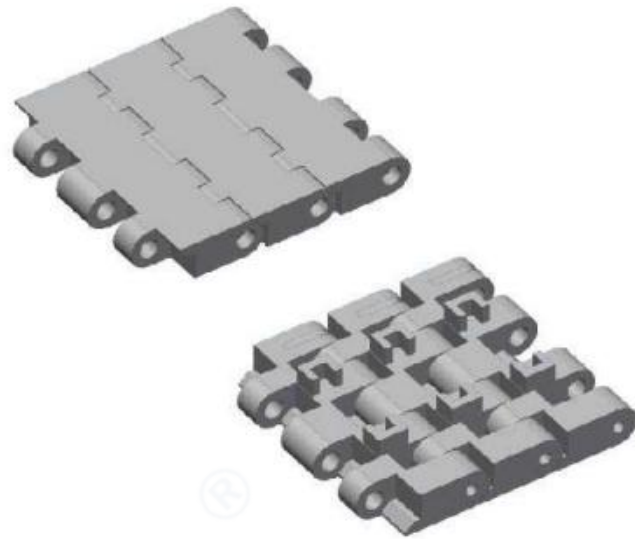

节距 Pitch	网链材质 Material	颜色 Color
25.4mm	POM	蓝色/Blue

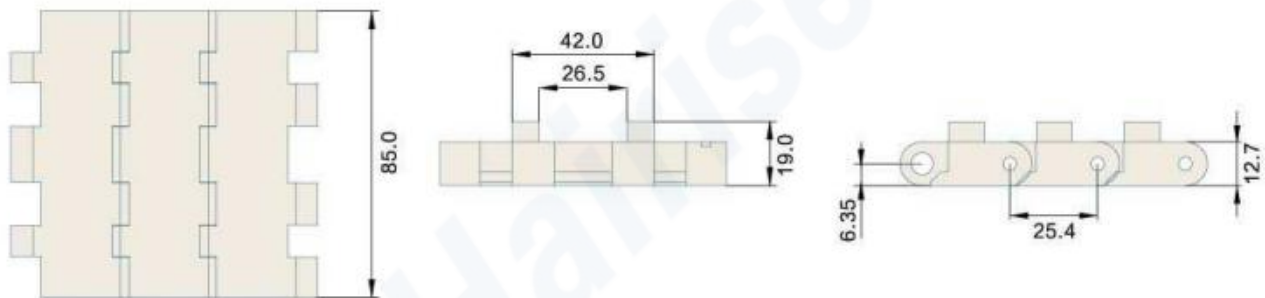

挡板高度 Cleat Height	—	材质 Material	重量 Weight(KG/SQ)	工作负荷 Working Capacity(N/M)
裙边高度 Side Apron Height	—	POM	13.5	37200
穿销材质 Pin Material	PP/NYLON/PBT DIAMETER:6mm	—	—	—
可选宽度 Available Width 塑料缩水率引致的正常误差：正负差距 ±3(mm) The normal error caused by the shrinkage of plastic: ±3(mm)				
单片宽度 (Bulk Pieces Width)		组合宽度 (Assemble Width)		
85mm		85		
非标宽度 Nonstandard Width		非标定制前请和本公司联系 PLS Contact Hairise Confirm Width Before Booking		

链轮 Sprocket	护栏 Guide	其余配件 Component
S30	R01-R42	C01-C57

Har1400 Series Diamond Grid Anti Slip MODULAR BELT

MODULAR BELT 1400 Series
 P=25.4mm, T=12.7mm
 OPEN AREA:0%

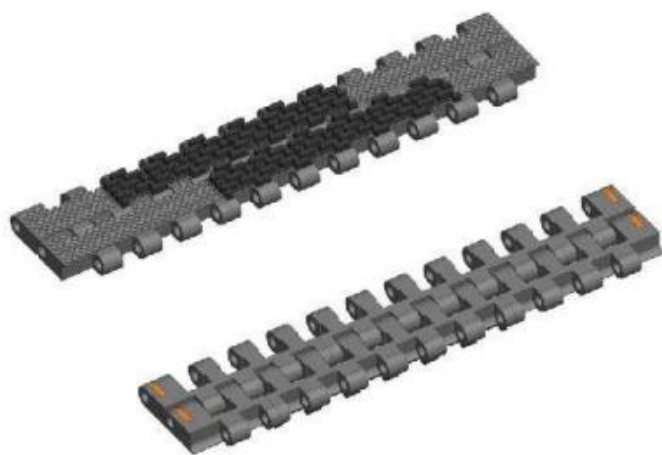

节距 Pitch	网链材质 Material	颜色 Color
25.4mm	PP	灰底黑胶/Grey Plate Black Rubber

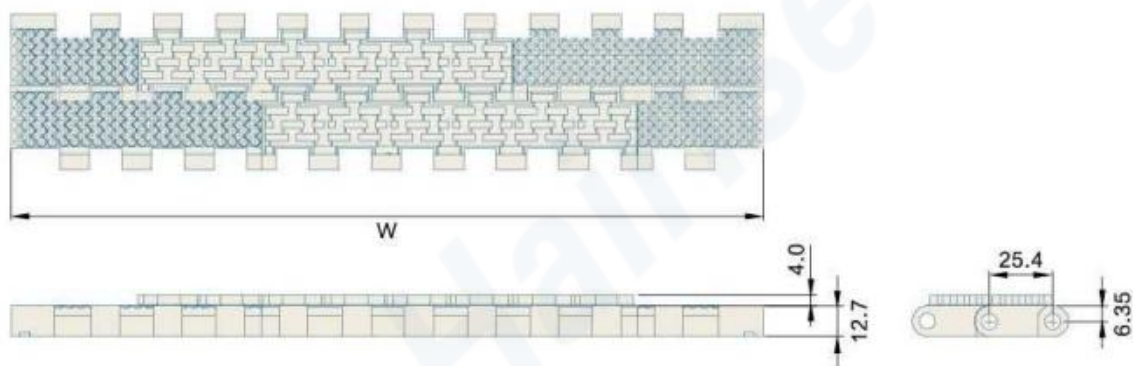

挡板高度 Cleat Height	—	材质 Material	重量 Weight(KG/SQ)	工作负荷 Working Capacity(N/M)
裙边高度 Side Apron Height	—	PP	11.18	26780
穿销材质 Pin Material	PP/NYLON/PBT DIAMETER:6mm	—	—	—
可选宽度 Available Width 塑料缩水率引致的正常误差：正负差距 ±3(mm) The normal error caused by the shrinkage of plastic: ±3(mm)				
单片宽度 (Bulk Pieces Width)		组合宽度 (Assemble Width)		
51mm	152mm	102mm	51+102+152*N	
非标宽度 Nonstandard Width		非标定制前请和本公司联系 PLS Contact Hairise Confirm Width Before Booking		

链轮 Sprocket	护栏 Guide	其余配件 Component
S30	R01-R42	C01-C57

Har1600 Series Flat Top MODULAR BELT

MODULAR BELT 1600 Series
P=25.4mm, T=8.7mm
OPEN AREA:0%

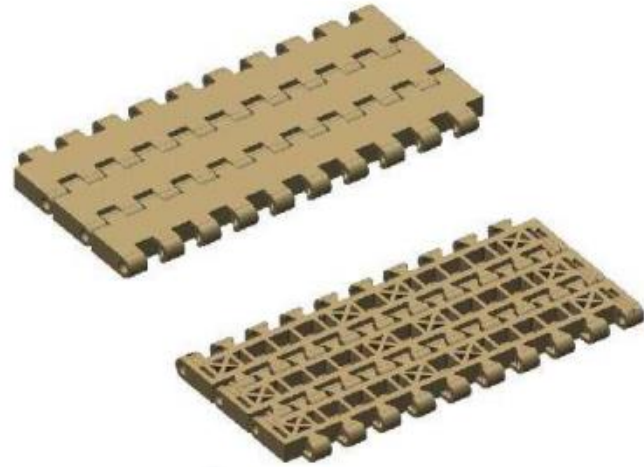

节距 Pitch	网链材质 Material	颜色 Color
25.4mm	POM	咖啡色/Brown

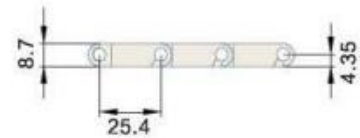
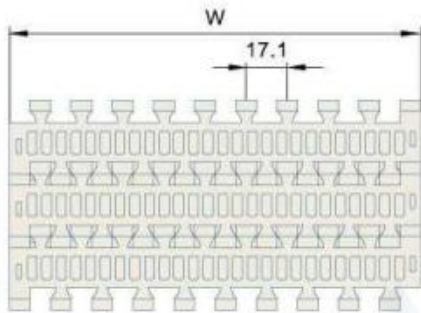

挡板高度 Cleat Height	—	材质 Material	重量 Weight(KG/SQ)	工作负荷 Working Capacity(N/M)
裙边高度 Side Apron Height	—	POM	7.71	23000
穿销材质 Pin Material	PP/NYLON/PBT DIAMETER:4.6mm	PP	5.37	11000
可选宽度 Available Width 塑料缩水率引致的正常误差：正负差距 ±3(mm) The normal error caused by the shrinkage of plastic: ±3(mm)				
单片宽度 (Bulk Pieces Width)		组合宽度 (Assemble Width)		
170mm		170+85*N		
非标宽度 Nonstandard Width		非标定制前请和本公司联系 PLS Contact Hairise Confirm Width Before Booking		

链轮 Sprocket	护栏 Guide	其余配件 Component
S33	R01-R42	C01-C57

Har1600 Series Flush Grid MODULAR BELT

MODULAR BELT 1600 Series
P=25.4mm, T=8.7mm
OPEN AREA:30%



节距 Pitch	网链材质 Material	颜色 Color
25.4mm	POM	深灰色/Dark Gray

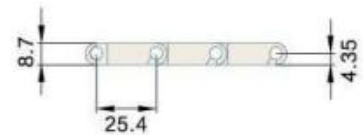
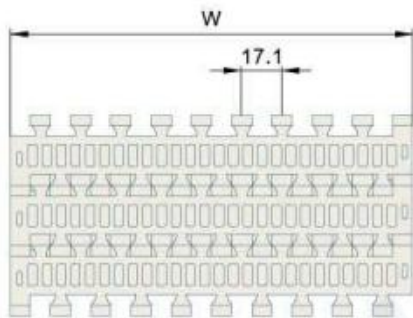

挡板高度 Cleat Height	—	材质 Material	重量 Weight(KG/SQ)	工作负荷 Working Capacity(N/M)
裙边高度 Side Apron Height	—	POM	6.84	22000
穿销材质 Pin Material	PP/NYLON/PBT DIAMETER:4.6mm	PP	4.59	11000
可选宽度 Available Width 塑料缩水率引致的正常误差: 正负差距 ±3(mm) The normal error caused by the shrinkage of plastic: ±3(mm)				
单片宽度 (Bulk Pieces Width)		组合宽度 (Assemble Width)		
170mm	85mm	170+85*N		
非标宽度 Nonstandard Width		非标定制前请和本公司联系 PLS Contact Hairise Confirm Width Before Booking		

链轮 Sprocket	护栏 Guide	其余配件 Component
S33	R01-R42	C01-C57

Har1600 Series Flat Top With Positrack

MODULAR BELT

MODULAR BELT 1600 Series
 P=25.4mm, T=8.7mm
 OPEN AREA:0%

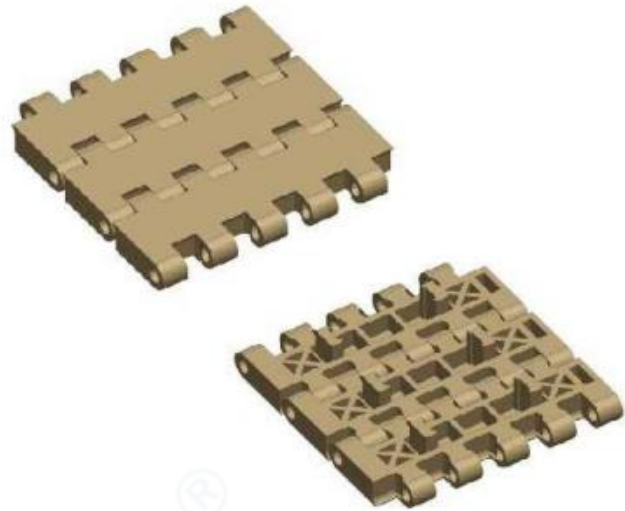

节距 Pitch	网链材质 Material	颜色 Color
25.4mm	POM	棕色/Brown

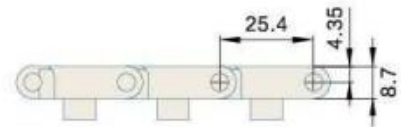
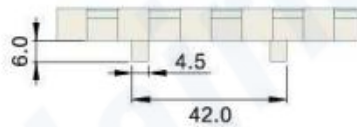
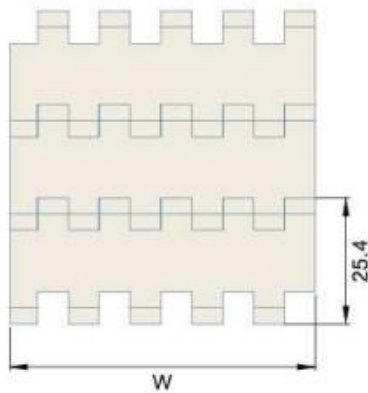

挡板高度 Cleat Height	—	材质 Material	重量 Weight(KG/M)	工作负荷 Working Capacity(N/M)
裙边高度 Side Apron Height	—	POM	0.65	1850
穿销材质 Pin Material	PP/NYLON/PBT DIAMETER:4.6mm	—	—	—
可选宽度 Available Width 塑料缩水率引致的正常误差：正负差距 ±3(mm) The normal error caused by the shrinkage of plastic: ±3(mm)				
单片宽度 (Bulk Pieces Width)		组合宽度 (Assemble Width)		
85mm	170mm	85*N		
非标宽度 Nonstandard Width		非标定制前请和本公司联系 PLS Contact Hairise Confirm Width Before Booking		

链轮 Sprocket	护栏 Guide	其余配件 Component
S33	R01-R42	C01-C57

Har1600T Series Flat Top MODULAR BELT

MODULAR BELT 1600T Series
P=25.4mm, T=10mm
OPEN AREA:0%



节距 Pitch	网链材质 Material	颜色 Color
25.4mm	POM	白色/White 灰色/ Grey
25.4mm	PP	白色/White

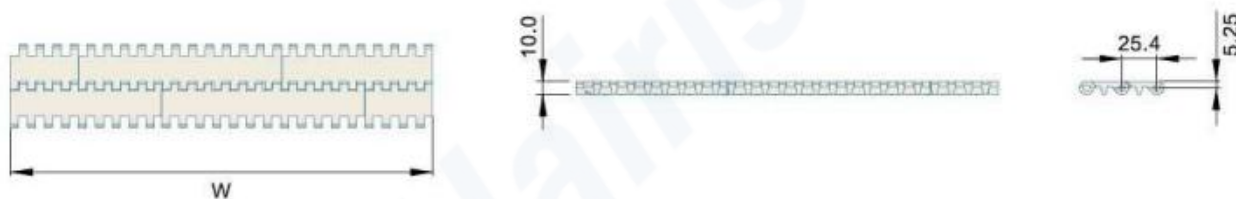

挡板高度 Cleat Height	50mm/100mm	材质 Material	POM	重量 Weight(KG/SQ)	7.3	工作负荷 Working Capacity(N/M)	21000
裙边高度 Side Apron Height	—						
穿销材质 Pin Material	PP/NYLON/PBT DIAMETER:4.6mm	PP		5.0		10400	
可选宽度 Available Width 塑料缩水率引致的正常误差：正负差距 ±3(mm) The normal error caused by the shrinkage of plastic: ±3(mm)							
单片宽度 (Bulk Pieces Width)				组合宽度 (Assemble Width)			
152mm				152mm*N			
非标宽度 Nonstandard Width				非标定制前请和本公司联系 PLS Contact Hairise Confirm Width Before Booking			

链轮 Sprocket	护栏 Guide	其余配件 Component
S33	R01-R42	C01-C57

Har2501 Series Flat Top MODULAR BELT

MODULAR BELT 2501 Series
P=25.4mm, T=13mm
OPEN AREA:0%

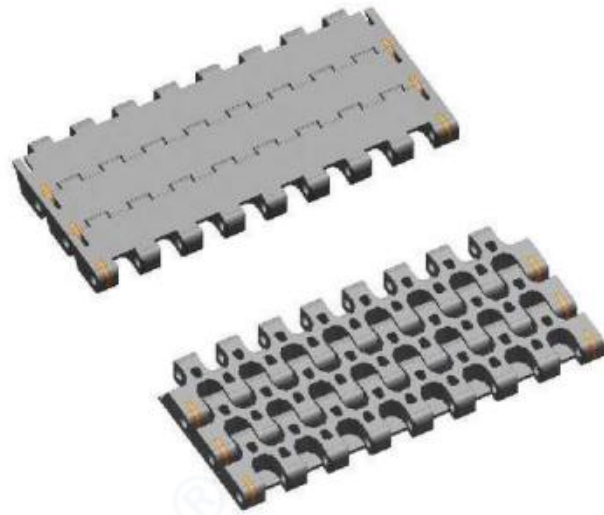

节距 Pitch	网链材质 Material	颜色 Color
25.4mm	POM	白色/White

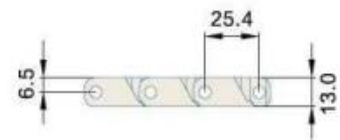
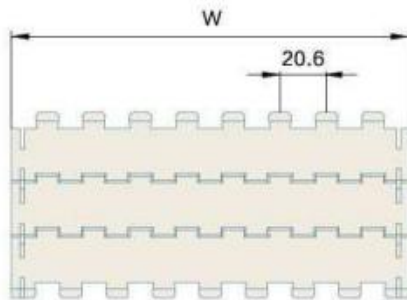

挡板高度 Cleat Height	—	材质 Material	重量 Weight(KG/SQ)	工作负荷 Working Capacity(N/M)
裙边高度 Side Apron Height	—	POM	11.5	17200
穿销材质 Pin Material	PP/NYLON/PBT DIAMETER:4.6mm	PP	6.9	10600
可选宽度 Available Width 塑料缩水率引致的正常误差: 正负差距 ±3(mm) The normal error caused by the shrinkage of plastic; ±3(mm)				
单片宽度 (Bulk Pieces Width)		组合宽度 (Assemble Width)		
175mm		175+20*N		
非标宽度 Nonstandard Width		非标定制前请和本公司联系 PLS Contact Hairise Confirm Width Before Booking		

链轮 Sprocket	护栏 Guide	其余配件 Component
S46	R01-R42	C01-C57

Har2501 Series Nub Top MODULAR BELT

MODULAR BELT 2501 Series
P=25.4mm, T=15.5mm
OPEN AREA:40%



节距 Pitch	网链材质 Material	颜色 Color
25.4mm	PP	白色/White

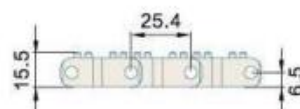
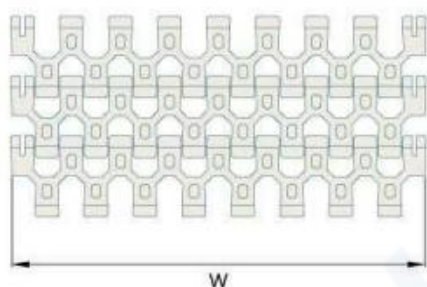

挡板高度 Cleat Height	—	材质 Material	重量 Weight(KG/SQ)	工作负荷 Working Capacity(N/M)
裙边高度 Side Apron Height	—	POM	10.9	17200
穿销材质 Pin Material	PP/NYLON/PBT DIAMETER:5mm	PP	7.4	10600
可选宽度 Available Width 塑料缩水率引致的正常误差：正负差距 ±3(mm) The normal error caused by the shrinkage of plastic: ±3(mm)				
单片宽度 (Bulk Pieces Width)		组合宽度 (Assemble Width)		
173mm		173+20*N		
非标宽度 Nonstandard Width		非标定制前请和本公司联系 PLS Contact Hairise Confirm Width Before Booking		

链轮 Sprocket	护栏 Guide	其余配件 Component
S46	R01-R42	C01-C57

Har2501 Series Flush Grid MODULAR BELT

MODULAR BELT 2501 Series
P=25.4mm, T=13mm
OPEN AREA:40%

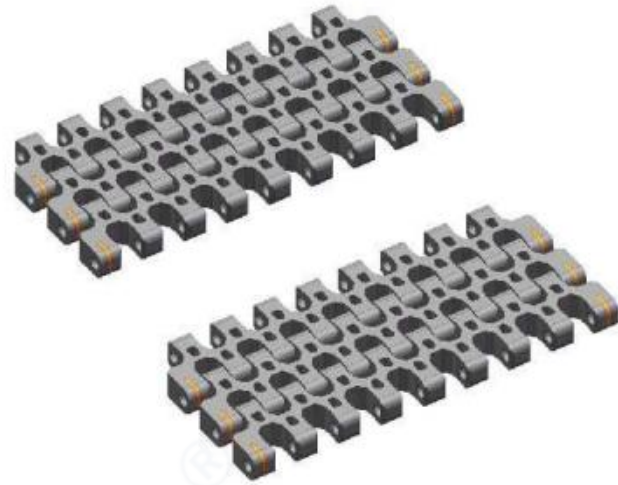

节距 Pitch	网链材质 Material	颜色 Color
25.4mm	POM	白色/White
25.4mm	PP	白色/White

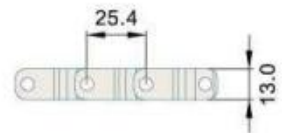
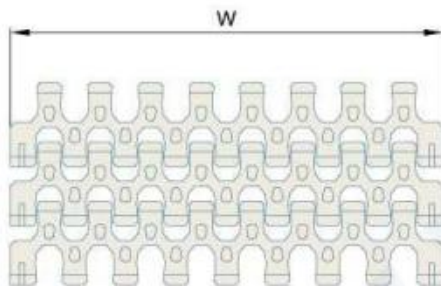

挡板高度 Cleat Height	—	材质 Material	重量 Weight(KG/SQ)	工作负荷 Working Capacity(N/M)
裙边高度 Side Apron Height	—	PP	6.4	10600
穿销材质 Pin Material	PP/NYLON/PBT DIAMETER:5mm	POM	9.4	17200
可选宽度 Available Width 塑料缩水率引致的正常误差：正负差距 ±3(mm) The normal error caused by the shrinkage of plastic; ±3(mm)				
单片宽度 (Bulk Pieces Width)		组合宽度 (Assemble Width)		
175mm		175*N		
非标宽度 Nonstandard Width		非标定制前请和本公司联系 PLS Contact Hairise Confirm Width Before Booking		

链轮 Sprocket	护栏 Guide	其余配件 Component
S46	R01-R42	C01-C57

Har2542 Series Flat Top With Positrack MODULAR BELT

MODULAR BELT 2542 Series
P=25.4mm, T=8.7mm
OPEN AREA:0%

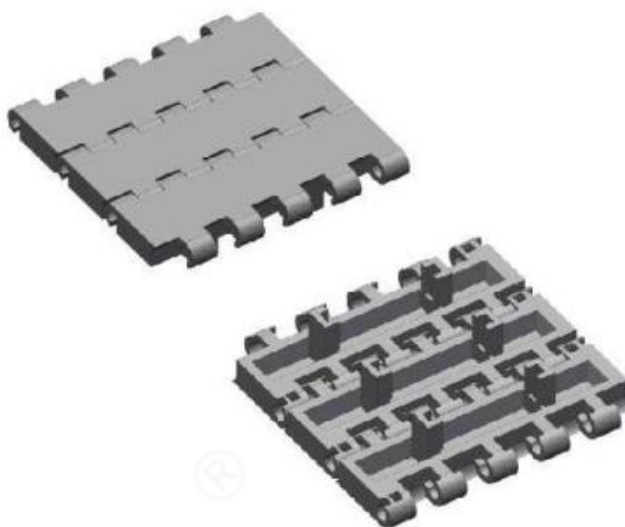

节距 Pitch	网链材质 Material	颜色 Color
25.4mm	POM	灰色/Grey 深灰色/Dark Grey

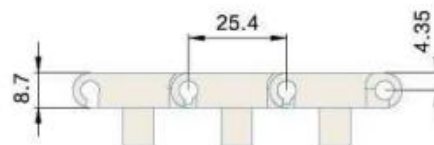
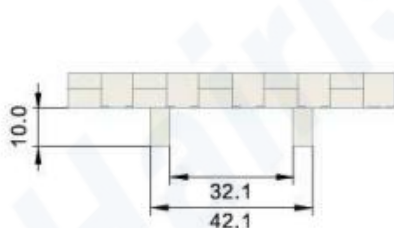
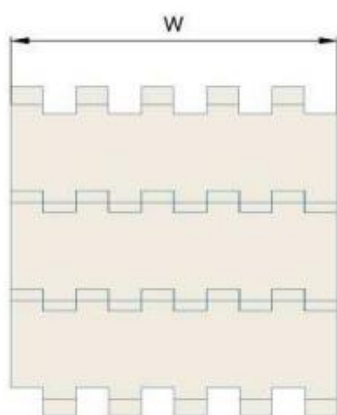

挡板高度 Cleat Height	—	材质 Material	重量 Weight(KG/SQ)	工作负荷 Working Capacity(N/M)
裙边高度 Side Apron Height	—	POM	7.8	25000
穿销材质 Pin Material	PP/NYLON/PBT	—	—	—

可选宽度 Available Width

塑料缩水率引致的正常误差：正负差距 ±3(mm) The normal error caused by the shrinkage of plastic: ±3(mm)

单片宽度 (Bulk Pieces Width)		组合宽度 (Assemble Width)
85mm	170mm	85*N
非标宽度 Nonstandard Width		非标定制前请和本公司联系 PLS Contact Hairise Confirm Width Before Booking

链轮 Sprocket	护栏 Guide	其余配件 Component
S48	R01-R42	C01-C57

Har2542 Series Rubber Top MODULAR BELT

MODULAR BELT 2542 Series
P=25.4mm, T=11.2mm
OPEN AREA:0%

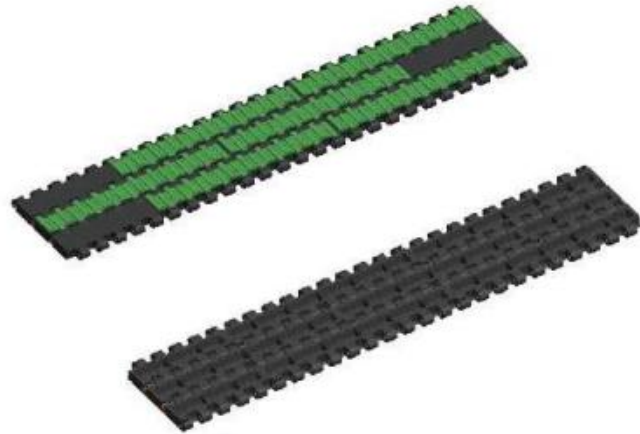

节距 Pitch	网链材质 Material	颜色 Color
25.4mm	PP	深灰底绿胶/ Dark Grey Plate Green Rubber

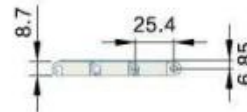
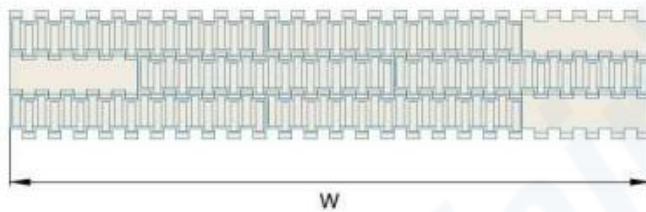

挡板高度 Cleat Height	—	材质 Material	重量 Weight(KG/SQ)	工作负荷 Working Capacity(N/M)
裙边高度 Side Apron Height	—	PP	8.7	25000
穿销材质 Pin Material	PP/NYLON/PBT DIAMETER:4.6mm	—	—	—
可选宽度 Available Width 塑料缩水率引致的正常误差：正负差距 ±3(mm) The normal error caused by the shrinkage of plastic: ±3(mm)				
单片宽度 (Bulk Pieces Width)		组合宽度 (Assemble Width)		
85mm	170mm	85*N		
非标宽度 Nonstandard Width		非标定制前请和本公司联系 PLS Contact Hairise Confirm Width Before Booking		

链轮 Sprocket	护栏 Guide	其余配件 Component
S48	R01-R42	C01-C57

Har900 Series Flat Top MODULAR BELT

MODULAR BELT 900 Series
P=27.2mm, T=9.8mm
OPEN AREA:0%

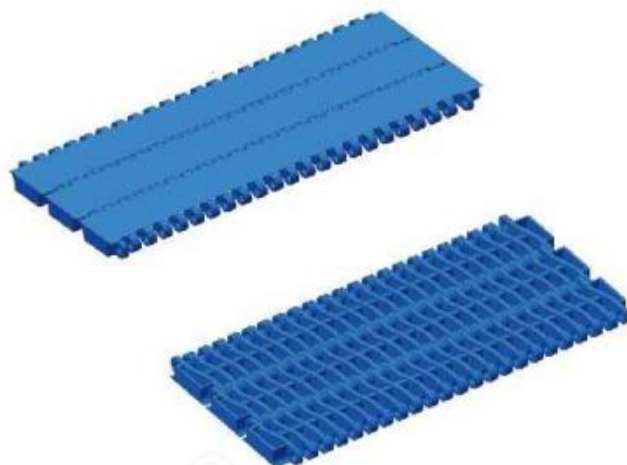

节距 Pitch	网链材质 Material	颜色 Color
27.2mm	POM	蓝色/Blue
27.2mm	PP	灰色/Grey

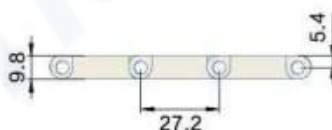
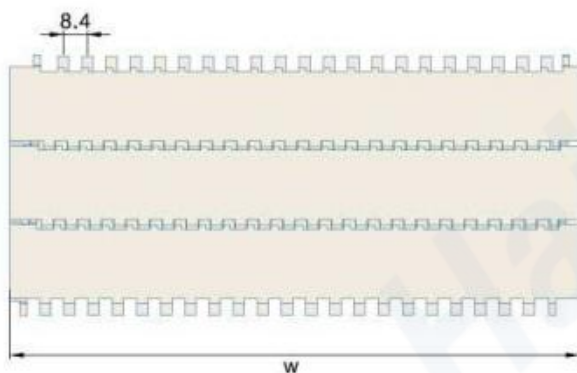

挡板高度 Cleat Height	32/50mm	材质 Material	POM	重量 Weight(KG/SQ)	7.3	工作负荷 Working Capacity(N/M)	10400
裙边高度 Side Apron Height	—						
穿销材质 Pin Material	PP/NYLON/PBT DIAMETER:5mm	PP		5.5		22000	
可选宽度 Available Width 塑料缩水率引致的正常误差：正负差距 ±3(mm) The normal error caused by the shrinkage of plastic: ±3(mm)							
单片宽度 (Bulk Pieces Width)				组合宽度 (Assemble Width)			
50mm	152mm	143mm	143+50+152*N				
非标宽度 Nonstandard Width				非标定制前请和本公司联系 PLS Contact Hairise Confirm Width Before Booking			

链轮 Sprocket	护栏 Guide	其余配件 Component
S20-S23	R01-R42	C01-C57

Har900 Series Flush Grid MODULAR BELT

MODULAR BELT 900 Series
P=27.2mm, T=8.8mm
OPEN AREA:38%

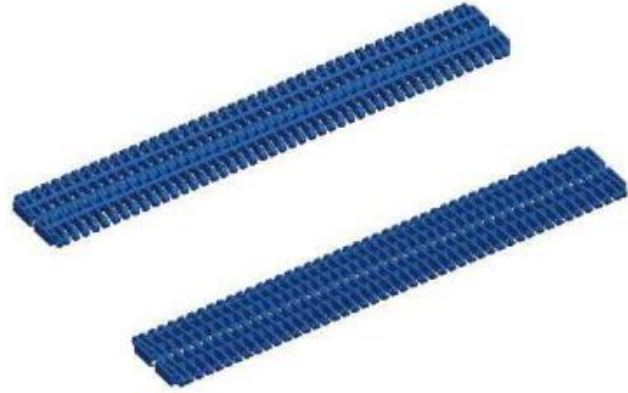

节距 Pitch	网链材质 Material	颜色 Color
27.2mm	POM	蓝色/Blue
27.2mm	PP	灰色/Grey

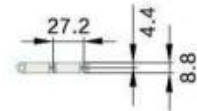
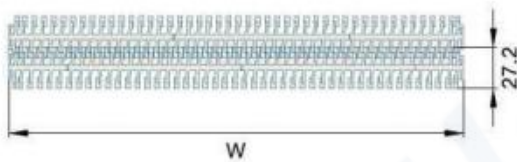

挡板高度 Cleat Height	32/50mm	材质 Material	POM	重量 Weight(KG/SQ)	6.5	工作负荷 Working Capacity(N/M)	22000
裙边高度 Side Apron Height	—						
穿销材质 Pin Material	PP/NYLON/PBT DIAMETER:4.6mm	PP		4.54		10400	
可选宽度 Available Width 塑料缩水率引致的正常误差：正负差距 ±3(mm) The normal error caused by the shrinkage of plastic; ±3(mm)							
单片宽度 (Bulk Pieces Width)			组合宽度 (Assemble Width)				
50mm	152mm	143mm	143+50+152*N				
非标宽度 Nonstandard Width			非标定制前请和本公司联系 PLS Contact Hairise Confirm Width Before Booking				

链轮 Sprocket	护栏 Guide	其余配件 Component
S20-S23	R01-R42	C01-C57

Har900 Series Perforated Flat Top MODULAR BELT

MODULAR BELT 900 Series
 P=27.2mm, T=9.8mm
 OPEN AREA:7.9%

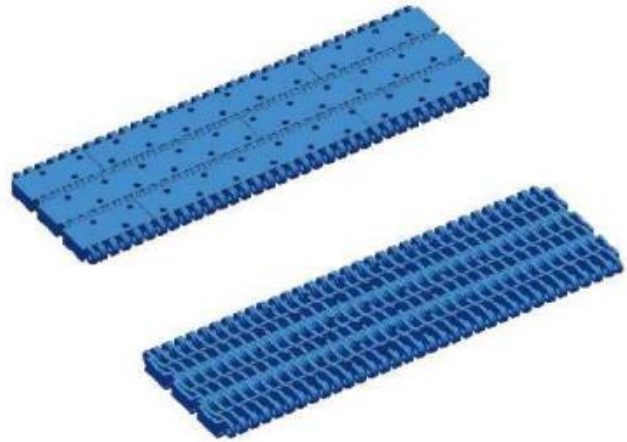

节距 Pitch	网链材质 Material	颜色 Color
27.2mm	POM	蓝色/Blue
27.2mm	PP	蓝色/Blue

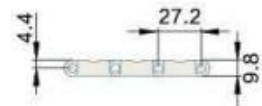
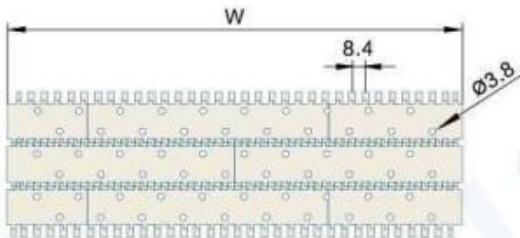

挡板高度 Cleat Height	32/50mm	材质 Material	POM	重量 Weight(KG/SQ)	7.0	工作负荷 Working Capacity(N/M)	22000
裙边高度 Side Apron Height	—						
穿销材质 Pin Material	PP/NYLON/PBT DIAMETER:4.6mm	PP		5.2		10400	

可选宽度 Available Width
 塑料缩水率引致的正常误差; 正负差距 ±3(mm) The normal error caused by the shrinkage of plastic; ±3(mm)

单片宽度 (Bulk Pieces Width)			组合宽度 (Assemble Width)
50mm	152mm	143mm	50+144+153+9*N
非标宽度 Nonstandard Width			非标定制前请和本公司联系 PLS Contact Hairise Confirm Width Before Booking

链轮 Sprocket	护栏 Guide	其余配件 Component
S20-S23	R01-R42	C01-C57

Har900 Series Rubber Top MODULAR BELT

MODULAR BELT 900 Series
P=27.2mm, T=9.8mm
OPEN AREA:0%

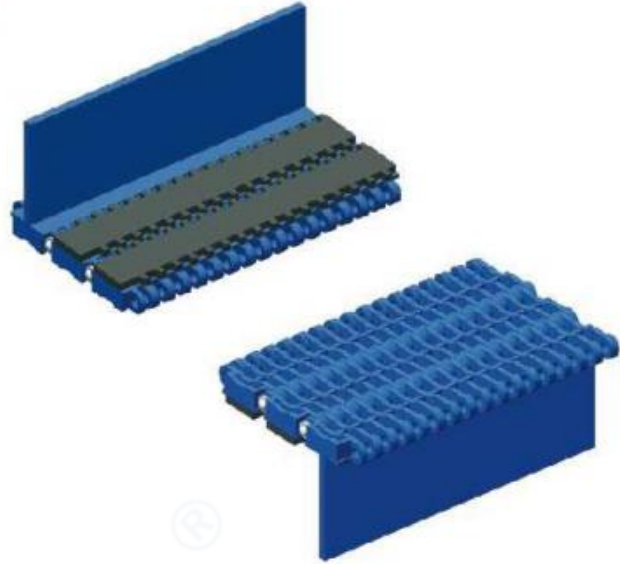

节距 Pitch	网链材质 Material	颜色 Color
27.2mm	PP	灰底黑胶/ Grey Plate Black Rubber

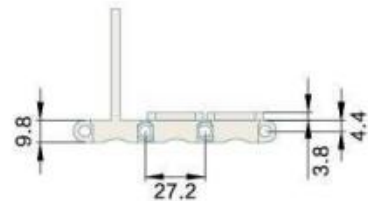
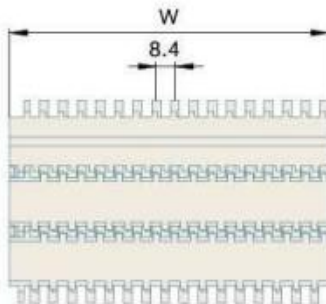

挡板高度 Cleat Height	32/50mm	材质 Material	重量 Weight(KG/SQ)	工作负荷 Working Capacity(N/M)
裙边高度 Side Apron Height	—	PP	5.86	14900
穿销材质 Pin Material	PP/NYLON/PBT DIAMETER:4.6mm	—	—	—
可选宽度 Available Width 塑料缩水率引致的正常误差; 正负差距 ±3(mm) The normal error caused by the shrinkage of plastic; ±3(mm)				
单片宽度 (Bulk Pieces Width)		组合宽度 (Assemble Width)		
50mm	152mm	143mm	143+50+152*N	
非标宽度 Nonstandard Width		非标定制前请和本公司联系 PLS Contact Hairise Confirm Width Before Booking		

链轮 Sprocket	护栏 Guide	其余配件 Component
S20-S23	R01-R42	C01-C57

Har900 Series Flush Grid With Rubber MODULAR BELT

MODULAR BELT 900 Series
P=27.2mm, T=14mm
OPEN AREA:0%



节距 Pitch	网链材质 Material	颜色 Color
27.2 mm	PP	灰底黑胶/ Grey Plate Black Rubber

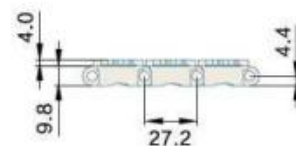
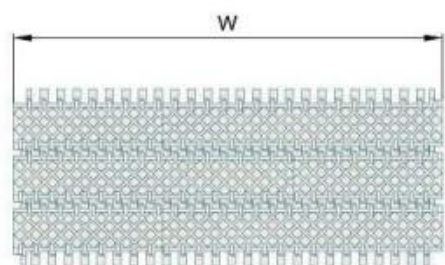

挡板高度 Cleat Height	32/50mm	材质 Material	PP	重量 Weight(KG/SQ)	5.86	工作负荷 Working Capacity(N/M)	13200
裙边高度 Side Apron Height	—						
穿销材质 Pin Material	PP/NYLON/PBT DIAMETER:4.6mm	—	—	—	—	—	—
可选宽度 Available Width 塑料缩水率引致的正常误差：正负差距 ±3(mm) The normal error caused by the shrinkage of plastic: ±3(mm)							
单片宽度 (Bulk Pieces Width)				组合宽度 (Assemble Width)			
50mm	152mm	143mm	50+143+152*N				
非标宽度 Nonstandard Width				非标定制前请和本公司联系 PLS Contact Hairise Confirm Width Before Booking			

链轮 Sprocket	护栏 Guide	其余配件 Component
S20-S23	R01-R42	C01-C57

Har900 Series Raised Rib MODULAR BELT

MODULAR BELT 900 Series
P=27.2mm, T=14.3mm
OPEN AREA:38%



节距 Pitch	网链材质 Material	颜色 Color
27.2mm	POM	蓝色/Blue

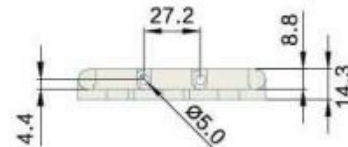
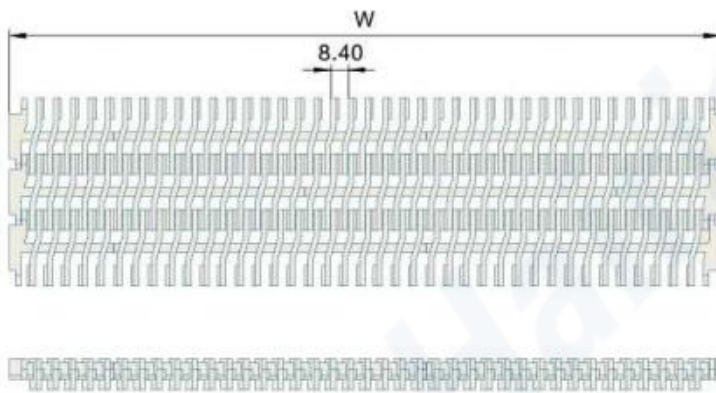

挡板高度 Cleat Height	32/50mm	材质 Material	POM	重量 Weight(KG/SQ)	8.19	工作负荷 Working Capacity(N/M)	22000
裙边高度 Side Apron Height	—						
穿销材质 Pin Material	PP/NYLON/PBT DIAMETER:4.6mm	—	—	—	—	—	—
可选宽度 Available Width 塑料缩水率引致的正常误差; 正负差距 ±3(mm) The normal error caused by the shrinkage of plastic; ±3(mm)							
单片宽度 (Bulk Pieces Width)				组合宽度 (Assemble Width)			
50mm	152mm	143mm	143+50+152*N				
非标宽度 Nonstandard Width				非标定制前请和本公司联系 PLS Contact Hairise Confirm Width Before Booking			

链轮 Sprocket	护栏 Guide	其余配件 Component
S20-S23	R01-R42	C01-C57

Har900 Series Flush Grid Dynamic Transition MODULAR BELT

MODULAR BELT 900 Series
P=27.2mm, T=8.8mm
OPEN AREA:38%



节距 Pitch	网链材质 Material	颜色 Color
27.2mm	POM	蓝色/Blue

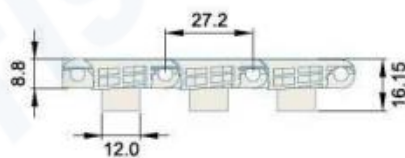
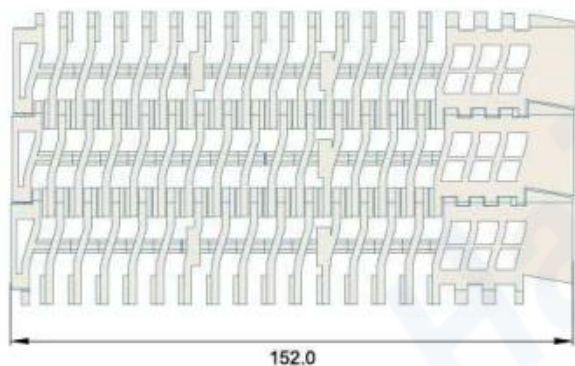

挡板高度 Cleat Height	—	材质 Material	重量 Weight(KG/M)	工作负荷 Working Capacity(N/M)
裙边高度 Side Apron Height	—	POM	0.89	3300
穿销材质 Pin Material	PP/NYLON/PBT DIAMETER:4.6mm	PP	0.58	1600
可选宽度 Available Width 塑料缩水率引致的正常误差; 正负差距 ±3(mm) The normal error caused by the shrinkage of plastic; ±3(mm)				
单片宽度 (Bulk Pieces Width)		组合宽度 (Assemble Width)		
152mm		152mm		
非标宽度 Nonstandard Width		非标定制前请和本公司联系 PLS Contact Hairise Confirm Width Before Booking		

链轮 Sprocket	护栏 Guide	其余配件 Component
S20-S23	R01-R42	C01-C57

Har900 Series Packing Machine Separation Chain A

MODULAR BELT

MODULAR BELT 900 Series
 P=27.2mm, T=14.0mm
 OPEN AREA:38%



节距 Pitch	网链材质 Material	颜色 Color
27.2mm	POM	蓝色/Blue



挡板高度 Cleat Height	—	材质 Material	重量 Weight(KG/M)	工作负荷 Working Capacity(N/M)
裙边高度 Side Apron Height	—	POM	0.38	910
穿销材质 Pin Material	PP	—	—	—
可选宽度 Available Width 塑料缩水率引致的正常误差; 正负差距 ±3(mm) The normal error caused by the shrinkage of plastic; ±3(mm)				
单片宽度 (Bulk Pieces Width)		组合宽度 (Assemble Width)		
35mm		—		
非标宽度 Nonstandard Width		非标定制前请和本公司联系 PLS Contact Hairise Confirm Width Before Booking		

链轮 Sprocket	护栏 Guide	其余配件 Component
S20-S23	R01-R42	C01-C57

Har900 Series Packaging Machine Separation Chain B

MODULAR BELT

MODULAR BELT 900 Series

P=27.2mm, T=14.0mm

OPEN AREA:38%

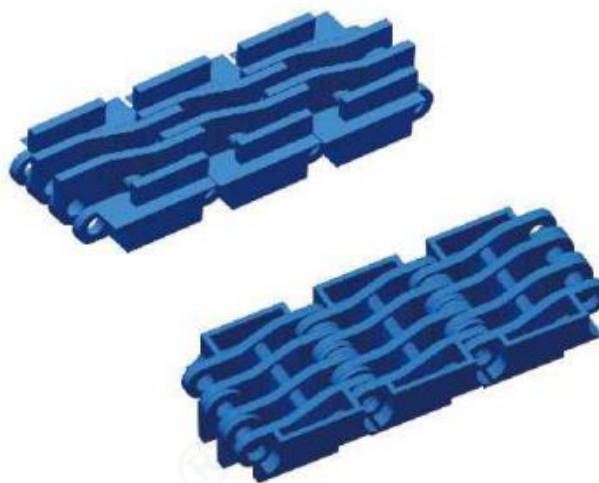

节距 Pitch	网链材质 Material	颜色 Color
27.2mm	POM	蓝色/Blue

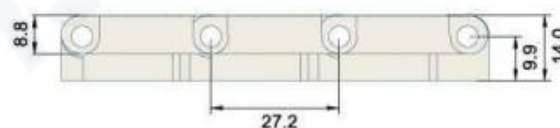
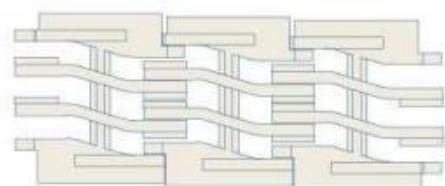

挡板高度 Cleat Height	—	材质 Material	重量 Weight(KG/M)	工作负荷 Working Capacity(N/M)
裙边高度 Side Apron Height	—	POM	0.35	910
穿销材质 Pin Material	PP/NYLON/PBT DIAMETER:4.6mm	—	—	—
可选宽度 Available Width 塑料缩水率引致的正常误差：正负差距 ±3(mm) The normal error caused by the shrinkage of plastic: ±3(mm)				
单片宽度 (Bulk Pieces Width)		组合宽度 (Assemble Width)		
35mm		35mm		
非标宽度 Nonstandard Width		非标定制前请和本公司联系 PLS Contact Hairise Confirm Width Before Booking		

链轮 Sprocket	护栏 Guide	其余配件 Component
S20-S23	R01-R42	C01-C57

Har900 Series Packaging Machine Separation Chain C

MODULAR BELT

MODULAR BELT 900 Series
 P=27.2mm, T=14mm
 OPEN AREA:38%

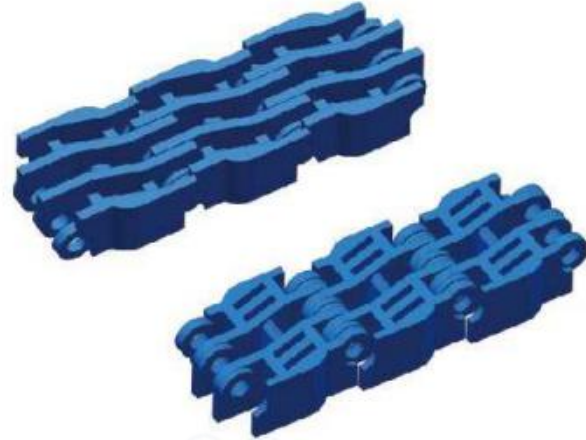

节距 Pitch	网链材质 Material	颜色 Color
27.2mm	POM	蓝色/Blue

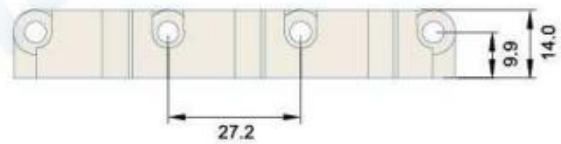
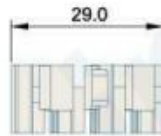

挡板高度 Cleat Height	—	材质 Material	重量 Weight(KG/M)	工作负荷 Working Capacity(N/M)
裙边高度 Side Apron Height	—	POM	0.29	640
穿销材质 Pin Material	PP/NYLON/PBT DIAMETER:4.6mm	—	—	—
可选宽度 Available Width 塑料缩水率引致的正常误差; 正负差距 ±3(mm) The normal error caused by the shrinkage of plastic; ±3(mm)				
单片宽度 (Bulk Pieces Width)		组合宽度 (Assemble Width)		
29mm		29mm		
非标宽度 Nonstandard Width		非标定制前请和本公司联系 PLS Contact Hairise Confirm Width Before Booking		

链轮 Sprocket	护栏 Guide	其余配件 Component
S20-S23	R01-R42	C01-C57

Har900 Series Packaging Machine Separation Chain D

MODULAR BELT

MODULAR BELT 900 Series
 P=27.2mm, T=14.0mm
 OPEN AREA:38%



节距 Pitch	网链材质 Material	颜色 Color
27.2mm	POM	蓝色/Blue

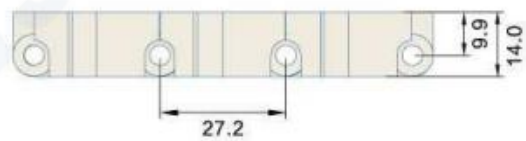
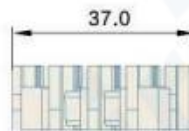
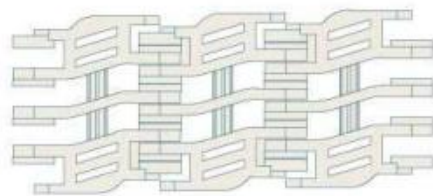

挡板高度 Cleat Height	—	材质 Material	—	重量 Weight(KG/M)	—	工作负荷 Working Capacity(N/M)	—
裙边高度 Side Apron Height	—	POM	—	0.35	—	910	—
穿销材质 Pin Material	PP/NYLON/PBT DIAMETER:4.6mm	—	—	—	—	—	—
可选宽度 Available Width 塑料缩水率引致的正常误差; 正负差距 ±3(mm) The normal error caused by the shrinkage of plastic; ±3(mm)							
单片宽度 (Bulk Pieces Width)				组合宽度 (Assemble Width)			
37mm				37mm			
非标宽度 Nonstandard Width				非标定制前请和本公司联系 PLS Contact Hairise Confirm Width Before Booking			

链轮 Sprocket	护栏 Guide	其余配件 Component
S20-S23	R01-R42	C01-C57

Har900 Series Packaging Machine Separation Chain E

MODULAR BELT

MODULAR BELT 900 Series
 P=27.2mm, T=14.0mm
 OPEN AREA:38%



节距 Pitch	网链材质 Material	颜色 Color
27.2mm	POM	蓝色/Blue

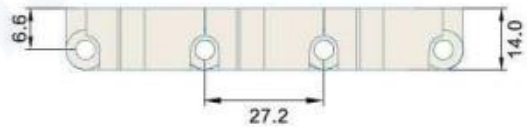
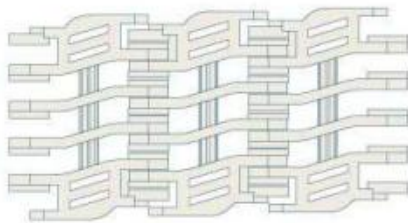

挡板高度 Cleat Height	—	材质 Material	重量 Weight(KG/M)	工作负荷 Working Capacity(N/M)
裙边高度 Side Apron Height	—	POM	0.43	1040
穿销材质 Pin Material	PP/NYLON/PBT DIAMETER:4.6mm	—	—	—
可选宽度 Available Width 塑料缩水率引致的正常误差：正负差距±3(mm) The normal error caused by the shrinkage of plastic; ±3(mm)				
单片宽度 (Bulk Pieces Width)		组合宽度 (Assemble Width)		
46mm		46mm		
非标宽度 Nonstandard Width		非标定制前请和本公司联系 PLS Contact Hairise Confirm Width Before Booking		

链轮 Sprocket	护栏 Guide	其余配件 Component
S20-S23	R01-R42	C01-C57

Har900 Series Flat Top With Positrack MODULAR BELT

MODULAR BELT 900 Series
P=27.2mm, T=9.8mm
OPEN AREA:0%

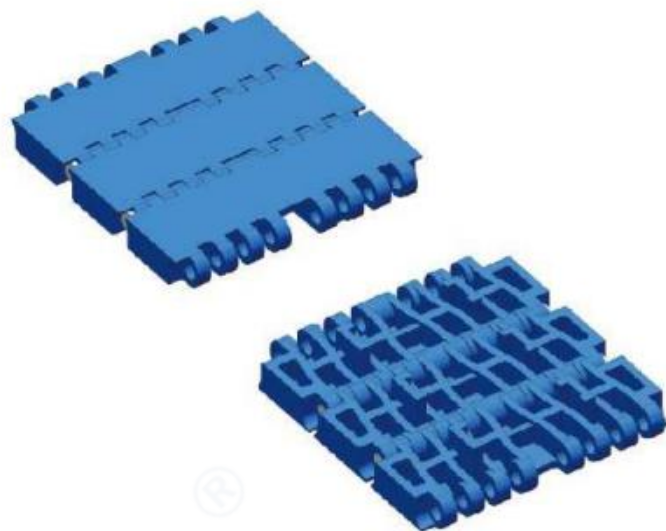

节距 Pitch	网链材质 Material	颜色 Color
27.2mm	POM	蓝色/Blue
27.2mm	PP	蓝色/Blue

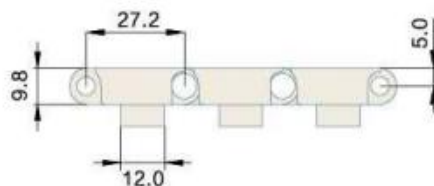
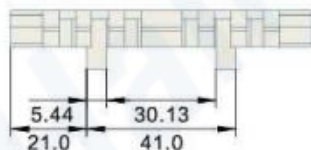
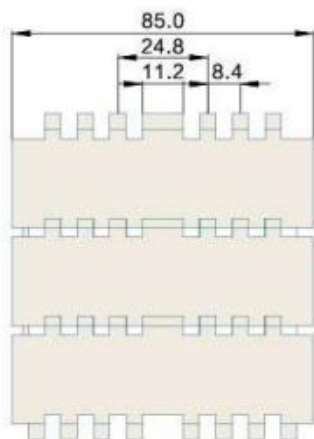

挡板高度 Cleat Height	—	材质 Material	重量 Weight(KG/M)	工作负荷 Working Capacity(N/M)
裙边高度 Side Apron Height	—	POM	0.77	1130
穿销材质 Pin Material	PP/NYLON/PBT	PP	0.55	590

可选宽度 Available Width

塑料缩水率引致的正常误差；正负差距 ±3(mm) The normal error caused by the shrinkage of plastic; ±3(mm)

单片宽度 (Bulk Pieces Width)	组合宽度 (Assemble Width)
85mm	85mm
非标宽度 Nonstandard Width	非标定制前请和本公司联系 PLS Contact Hairise Confirm Width Before Booking

链轮 Sprocket	护栏 Guide	其余配件 Component
S20-S23	R01-R42	C01-C57

Har900 Series Flat Top

MODULAR BELT (NEW TYPE)

MODULAR BELT 900 Series
P=27.2mm, T=9.8mm

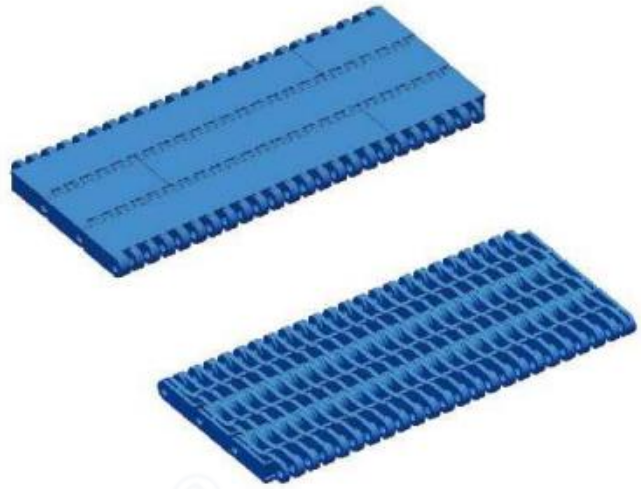

节距 Pitch	网链材质 Material	颜色 Color
27.2mm	POM	蓝色/Blue
27.2mm	PP	灰色/Grey

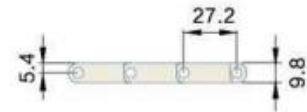
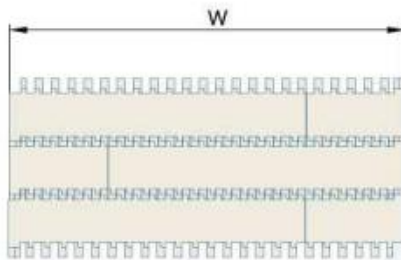

挡板高度 Cleat Height	32/50mm	材质 Material	POM	重量 Weight(KG/SQ)	7.3	工作负荷 Working Capacity(N/M)	10400
裙边高度 Side Apron Height	—						
穿销材质 Pin Material	PP/NYLON/PBT DIAMETER:4.6mm	PP		5.5		22000	
可选宽度 Available Width 塑料缩水率引致的正常误差：正负差距 ±3(mm) The normal error caused by the shrinkage of plastic; ±3(mm)							
单片宽度 (Bulk Pieces Width)				组合宽度 (Assemble Width)			
50mm	152mm	143mm	143+50+152*N				
非标宽度 Nonstandard Width				非标定制前请和本公司联系 PLS Contact Hairise Confirm Width Before Booking			

链轮 Sprocket	护栏 Guide	其余配件 Component
S20-S23	R01-R42	C01-C57

Har900 Series Flush Grid

MODULAR BELT

MODULAR BELT 900 Series

P=27.2mm, T=8.8mm

OPEN AREA:38%



节距 Pitch	网链材质 Material	颜色 Color
27.2mm	PP	灰色/Grey
	POM	蓝色/Blue 深蓝/Dark Blue 墨绿/Dark Green

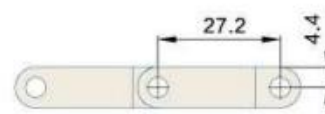
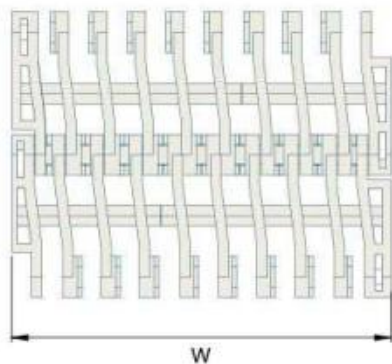

挡板高度 Cleat Height	32/50mm	材质 Material	重量 Weight(KG/SQ)	工作负荷 Working Capacity(N/M)
裙边高度 Side Apron Height	—	PP	4.54	10400
穿销材质 Pin Material	PP/NYLON/PBT	POM	6.50	22000

可选宽度 Available Width

塑料缩水率引致的正常误差：正负差距 ±3(mm) The normal error caused by the shrinkage of plastic; ±3(mm)

单片宽度 (Bulk Pieces Width)			组合宽度 (Assemble Width)
50mm	143mm	152mm	50+143+152*N
非标宽度 Nonstandard Width			非标定制前请和本公司联系 PLS Contact Hairise Confirm Width Before Booking

链轮 Sprocket	护栏 Guide	其余配件 Component
S20-S23	R01-R42	C01-C57

Har900N Series Flush Grid MODULAR BELT

MODULAR BELT 900N Series
P=27.2mm, T=8.7mm
OPEN AREA:43%

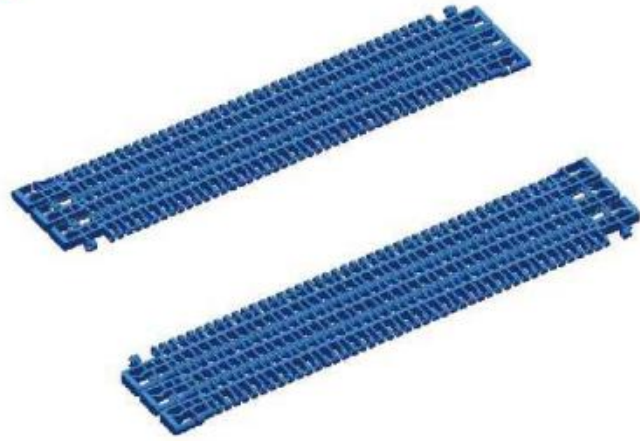

节距 Pitch	网链材质 Material	颜色 Color
27.2mm	POM	蓝色/Blue
27.2mm	PP	灰色/Grey

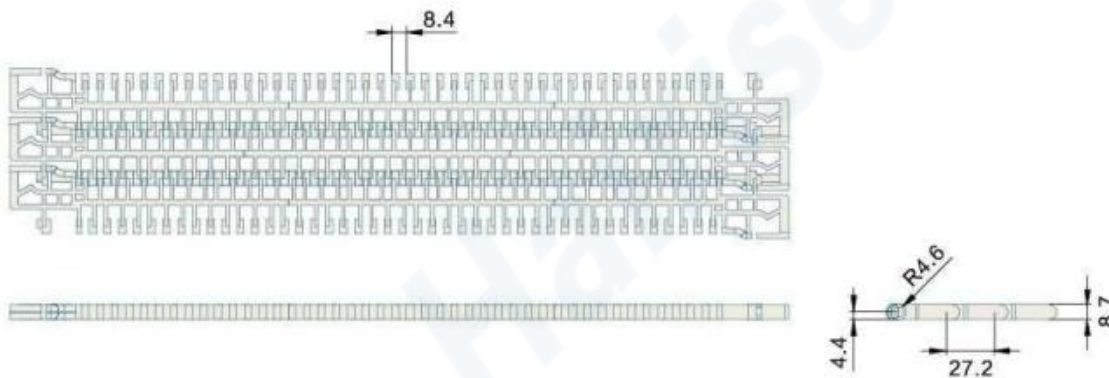

挡板高度 Cleat Height	—	材质 Material	重量 Weight(KG/SQ)	工作负荷 Working Capacity(N/M)
裙边高度 Side Apron Height	—	POM	5.37	22000
穿销材质 Pin Material	PP/NYLON/PBT DIAMETER:4.6mm	PP	3.71	10400
可选宽度 Available Width 塑料缩水率引致的正常误差：正负差距 ±3(mm) The normal error caused by the shrinkage of plastic: ±3(mm)				
单片宽度 (Bulk Pieces Width)			组合宽度 (Assemble Width)	
135mm	152mm	160mm	160+135+152*N	
非标宽度 Nonstandard Width			非标定制前请和本公司联系 PLS Contact Hairise Confirm Width Before Booking	

链轮 Sprocket	护栏 Guide	其余配件 Component
—	R01-R42	C01-C57

Har7920 Series Flush Grid

MODULAR BELT

MODULAR BELT 7920 Series

P=27.9mm, T=11mm

OPEN AREA:66%

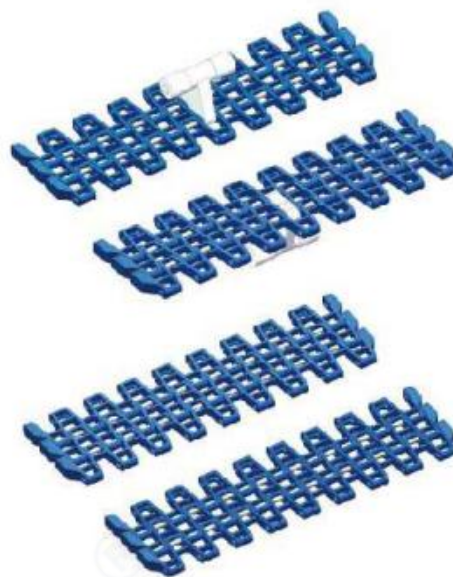

节距 Pitch	网链材质 Material	颜色 Color
27.9mm	POM	蓝色/Blue

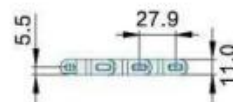
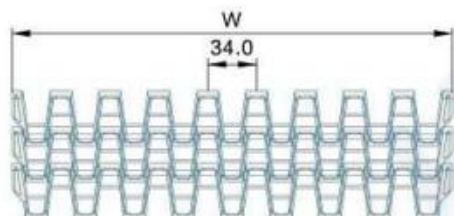
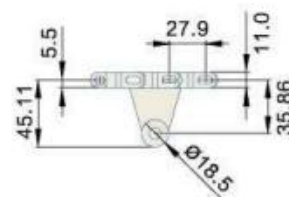
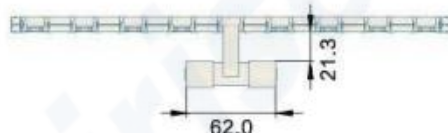
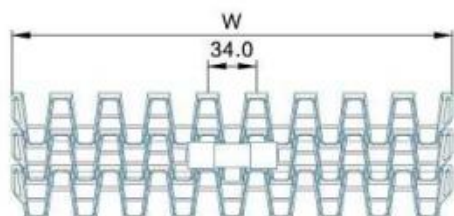

挡板高度 Cleat Height	—	材质 Material	重量 Weight(KG/SQ)	工作负荷 Working Capacity(N/M)
裙边高度 Side Apron Height	—	POM	8.0	12000
穿销材质 Pin Material	PP/NYLON/PBT DIAMETER:4mm	—	—	—
可选宽度 Available Width 塑料缩水率引致的正常误差：正负差距±3(mm) The normal error caused by the shrinkage of plastic: ±3(mm)				
单片宽度 (Bulk Pieces Width)		组合宽度 (Assemble Width)		
306mm		306mm+35*N		
非标宽度 Nonstandard Width		非标定制前请和本公司联系 PLS Contact Hairise Confirm Width Before Booking		

链轮 Sprocket	护栏 Guide	其余配件 Component
S59	R01-R42	C01-C57

Har7960 Series Flush Grid MODULAR BELT

MODULAR BELT 7960 Series
P=38.1mm, T=15mm
OPEN AREA:58%

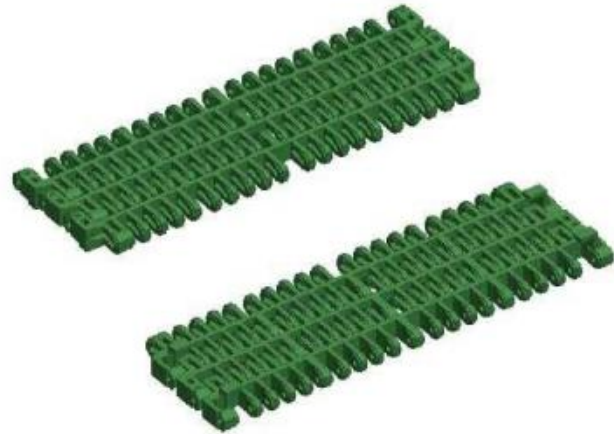

节距 Pitch	网链材质 Material	颜色 Color	转弯系数 Turn Radius
38.1mm	POM	绿色/Green	2.5

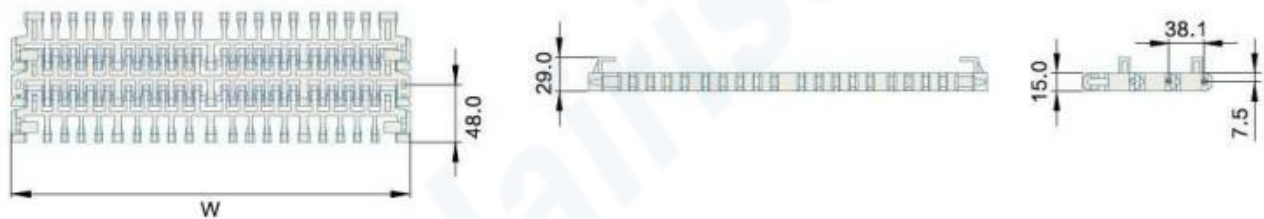

挡板高度 Cleat Height	—	材质 Material	重量 Weight(KG/SQ)	工作负荷 Working Capacity(N/M)
裙边高度 Side Apron Height	—	POM	8.8	21000
穿销材质 Pin Material	PP/NYLON/PBT DIAMETER:4.6mm	—	—	—
可选宽度 Available Width 塑料缩水率引起的正常误差：正负差距 ±3(mm) The normal error caused by the shrinkage of plastic: ±3(mm)				
单片宽度 (Bulk Pieces Width)		组合宽度 (Assemble Width)		
330mm		330*N		
非标宽度 Nonstandard Width		非标定制前请和本公司联系 PLS Contact Hairise Confirm Width Before Booking		

链轮 Sprocket	护栏 Guide	其余配件 Component
S61	R01-R42	C01-C57

Har7960 Series Rubber Top MODULAR BELT

MODULAR BELT 7960 Series
P=38.1mm, T=15mm
OPEN AREA:58%

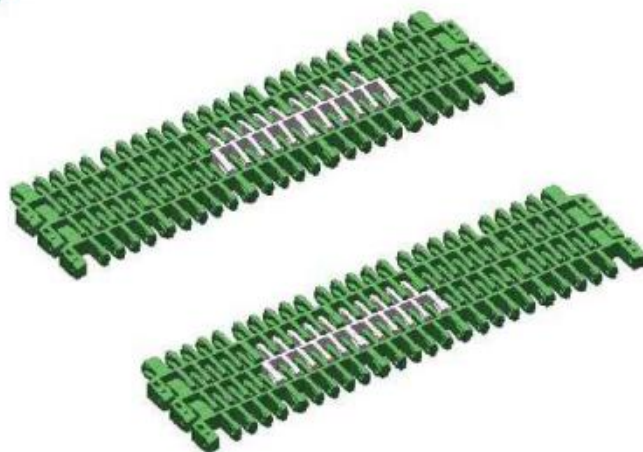

节距 Pitch	网链材质 Material	颜色 Color	转弯系数 Turn Radius
38.1mm	POM	绿底白胶/ Green Plate White Rubber	2.5

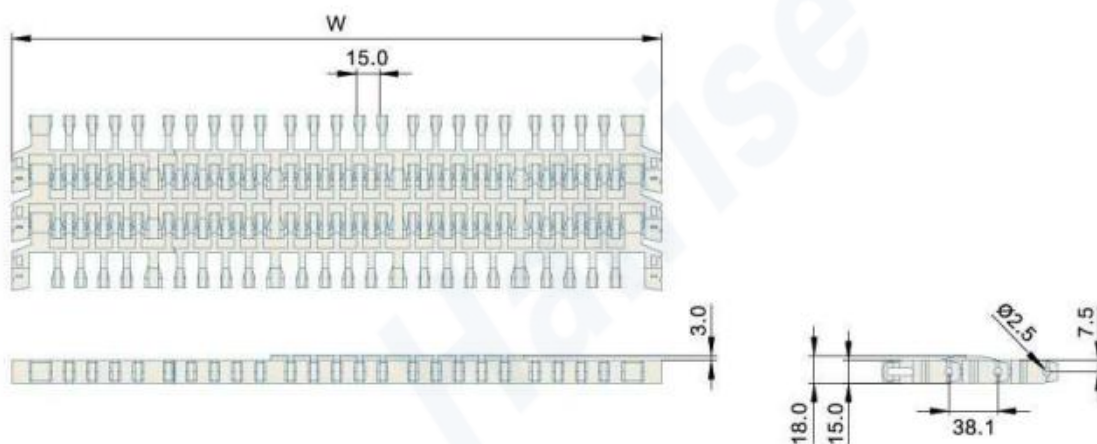

挡板高度 Cleat Height	—	材质 Material	重量 Weight(KG/SQ)	工作负荷 Working Capacity(N/M)
裙边高度 Side Apron Height	—	PP	8.5	12000
穿销材质 Pin Material	PP/NYLON/PBT DIAMETER:4.6mm	—	—	—
可选宽度 Available Width 塑料缩水率引致的正常误差：正负差距 ±3(mm) The normal error caused by the shrinkage of plastic; ±3(mm)				
单片宽度 (Bulk Pieces Width)		组合宽度 (Assemble Width)		
330mm		330*N		
非标宽度 Nonstandard Width		非标定制前请和本公司联系 PLS Contact Hairise Confirm Width Before Booking		

链轮 Sprocket	护栏 Guide	其余配件 Component
S61	R01-R42	C01-C57

Har7960 Series Pusher MODULAR BELT

MODULAR BELT 7960 Series
P=38.1mm, T=15mm
OPEN AREA:56%

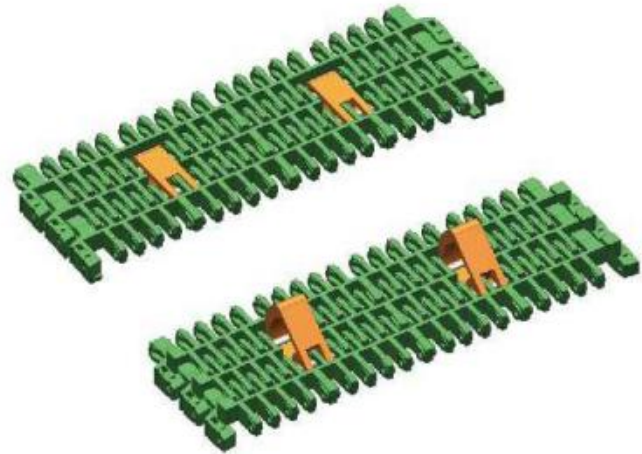

节距 Pitch	网链材质 Material	颜色 Color	转弯系数 Turn Radius
38.1mm	POM	绿色/Green	2.5

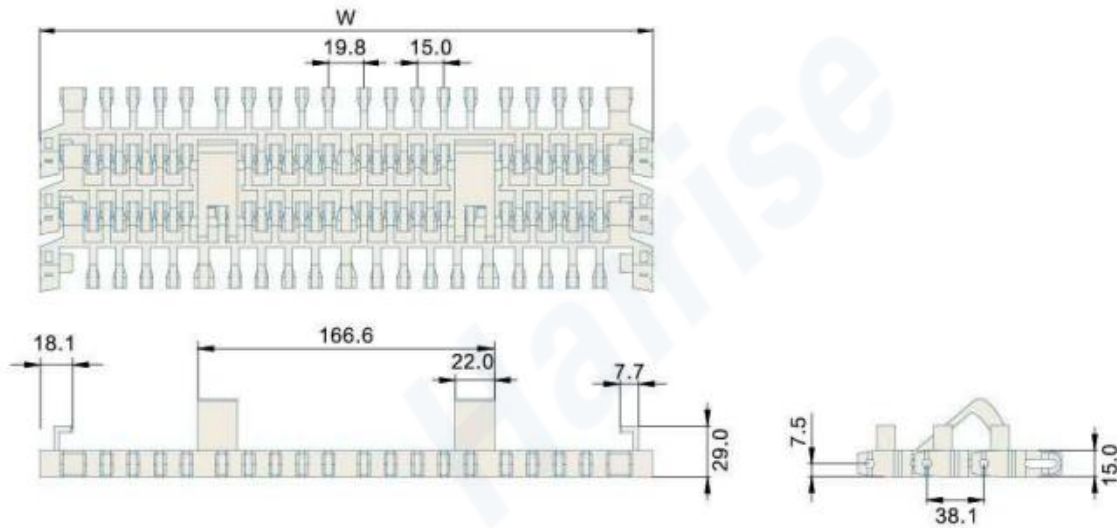

挡板高度 Cleat Height	—	材质 Material	重量 Weight(KG/SQ)	工作负荷 Working Capacity(N/M)
裙边高度 Side Apron Height	—	POM	—	—
穿销材质 Pin Material	PP/NYLON/PBT DIAMETER:4.6mm	—	—	—
可选宽度 Available Width 塑料缩水率引致的正常误差：正负差距±3(mm) The normal error caused by the shrinkage of plastic: ±3(mm)				
单片宽度 (Bulk Pieces Width)		组合宽度 (Assemble Width)		
330mm		330*N		
非标宽度 Nonstandard Width		非标定制前请和本公司联系 PLS Contact Hairise Confirm Width Before Booking		

链轮 Sprocket	护栏 Guide	其余配件 Component
S61	R01-R42	C01-C57

Har2265 Series Flush Grid With Positrack MODULAR BELT

MODULAR BELT 2265 Series
P=31.75mm, T=12.7mm
OPEN AREA:39%

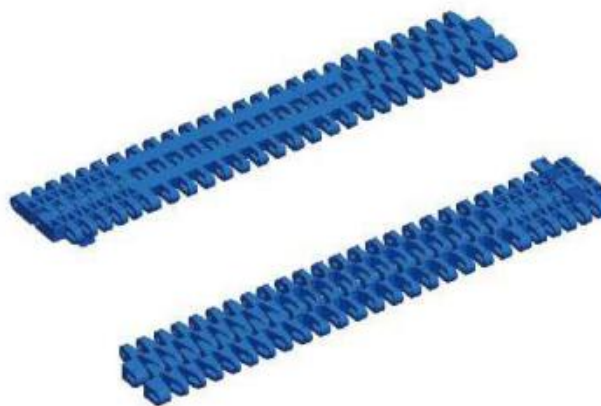

节距 Pitch	网链材质 Material	颜色 Color	转弯系数 Turn Radius
31.75mm	POM	墨绿色/ Dark Green	1.8
31.75mm	PP	墨绿色/ Dark Green	1.8

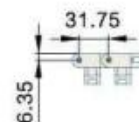
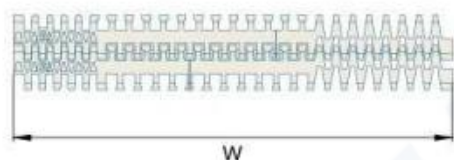

挡板高度 Cleat Height	—	材质 Material	重量 Weight(KG/SQ)	工作负荷 Working Capacity(N/M)
裙边高度 Side Apron Height	—	POM	8.1	25000
穿销材质 Pin Material	PP/NYLON/PBT DIAMETER:5mm	PP	8.0	25000
可选宽度 Available Width 塑料缩水率引致的正常误差: 正负差距 ±3(mm) The normal error caused by the shrinkage of plastic: ±3(mm)				
单片宽度 (Bulk Pieces Width)			组合宽度 (Assemble Width)	
170mm	170mm	255mm	425mm+85mm*N	
非标宽度 Nonstandard Width			非标定制前请和本公司联系 PLS Contact Hairise Confirm Width Before Booking	

链轮 Sprocket	护栏 Guide	其余配件 Component
S40	R01-R42	C01-C57

Har2275 Series Turning Type With Bearing

MODULAR BELT

MODULAR BELT 2275 Series
 P=31.75mm, T=12.7mm
 OPEN AREA:39%



节距 Pitch	网链材质 Material	颜色 Color	转弯系数 Turn Radius
31.75mm	POM	灰色/Grey	1.8

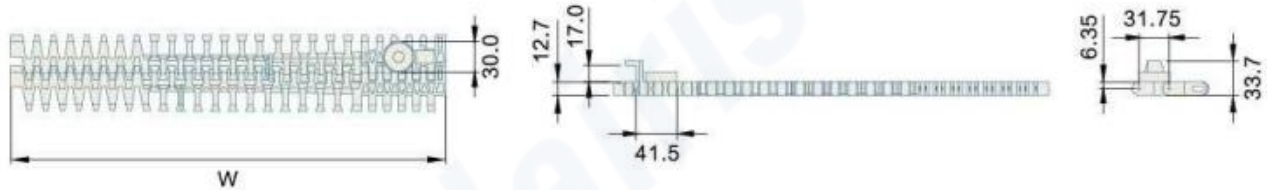

挡板高度 Cleat Height	—	材质 Material	重量 Weight(KG/SQ)	工作负荷 Working Capacity(N/M)
裙边高度 Side Apron Height	—	POM	8.0	25000
穿销材质 Pin Material	PP/NYLON/PBT DIAMETER: 5mm	PP	5.2	16000
可选宽度 Available Width 塑料缩水率引致的正常误差：正负差距 ±3(mm) The normal error caused by the shrinkage of plastic: ±3(mm)				
单片宽度 (Bulk Pieces Width)			组合宽度 (Assemble Width)	
170mm	170mm	255mm	425mm+85mm*N	
非标宽度 Nonstandard Width			非标定制前请和本公司联系 PLS Contact Hairise Confirm Width Before Booking	

链轮 Sprocket	护栏 Guide	其余配件 Component
S40	R01-R42	C01-C57

Har2300 Series Flush Grid Turning MODULAR BELT

MODULAR BELT 2300 Series
 P=38.1mm, T=18.8mm
 OPEN AREA:50%



节距 Pitch	网链材质 Material	颜色 Color	转弯系数 Turn Radius
38.1mm	PP	白色/White	2.5



挡板高度 Cleat Height	—	材质 Material	重量 Weight(KG/SQ)	工作负荷 Working Capacity(N/M)
裙边高度 Side Apron Height	—	PP	9.1	23800
穿销材质 Pin Material	PP/NYLON/PBT DIMAETER:6mm	—	—	—
可选宽度 Available Width 塑料缩水率引致的正常误差：正负差距 ±3(mm) The normal error caused by the shrinkage of plastic: ±3(mm)				
单片宽度 (Bulk Pieces Width)		组合宽度 (Assemble Width)		
120mm	207mm	120+207+25mm*N		
非标宽度 Nonstandard Width		非标定制前请和本公司联系 PLS Contact Hairise Confirm Width Before Booking		

链轮 Sprocket	护栏 Guide	其余配件 Component
—	R01-R42	C01-C57

Har3811GB Series Flat Top MODULAR BELT

MODULAR BELT 3811GB Series
P=38.1mm, T=19.1mm
OPEN AREA:17%



节距 Pitch	网链材质 Material	颜色 Color
38.1mm	POM	蓝色/Blue

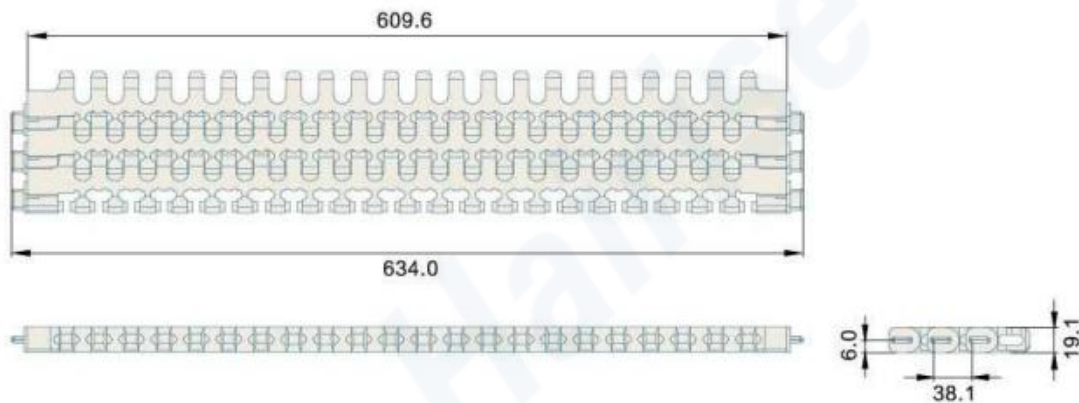

挡板高度 Cleat Height	—	材质 Material	重量 Weight(KG/SQ)	工作负荷 Working Capacity(N/M)
裙边高度 Side Apron Height	—	POM	14	38600
穿销材质 Pin Material	—	—	—	—
可选宽度 Available Width 塑料缩水率引致的正常误差: 正负差距 ±3(mm) The normal error caused by the shrinkage of plastic: ±3(mm)				
单片宽度 (Bulk Pieces Width)		组合宽度 (Assemble Width)		
609.6mm		609.6mm		
非标宽度 Nonstandard Width		非标定制前请和本公司联系 PLS Contact Hairise Confirm Width Before Booking		

链轮 Sprocket	护栏 Guide	其余配件 Component
—	R01-R42	C01-C57

Har1700T Series MODULAR BELT

MODULAR BELT 1700T Series
P=38.1mm, T=19.0mm
OPEN AREA:42%

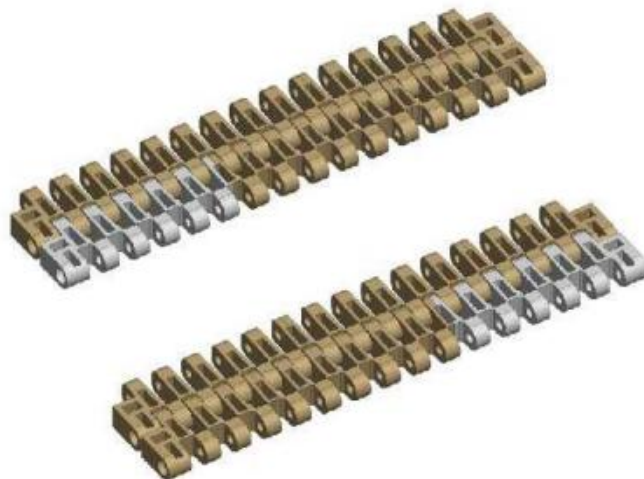

节距 Pitch	网链材质 Material	颜色 Color
38.1mm	PP	浅黄色/Light Yellow

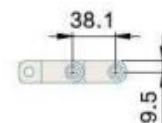
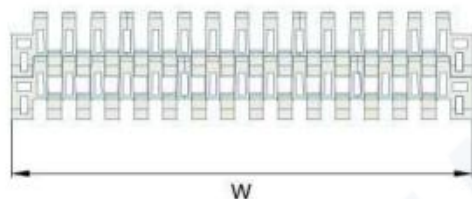

挡板高度 Cleat Height	76mm	材质 Material	重量 Weight(KG/SQ)	工作负荷 Working Capacity(N/M)
裙边高度 Side Apron Height	—	PP	8.0	13400
穿销材质 Pin Material	PP/NYLON/PBT DIMAETER:7.5mm	—	—	—
可选宽度 Available Width 塑料缩水率引致的正常误差：正负差距 ±3(mm) The normal error caused by the shrinkage of plastic: ±3(mm)				
单片宽度 (Bulk Pieces Width)		组合宽度 (Assemble Width)		
101mm	151mm	101+151+25mm*N		
非标宽度 Nonstandard Width		非标定制前请和本公司联系 PLS Contact Hairise Confirm Width Before Booking		

链轮 Sprocket	护栏 Guide	其余配件 Component
S35	R01-R42	C01-C57

Har1700T Series Nub Top MODULAR BELT

MODULAR BELT 1700T Series
P=38.1mm, T=19mm
OPEN AREA:37%

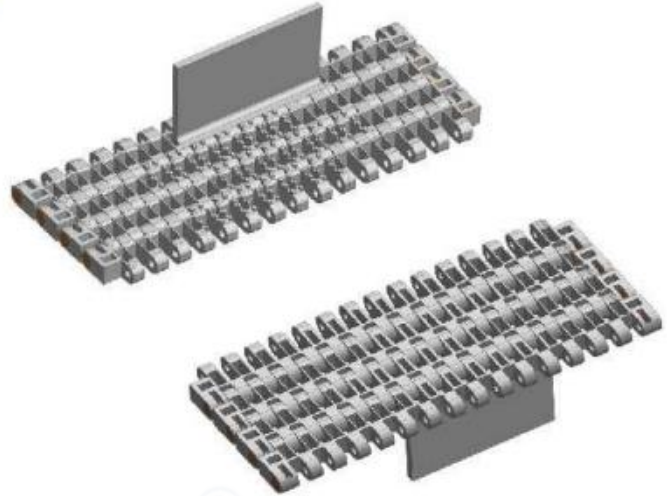

节距 Pitch	网链材质 Material	颜色 Color
38.1 mm	PP	淡黄色/Pale Yellow

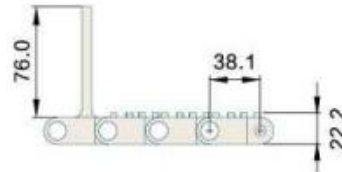
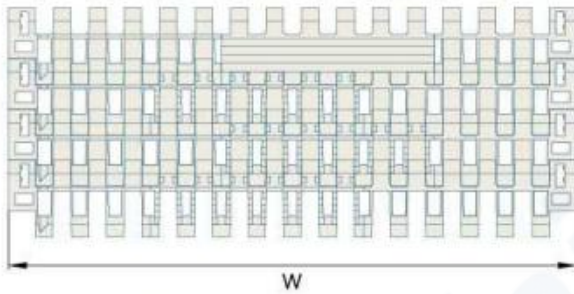

挡板高度 Cleat Height	76mm	材质 Material	PP	重量 Weight(KG/SQ)	10.78	工作负荷 Working Capacity(N/M)	22100
裙边高度 Side Apron Height	—	—	—	—	—	—	—
穿销材质 Pin Material	PP/NYLON/PBT DIAMETER:7.5mm	—	—	—	—	—	—

可选宽度 Available Width

塑料缩水率引致的正常误差：正负差距 ±3(mm) The normal error caused by the shrinkage of plastic; ±3(mm)

单片宽度 (Bulk Pieces Width)		组合宽度 (Assemble Width)
101mm	151mm	101+151+25*N
非标宽度 Nonstandard Width		非标定制前请和本公司联系 PLS Contact Hairise Confirm Width Before Booking

链轮 Sprocket	护栏 Guide	其余配件 Component
S35	R01-R42	C01-C57

Har4705 Series Flat Top MODULAR BELT

MODULAR BELT 4705 Series
P=38.1mm, T=12.7mm
OPEN AREA:0%

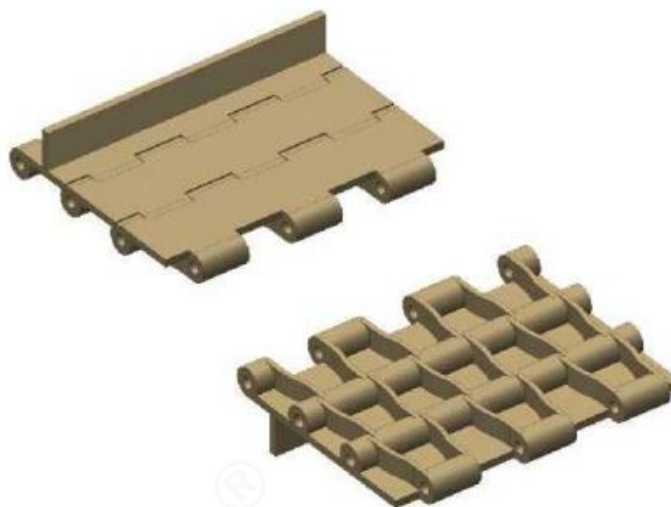

节距 Pitch	网链材质 Material	颜色 Color
38.1mm	POM	棕色/Brown

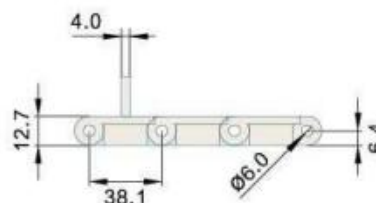
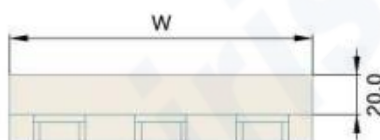
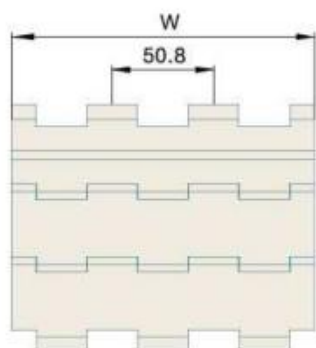

挡板高度 Cleat Height	20mm	材质 Material	重量 Weight(KG/SQ)	工作负荷 Working Capacity(N/M)
裙边高度 Side Apron Height	—	POM	9.2	18000
穿销材质 Pin Material	PP/NYLON/PBT DIAMETER:6mm	—	—	—
可选宽度 Available Width 塑料缩水率引致的正常误差：正负差距 ±3(mm) The normal error caused by the shrinkage of plastic: ±3(mm)				
单片宽度 (Bulk Pieces Width)		组合宽度 (Assemble Width)		
151mm		151*N		
非标宽度 Nonstandard Width		非标定制前请和本公司联系 PLS Contact Hairise Confirm Width Before Booking		

链轮 Sprocket	护栏 Guide	其余配件 Component
—	R01-R42	C01-C57

Har4705 Series Perforated Top MODULAR BELT

MODULAR BELT 4705 Series
P=38.1mm, T=12.7mm
OPEN AREA:9%

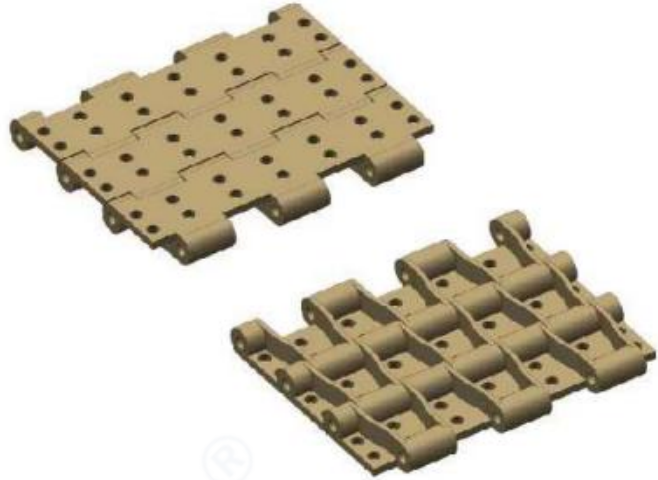

节距 Pitch	网链材质 Material	颜色 Color
38.1mm	POM	棕色/Brown

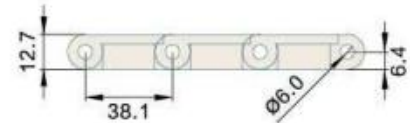
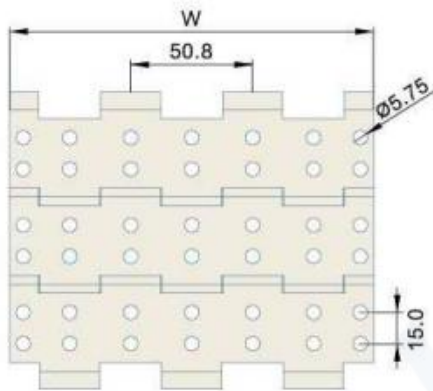

挡板高度 Cleat Height	—	材质 Material	重量 Weight(KG/SQ)	工作负荷 Working Capacity(N/M)
裙边高度 Side Apron Height	—	POM	9.08	17000
穿销材质 Pin Material	PP/NYLON/PBT DIAMETER:6mm	—	—	—

可选宽度 Available Width

塑料缩水率引致的正常误差：正负差距 ±3(mm) The normal error caused by the shrinkage of plastic; ±3(mm)

单片宽度 (Bulk Pieces Width)	组合宽度 (Assemble Width)
151mm	151*N
非标宽度 Nonstandard Width	非标定制前请和本公司联系 PLS Contact Hairise Confirm Width Before Booking

链轮 Sprocket	护栏 Guide	其余配件 Component
—	R01-R42	C01-C57

Har4707 Series Raised Rib MODULAR BELT

MODULAR BELT 4707 Series
P=38.1mm, T=19.1mm
OPEN AREA:23%

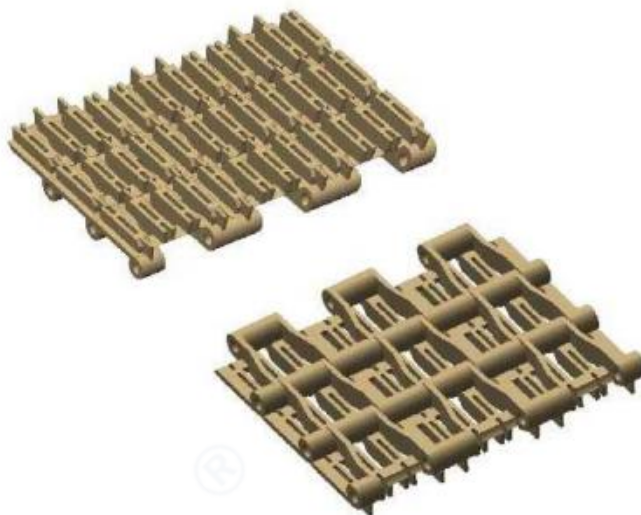

节距 Pitch	网链材质 Material	颜色 Color
38.1mm	PP	白色/White
	PP	棕色/Brown

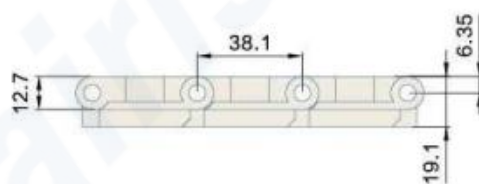
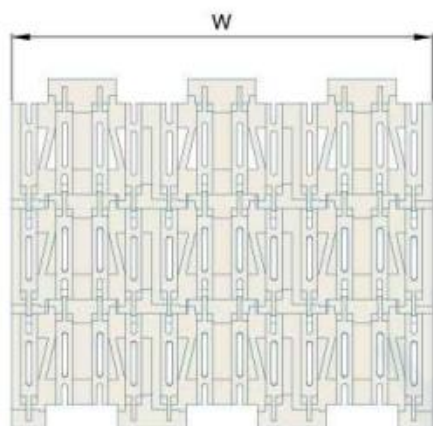

挡板高度 Cleat Height	—	材质 Material	重量 Weight(KG/SQ)	工作负荷 Working Capacity(N/M)
裙边高度 Side Apron Height	—	PP	6.93	8754
穿销材质 Pin Material	PP/NYLON/PBT DIAMETER:6mm	—	—	—
可选宽度 Available Width 塑料缩水率引致的正常误差：正负差距 ±3(mm) The normal error caused by the shrinkage of plastic: ±3(mm)				
单片宽度 (Bulk Pieces Width)		组合宽度 (Assemble Width)		
152mm		76*N		
非标宽度 Nonstandard Width		非标定制前请和本公司联系 PLS Contact Hairise Confirm Width Before Booking		

链轮 Sprocket	护栏 Guide	其余配件 Component
—	R01-R42	C01-C57

Har5966 Series Flush Grid MODULAR BELT

MODULAR BELT 5966 Series
P=38.1mm, T=12.6mm
OPEN AREA:32%

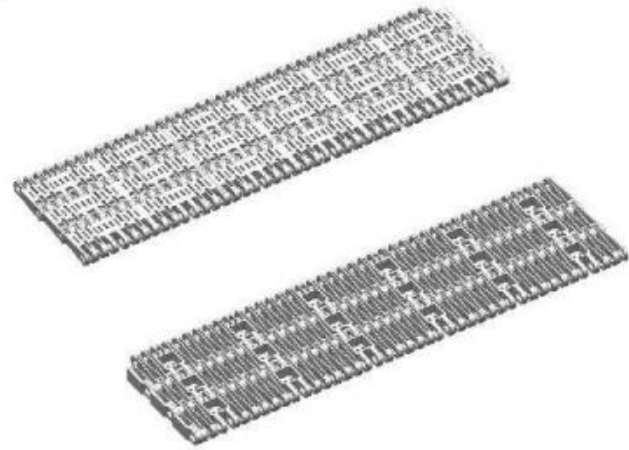

节距 Pitch	网链材质 Material	颜色 Color
38.1mm	PP	白色/White

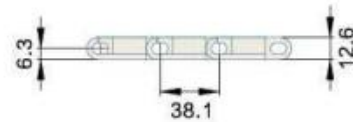
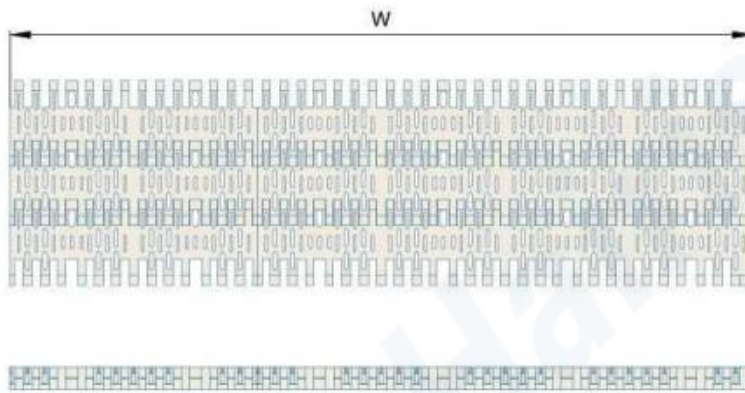

挡板高度 Cleat Height	—	材质 Material	重量 Weight(KG/SQ)	工作负荷 Working Capacity(N/M)
裙边高度 Side Apron Height	—	PP	7.0	25000
穿销材质 Pin Material	PP/NYLON/PBT DIAMETER:6mm	—	—	—
可选宽度 Available Width 塑料缩水率引致的正常误差: 正负差距 ±3(mm) The normal error caused by the shrinkage of plastic: ±3(mm)				
单片宽度 (Bulk Pieces Width)		组合宽度 (Assemble Width)		
151mm	304mm	455+76*N		
非标宽度 Nonstandard Width		非标定制前请和本公司联系 PLS Contact Hairise Confirm Width Before Booking		

链轮 Sprocket	护栏 Guide	其余配件 Component
S52	R01-R42	C01-C57

Har7800 Series Flush Grid MODULAR BELT

MODULAR BELT 7800 Series
P=38.1mm, T=10mm
OPEN AREA:28%



节距 Pitch	网链材质 Material	颜色 Color
38.1mm	PP	白色/White 蓝色/Blue

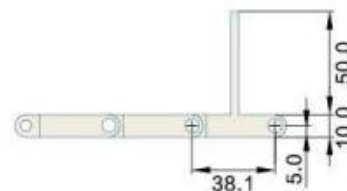
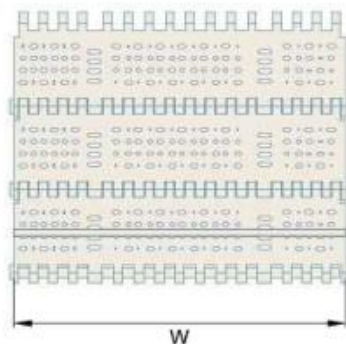

挡板高度 Cleat Height	20/30/50mm	材质 Material	PP	重量 Weight(KG/SQ)	5.8	工作负荷 Working Capacity(N/M)	7800
裙边高度 Side Apron Height	—	—	—	—	—	—	—
穿销材质 Pin Material	PP/NYLON/PBT DIAMETER:4.6mm	—	—	—	—	—	—
可选宽度 Available Width 塑料缩水率引致的正常误差：正负差距 ±3(mm) The normal error caused by the shrinkage of plastic; ±3(mm)							
单片宽度 (Bulk Pieces Width)		组合宽度 (Assemble Width)					
152mm		152+76*N					
非标宽度 Nonstandard Width		非标定制前请和本公司联系 PLS Contact Hairise Confirm Width Before Booking					

链轮 Sprocket	护栏 Guide	其余配件 Component
S58	R01-R42	C01-C57

Har2200 Series Flush Grid MODULAR BELT

MODULAR BELT 2200 Series
P=46mm, T=15mm
OPEN AREA:50%

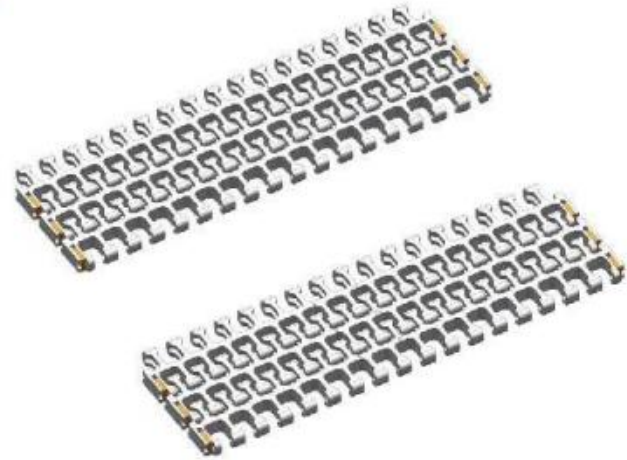

节距 Pitch	网链材质 Material	颜色 Color	转弯系数 Turn Radius
46mm	POM	白色/White	2.5

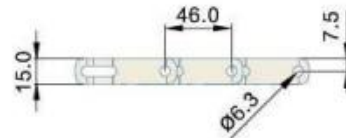
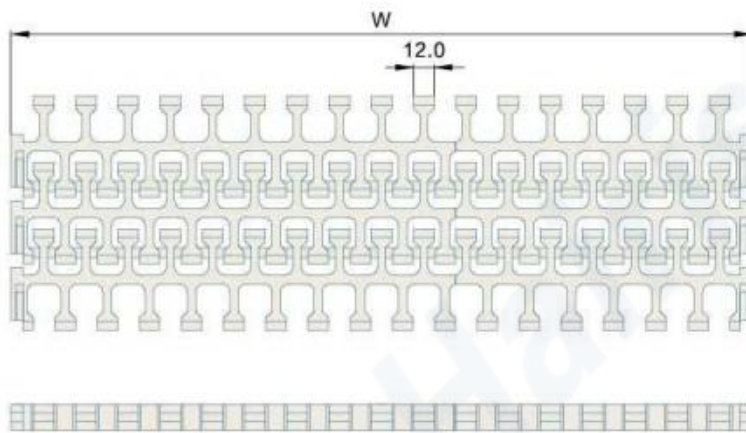

挡板高度 Cleat Height	—	材质 Material	重量 Weight(KG/SQ)	工作负荷 Working Capacity(N/M)
裙边高度 Side Apron Height	—	POM	13.8	28200
穿销材质 Pin Material	PP/NYLON/PBT DIAMETER:6mm	—	—	—
可选宽度 Available Width 塑料缩水率引起的正常误差：正负差距±3(mm) The normal error caused by the shrinkage of plastic; ±3(mm)				
单片宽度 (Bulk Pieces Width)		组合宽度 (Assemble Width)		
90mm	198mm	140mm	—	
非标宽度 Nonstandard Width		非标定制前请和本公司联系 PLS Contact Hairise Confirm Width Before Booking		

链轮 Sprocket	护栏 Guide	其余配件 Component
S39	R01-R42	C01-C57

Har7500 Series Flush Grid

MODULAR BELT

MODULAR BELT 7500 Series

P=50.8mm, T=16mm

OPEN AREA:37%



节距 Pitch	网链材质 Material	颜色 Color
50.8mm	POM	白色/White
	PP	白色/White

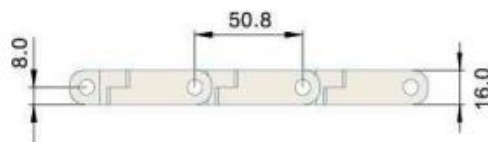
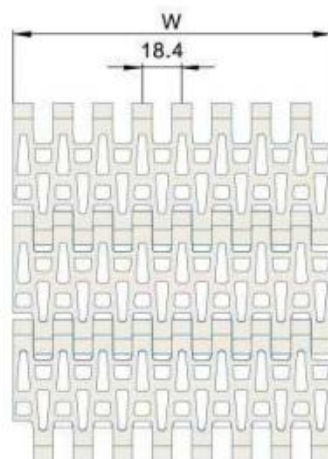

挡板高度 Cleat Height	50mm	材质 Material	重量 Weight(KG/SQ)	工作负荷 Working Capacity(N/M)
裙边高度 Side Apron Height	—	POM	10.5	35000
穿销材质 Pin Material	PP/NYLON/PBT DIAMETER:6mm	PP	7.0	26000

可选宽度 Available Width

塑料缩水率引致的正常误差：正负差距 ±3(mm) The normal error caused by the shrinkage of plastic; ±3(mm)

单片宽度 (Bulk Pieces Width)	组合宽度 (Assemble Width)
149mm	75*N
非标宽度 Nonstandard Width	非标定制前请和本公司联系 PLS Contact Hairise Confirm Width Before Booking

链轮 Sprocket	护栏 Guide	其余配件 Component
S57	R01-R42	C01-C57

Har7501 Series Flush Grid MODULAR BELT

MODULAR BELT 7501 Series
P=50.8mm, T=16mm
OPEN AREA:34%



节距 Pitch	网链材质 Material	颜色 Color
50.8mm	PP	白色/White

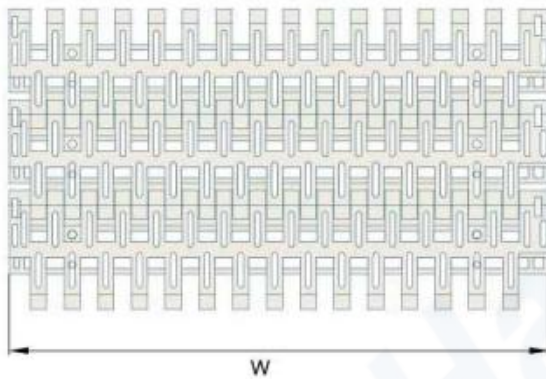

挡板高度 Cleat Height	—	材质 Material	重量 Weight(KG/SQ)	工作负荷 Working Capacity(N/M)
裙边高度 Side Apron Height	—	PP	8.0	36000
穿销材质 Pin Material	PP/NYLON/PBT DIAMETER:6mm	—	—	—
可选宽度 Available Width 塑料缩水率引致的正常误差：正负差距 ±3(mm) The normal error caused by the shrinkage of plastic: ±3(mm)				
单片宽度 (Bulk Pieces Width)		组合宽度 (Assemble Width)		
304mm		304*N		
非标宽度 Nonstandard Width		非标定制前请和本公司联系 PLS Contact Hairise Confirm Width Before Booking		

链轮 Sprocket	护栏 Guide	其余配件 Component
—	R01-R42	C01-C57

Har200 Series Flush Grid MODULAR BELT

MODULAR BELT 200 Series
P=50.8mm, T=16mm
OPEN AREA:38%

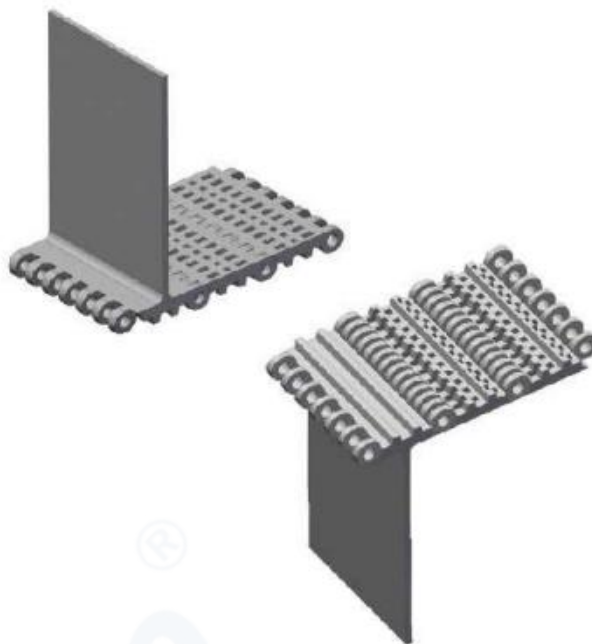

节距 Pitch	网链材质 Material	颜色 Color
50.8mm	PP	白色/White
50.8mm	PP	蓝色/Blue

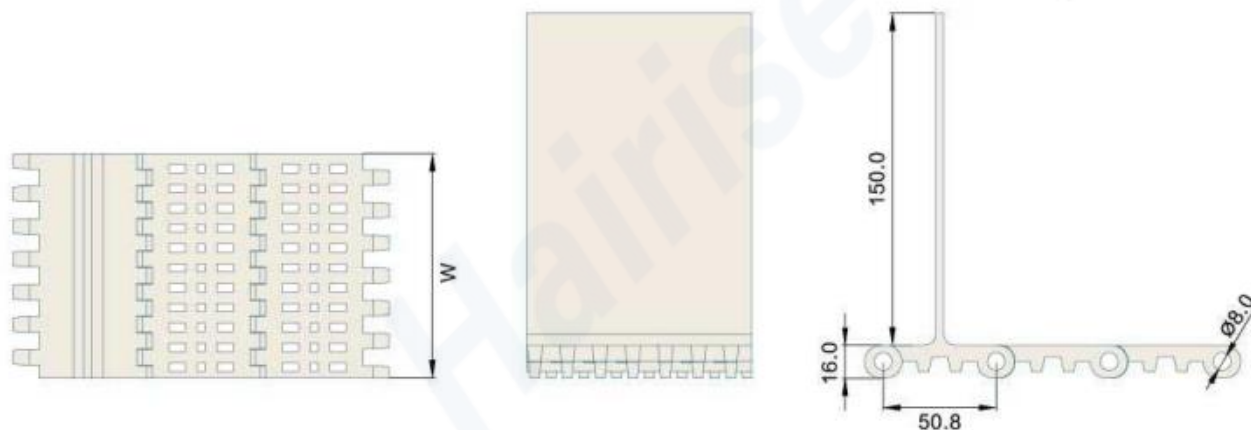

挡板高度 Cleat Height	150mm	材质 Material	PP	重量 Weight(KG/SQ)	7.5	工作负荷 Working Capacity(N/M)	13400
裙边高度 Side Apron Height	130mm						
穿销材质 Pin Material	PP/NYLON/PBT DIAMETER:6mm	—	—	—	—	—	—
可选宽度 Available Width 塑料缩水率引致的正常误差：正负差距 ±3(mm) The normal error caused by the shrinkage of plastic; ±3(mm)							
单片宽度 (Bulk Pieces Width)		组合宽度 (Assemble Width)					
103mm	117mm	103+117*N					
非标宽度 Nonstandard Width		非标定制前请和本公司联系 PLS Contact Hairise Confirm Width Before Booking					

链轮 Sprocket	护栏 Guide	其余配件 Component
S02	R01-R42	C01-C57

Har400 Series Flush Grid MODULAR BELT

MODULAR BELT 400 Series
P=50.8mm, T=16mm
OPEN AREA:17%



节距 Pitch	网链材质 Material	颜色 Color
50.8mm	PP	白色/White 蓝色/Blue

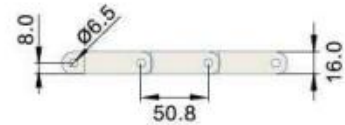
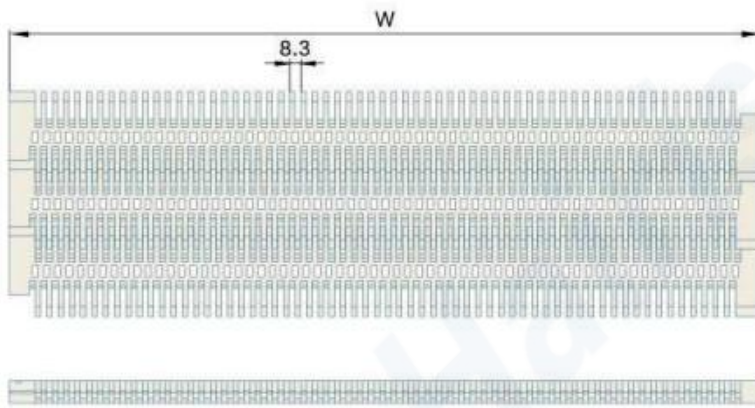

挡板高度 Cleat Height	—	材质 Material	重量 Weight(KG/SQ)	工作负荷 Working Capacity(N/M)
裙边高度 Side Apron Height	—	PP	9.0	35700
穿销材质 Pin Material	PP/NYLON/PBT	—	—	—

可选宽度 Available Width

塑料缩水率引致的正常误差：正负差距 ±3(mm) The normal error caused by the shrinkage of plastic: ±3(mm)

单片宽度 (Bulk Pieces Width)			组合宽度 (Assemble Width)
101mm	151mm	298mm	101+151+298mm*N
非标宽度 Nonstandard Width			非标定制前请和本公司联系 PLS Contact Hairise Confirm Width Before Booking

链轮 Sprocket	护栏 Guide	其余配件 Component
S03-S04	R01-R42	C01-C57

Har400 Series Flush Grid (New Type)

MODULAR BELT

MODULAR BELT 400 Series

P=50.8mm, T=16mm

OPEN AREA:17%



节距 Pitch	网链材质 Material	颜色 Color
50.8mm	PP	白色/White 蓝色/Blue

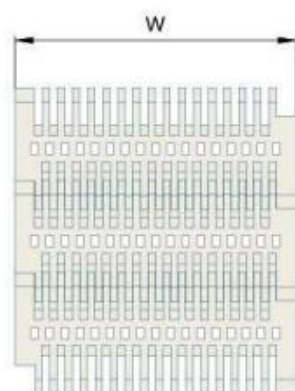

挡板高度 Cleat Height	—	材质 Material	重量 Weight(KG/SQ)	工作负荷 Working Capacity(N/M)
裙边高度 Side Apron Height	—	PP	8.9	36000
穿销材质 Pin Material	PP/NYLON/PBT DIAMETER:6mm	—	—	—
可选宽度 Available Width 塑料缩水率引起的正常误差：正负差距 ±3(mm) The normal error caused by the shrinkage of plastic: ±3(mm)				
单片宽度 (Bulk Pieces Width)		组合宽度 (Assemble Width)		
51mm	301mm	100mm	51+100+50*N	
非标宽度 Nonstandard Width		非标定制前请和本公司联系 PLS Contact Hairise Confirm Width Before Booking		

链轮 Sprocket	护栏 Guide	其余配件 Component
S04	R01-R42	C01-C57

Har400 Series Raised Rib MODULAR BELT

MODULAR BELT 400 Series
P=50.8mm, T=22mm
OPEN AREA:17%



节距 Pitch	网链材质 Material	颜色 Color
50.8mm	PP	灰色/Grey

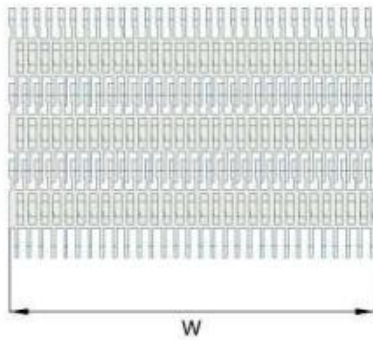

挡板高度 Cleat Height	—	材质 Material	重量 Weight(KG/SQ)	工作负荷 Working Capacity(N/M)
裙边高度 Side Apron Height	—	PP	9.5	36000
穿销材质 Pin Material	PP/NYLON/PBT DIAMETER:6mm	—	—	—
可选宽度 Available Width 塑料缩水率引致的正常误差：正负差距 ±3(mm) The normal error caused by the shrinkage of plastic; ±3(mm)				
单片宽度 (Bulk Pieces Width)			组合宽度 (Assemble Width)	
101mm	151mm	298mm	101+151+50*N	
非标宽度 Nonstandard Width			非标定制前请和本公司联系 PLS Contact Hairise Confirm Width Before Booking	

链轮 Sprocket	护栏 Guide	其余配件 Component
S03-S04	R01-R42	C01-C57

Har400 Series Lateral Pulley Type MODULAR BELT

MODULAR BELT 400 Series

P=50.8mm, T=16mm

OPEN AREA:18%

Roller Direction: 90 degrees Horizontal /
90 degrees Vertical



节距 Pitch	网链材质 Material	颜色 Color
50.8mm	PP	灰底白珠/ Grey Plate White Roller

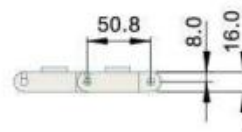
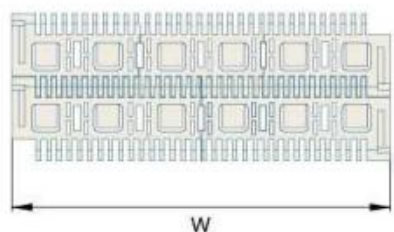

挡板高度 Cleat Height	—	材质 Material	重量 Weight(KG/SQ)	工作负荷 Working Capacity(N/M)
裙边高度 Side Apron Height	—	PP	11.94	36000
穿销材质 Pin Material	PP/NYLON/PBT DIAMETER:6mm	—	—	—
可选宽度 Available Width 塑料缩水率引致的正常误差: 正负差距 ±3(mm) The normal error caused by the shrinkage of plastic; ±3(mm)				
单片宽度 (Bulk Pieces Width)			组合宽度 (Assemble Width)	
102mm	152mm	153mm	102+153+51*N	
非标宽度 Nonstandard Width			非标定制前请和本公司联系 PLS Contact Hairise Confirm Width Before Booking	

链轮 Sprocket	护栏 Guide	其余配件 Component
S03-S04	R01-R42	C01-C57

Har400 Series Ball Belt MODULAR BELT

MODULAR BELT 400 Series
P=50.8mm, T=15.9mm
OPEN AREA:18%



节距 Pitch	网链材质 Material	颜色 Color
50.8mm	PP	灰色/Grey

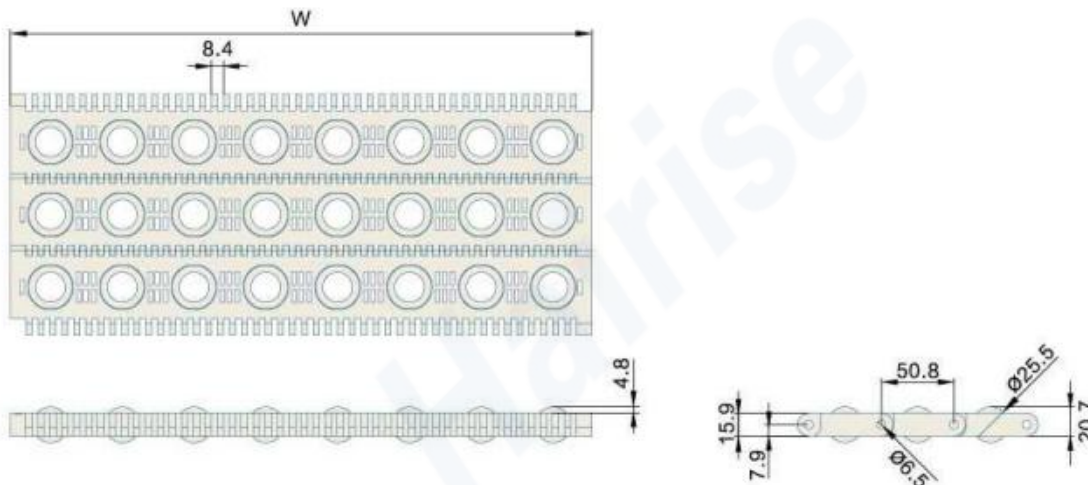

挡板高度 Cleat Height	—	材质 Material	重量 Weight(KG/SQ)	工作负荷 Working Capacity(N/M)
裙边高度 Side Apron Height	—	PP	12.0	32700
穿销材质 Pin Material	PP/NYLON/PBT DIAMETER:6mm	—	—	—
可选宽度 Available Width 塑料缩水率引致的正常误差: 正负差距 ±3(mm) The normal error caused by the shrinkage of plastic: ±3(mm)				
单片宽度 (Bulk Pieces Width)		组合宽度 (Assemble Width)		
104mm	151mm	155mm	104+155+50*N	
非标宽度 Nonstandard Width		非标定制前请和本公司联系 PLS Contact Hairise Confirm Width Before Booking		

链轮 Sprocket	护栏 Guide	其余配件 Component
S04-S05	R01-R42	C01-C57

Har600 Series Fastening MODULAR BELT

MODULAR BELT 600 Series
P=50.8mm, T=16mm
OPEN AREA:0%



节距 Pitch	网链材质 Material	颜色 Color
50.8mm	POM	蓝底红珠/ Blue Plate Red Roller

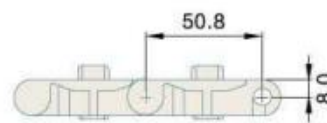
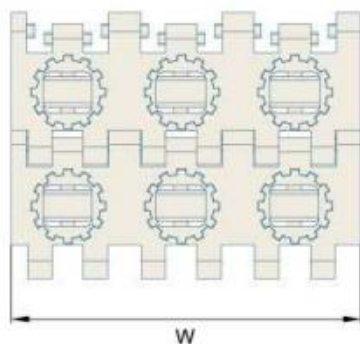

挡板高度 Cleat Height	—	材质 Material	重量 Weight(KG/SQ)	工作负荷 Working Capacity(N/M)
裙边高度 Side Apron Height	—	POM	14.5	27500
穿销材质 Pin Material	—	—	—	—
可选宽度 Available Width 塑料缩水率引致的正常误差: 正负差距 ±3(mm) The normal error caused by the shrinkage of plastic: ±3(mm)				
单片宽度 (Bulk Pieces Width)		组合宽度 (Assemble Width)		
153mm		153+51*N		
非标宽度 Nonstandard Width		非标定制前请和本公司联系 PLS Contact Hairise Confirm Width Before Booking		

链轮 Sprocket	护栏 Guide	其余配件 Component
S07	R01-R42	C01-C57

Har800 Series Flat Top MODULAR BELT

MODULAR BELT 800 Series
P=50.8mm, T=16mm
OPEN AREA:0%

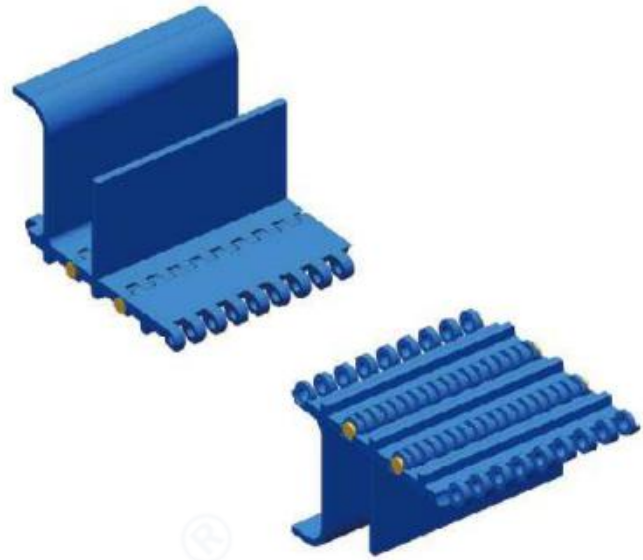

节距 Pitch	网链材质 Material	颜色 Color
50.8mm	PP	蓝色/Blue 白色/White
50.8mm	POM	蓝色/Blue 白色/White

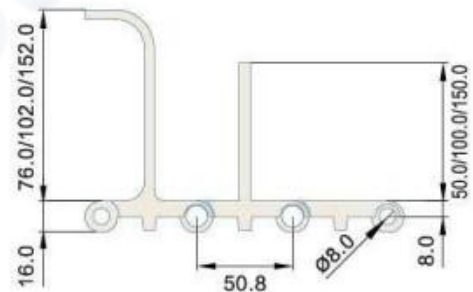
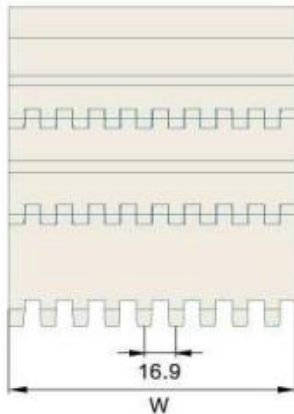

挡板高度 Cleat Height	50/76/100/102/ 152mm	材质 Material	PP	重量 Weight(KG/SQ)	7.96	工作负荷 Working Capacity(N/M)	13400
裙边高度 Side Apron Height	50/76/100mm	PP		7.96		13400	
穿销材质 Pin Material	PP/NYLON/PBT DIAMETER: 7.6mm	POM		14.0		13400	
可选宽度 Available Width 塑料缩水率引致的正常误差: 正负差距 ±3(mm) The normal error caused by the shrinkage of plastic: ±3(mm)							
单片宽度 (Bulk Pieces Width)		组合宽度 (Assemble Width)					
150mm		150mm+17*N					
非标宽度 Nonstandard Width		非标定制前请和本公司联系 PLS Contact Hairise Confirm Width Before Booking					

链轮 Sprocket	护栏 Guide	其余配件 Component
S08	R01-R42	C01-C57

Har800 Series Perforated Flat Top

MODULAR BELT

MODULAR BELT 800 Series

P=50.8mm, T=16mm

OPEN AREA:20%

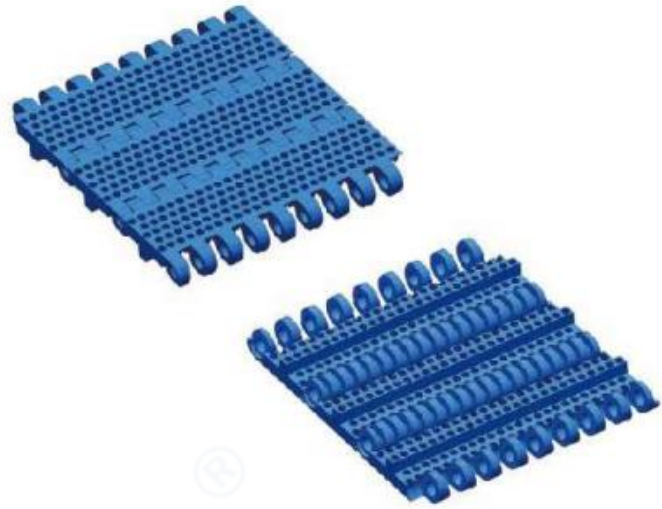

节距 Pitch	网链材质 Material	颜色 Color
50.8mm	PP	蓝色/Blue 白色/White
50.8mm	POM	蓝色/Blue 白色/White

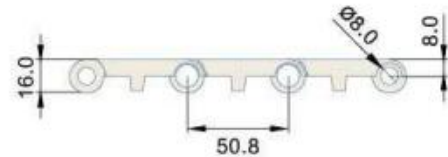
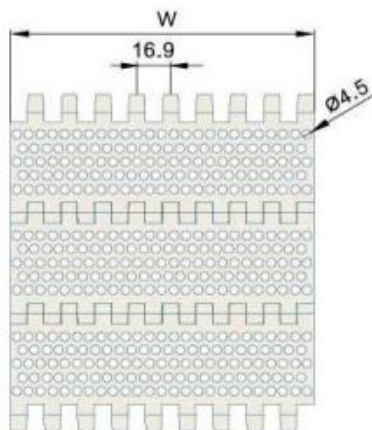

挡板高度 Cleat Height	50/76/100/102/ 152mm	材质 Material	重量 Weight(KG/SQ)	工作负荷 Working Capacity(N/M)
裙边高度 Side Apron Height	50/76/102mm	PP	7.52	13400
穿销材质 Pin Material	PP/NYLON/PBT DIAMETER: 7.6mm	POM	11.15	14900

可选宽度 Available Width

塑料缩水率引致的正常误差: 正负差距 ±3(mm) The normal error caused by the shrinkage of plastic; ±3(mm)

单片宽度 (Bulk Pieces Width)	组合宽度 (Assemble Width)
150mm	150mm+17*N
非标宽度 Nonstandard Width	非标定制前请和本公司联系 PLS Contact Hairise Confirm Width Before Booking

链轮 Sprocket	护栏 Guide	其余配件 Component
S08	R01-R42	C01-C57

Har800 Series Flush Grid MODULAR BELT

MODULAR BELT 800 Series
P=50.8mm, T=16mm
OPEN AREA:18%

节距 Pitch	网链材质 Material	颜色 Color
50.8mm	PP	白色/White 蓝色/Blue
50.8mm	POM	白色/White

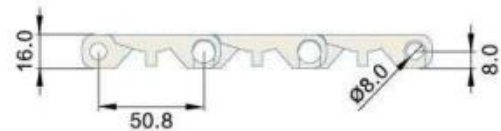
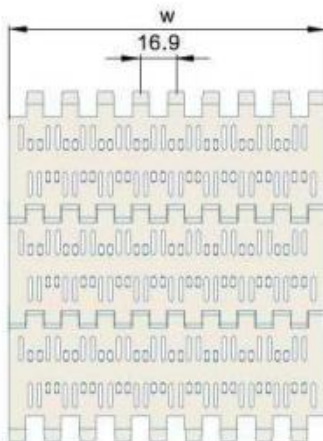
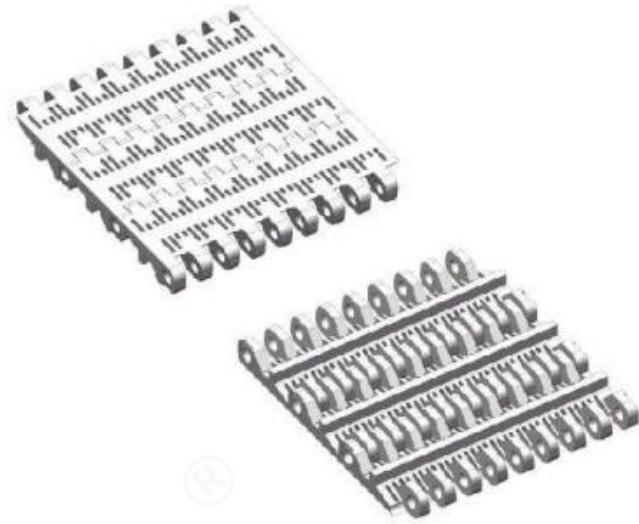

挡板高度 Cleat Height	50/76/100/102/ 152mm	材质 Material	重量 Weight(KG/SQ)	工作负荷 Working Capacity(N/M)
裙边高度 Side Apron Height	50/76/102mm	PP	8.5	13400
穿销材质 Pin Material	PP/NYLON/PBT DIAMETER:7.6mm	POM	13.2	20000

可选宽度 Available Width

塑料缩水率引致的正常误差: 正负差距 ±3(mm) The normal error caused by the shrinkage of plastic: ±3(mm)

单片宽度 (Bulk Pieces Width)	组合宽度 (Assemble Width)
150mm	150+17*N
非标宽度 Nonstandard Width	非标定制前请和本公司联系 PLS Contact Hairise Confirm Width Before Booking

链轮 Sprocket	护栏 Guide	其余配件 Component
S08	R01-R42	C01-C57

Har6100 Series Flat Top MODULAR BELT

MODULAR BELT 6100 Series
P=50.8mm, T=16mm
OPEN AREA:0%

节距 Pitch	网链材质 Material	颜色 Color
50.8mm	PP	白色/White 蓝色/Blue

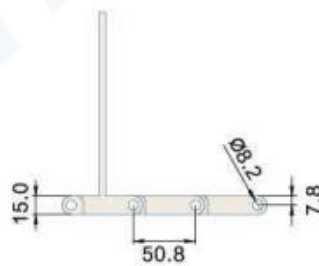
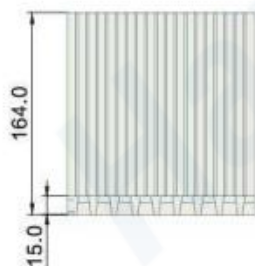
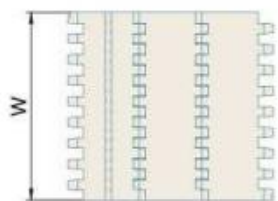
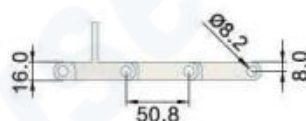
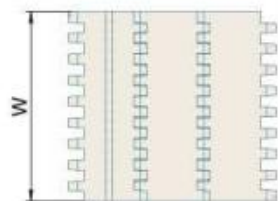
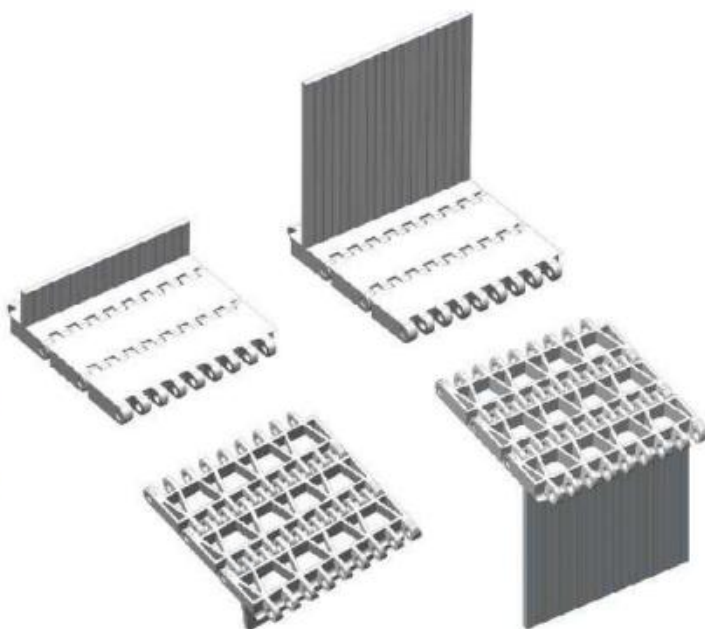

挡板高度 Cleat Height	32/50/75/ 100/150 mm	材质 Material	重量 Weight(KG/SQ)	工作负荷 Working Capacity(N/M)
裙边高度 Side Apron Height	50/76/102 mm	PP	14.0	28700
穿销材质 Pin Material	PP/NYLON/PBT DIAMETER:7.6mm	—	—	—
可选宽度 Available Width 塑料缩水率引致的正常误差: 正负差距 ±3(mm) The normal error caused by the shrinkage of plastic: ±3(mm)				
单片宽度 (Bulk Pieces Width)		组合宽度 (Assemble Width)		
133mm	152mm	—		
非标宽度 Nonstandard Width		非标定制前请和本公司联系 PLS Contact Hairise Confirm Width Before Booking		

链轮 Sprocket	护栏 Guide	其余配件 Component
S53	R01-R42	C01-C57

Har6100 Series Flush Grid MODULAR BELT

MODULAR BELT 6100 Series
P=50.8mm, T=16mm
OPEN AREA:23%



节距 Pitch	网链材质 Material	颜色 Color
50.8mm	PP	白色/White 蓝色/Blue

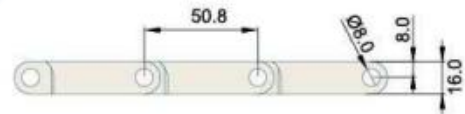
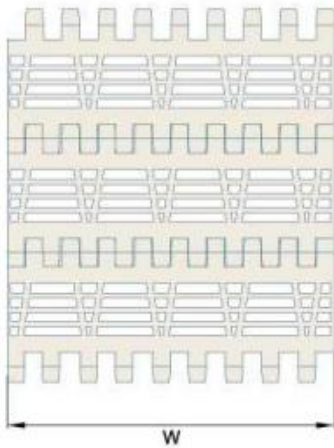

挡板高度 Cleat Height	32/50/75/ 100/150 mm	材质 Material	重量 Weight(KG/SQ)	工作负荷 Working Capacity(N/M)
裙边高度 Side Apron Height	50/76/102 mm	PP	7.0	11000
穿销材质 Pin Material	PP/NYLON/PBT DIAMETER:7.6mm	—	—	—
可选宽度 Available Width 塑料缩水率引致的正常误差: 正负差距 ±3(mm) The normal error caused by the shrinkage of plastic: ±3(mm)				
单片宽度 (Bulk Pieces Width)		组合宽度 (Assemble Width)		
133mm	152mm	—		
非标宽度 Nonstandard Width		非标定制前请和本公司联系 PLS Contact Hairise Confirm Width Before Booking		

链轮 Sprocket	护栏 Guide	其余配件 Component
S53	R01-R42	C01-C57

Har6100 Series Raised Rib MODULAR BELT

MODULAR BELT 6100 Series
P=50.8mm, T=26.0mm
OPEN AREA:23%

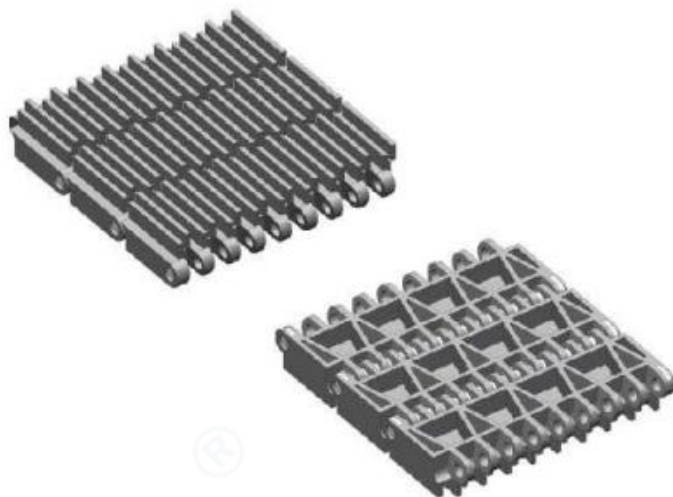

节距 Pitch	网链材质 Material	颜色 Color
50.8mm	PP	棕色/Brown

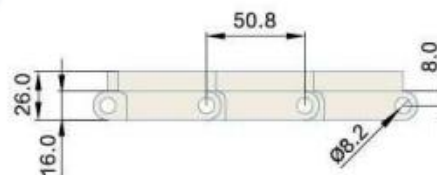
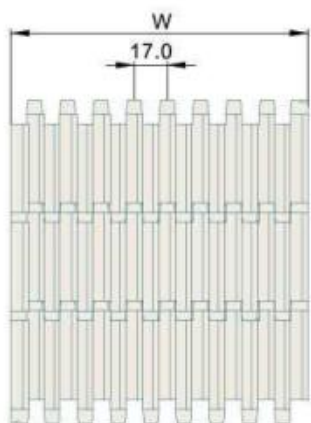

挡板高度 Cleat Height	32/50/75/ 100/150mm	材质 Material	重量 Weight(KG/SQ)	工作负荷 Working Capacity(N/M)
裙边高度 Side Apron Height	50/76/102 mm	PP	9.7	19900
穿销材质 Pin Material	PP/NYLON/PBT DIAMETER:7.6mm	—	—	—

可选宽度 Available Width

塑料缩水率引致的正常误差: 正负差距 ±3(mm) The normal error caused by the shrinkage of plastic: ±3(mm)

单片宽度 (Bulk Pieces Width)	组合宽度 (Assemble Width)
133mm	152mm
非标宽度 Nonstandard Width	非标定制前请和本公司联系 PLS Contact Hairise Confirm Width Before Booking

链轮 Sprocket	护栏 Guide	其余配件 Component
S53	R01-R42	C01-C57

Har6100 Series Perforated Flat Top

MODULAR BELT

MODULAR BELT 6100 Series

P=50.8mm, T=16mm

OPEN AREA:18%



节距 Pitch	网链材质 Material	颜色 Color
50.8mm	PP	白色/White 蓝色/Blue

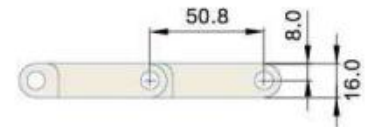
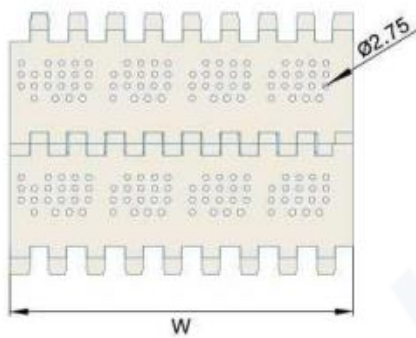

挡板高度 Cleat Height	32/50/75/ 100/150 mm	材质 Material	重量 Weight(KG/SQ)	工作负荷 Working Capacity(N/M)
裙边高度 Side Apron Height	50/76/102 mm	PP	7.2	11000
穿销材质 Pin Material	PP/NYLON/PBT DIAMETER:7.6mm	—	—	—
可选宽度 Available Width 塑料缩水率引致的正常误差: 正负差距 ± 3 (mm) The normal error caused by the shrinkage of plastic: ± 3 (mm)				
单片宽度 (Bulk Pieces Width)		组合宽度 (Assemble Width)		
152mm	133mm	—		
非标宽度 Nonstandard Width		非标定制前请和本公司联系 PLS Contact Hairise Confirm Width Before Booking		

链轮 Sprocket	护栏 Guide	其余配件 Component
S53	R01-R42	C01-C57

Har7200 Series Flush Grid MODULAR BELT

MODULAR BELT 7200 Series
P=50.8mm, T=17.3mm
OPEN AREA:38%



节距 Pitch	网链材质 Material	颜色 Color
50.8mm	PP	白色/White
50.8mm	PP	灰色/Grey

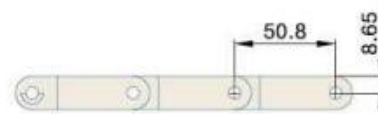
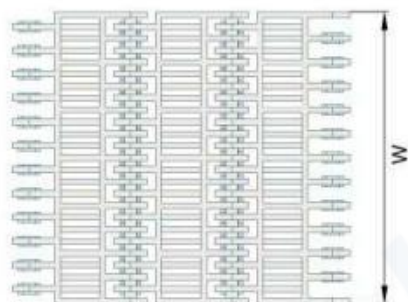

挡板高度 Cleat Height	—	材质 Material	重量 Weight(KG/SQ)	工作负荷 Working Capacity(N/M)
裙边高度 Side Apron Height	—	PP	10.4	26000
穿销材质 Pin Material	PP/NYLON/PBT DIAMETER:4.6mm	—	—	—
可选宽度 Available Width 塑料缩水率引致的正常误差: 正负差距 ±3(mm) The normal error caused by the shrinkage of plastic: ±3(mm)				
单片宽度 (Bulk Pieces Width)		组合宽度 (Assemble Width)		
150mm		150*N		
非标宽度 Nonstandard Width		非标定制前请和本公司联系 PLS Contact Hairise Confirm Width Before Booking		

链轮 Sprocket	护栏 Guide	其余配件 Component
—	R01-R42	C01-C57

Har3110 Series Raised Rib MODULAR BELT

MODULAR BELT 3110 Series
P=50.8mm, T=23.9mm
OPEN AREA:26%

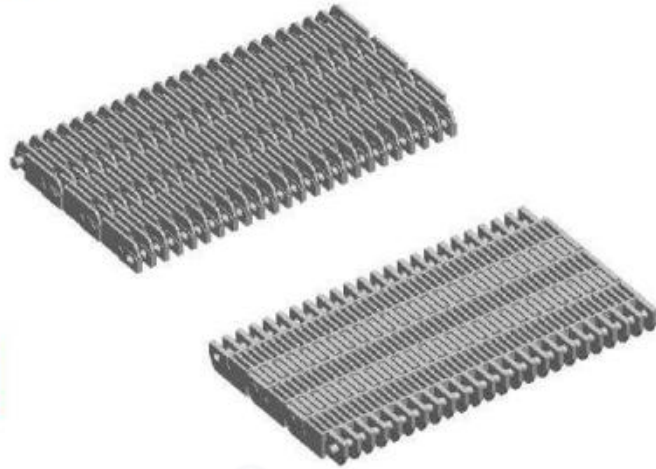

节距 Pitch	网链材质 Material	颜色 Color
50.8mm	PP	棕色/Brown

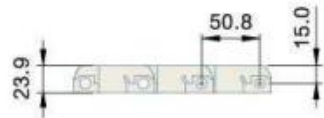
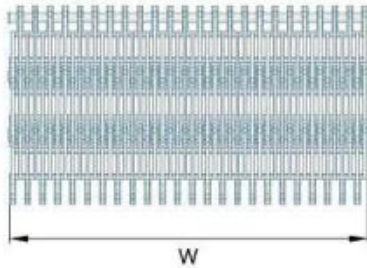

挡板高度 Cleat Height	—	材质 Material	重量 Weight(KG/SQ)	工作负荷 Working Capacity(N/M)
裙边高度 Side Apron Height	—	PP	11.7	28000
穿销材质 Pin Material	PP/NYLON/PBT DIAMETER:7.2mm	—	—	—
可选宽度 Available Width 塑料缩水率引致的正常误差: 正负差距 ±3(mm) The normal error caused by the shrinkage of plastic; ±3(mm)				
单片宽度 (Bulk Pieces Width)			组合宽度 (Assemble Width)	
114.7mm	303.5mm	190.3mm	305*76.2*N	
非标宽度 Nonstandard Width			非标定制前请和本公司联系 PLS Contact Hairise Confirm Width Before Booking	

链轮 Sprocket	护栏 Guide	其余配件 Component
S50	R01-R42	C01-C57

Har8200 Series Curve MODULAR BELT

MODULAR BELT 8200 Series
P=50.8mm, T=14.5mm
OPEN AREA:62%



节距 Pitch	网链材质 Material	颜色 Color	转弯系数 Turn Radius
50.8mm	POM	白色/White	2.5
50.8mm	POM	蓝色/Blue	2.5

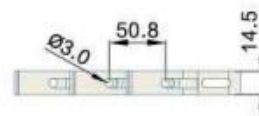
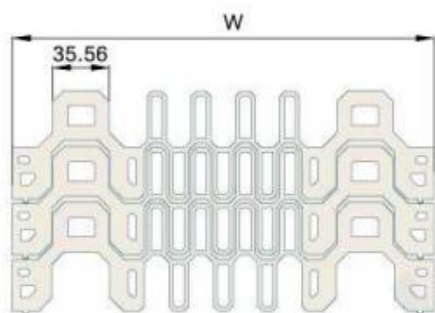

挡板高度 Cleat Height	—	材质 Material	重量 Weight(KG/SQ)	工作负荷 Working Capacity(N/M)
裙边高度 Side Apron Height	—	POM	11.0	6800
穿销材质 Pin Material	PP/NYLON/PBT DIAMETER:6mm	—	—	—
可选宽度 Available Width 塑料缩水率引致的正常误差: 正负差距 ±3(mm) The normal error caused by the shrinkage of plastic: ±3(mm)				
单片宽度 (Bulk Pieces Width)			组合宽度 (Assemble Width)	
80mm	201mm	170mm	250+201*N	
非标宽度 Nonstandard Width			非标定制前请和本公司联系 PLS Contact Hairise Confirm Width Before Booking	

链轮 Sprocket	护栏 Guide	其余配件 Component
S62	R01-R42	C01-C57

Har7950 Series Flush Grid MODULAR BELT

MODULAR BELT 7950 Series
P=50.8mm, T=9.6mm
OPEN AREA:45%

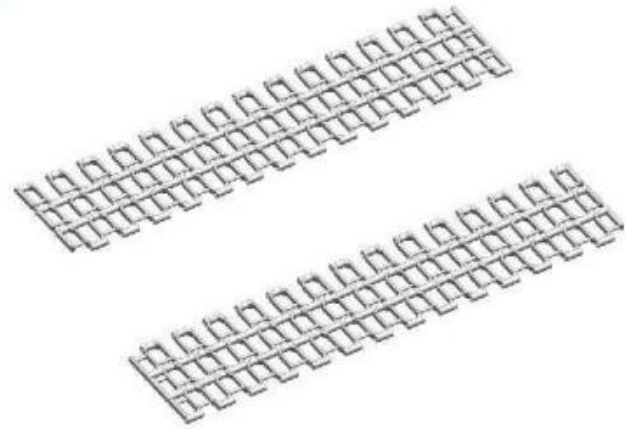

节距 Pitch	网链材质 Material	颜色 Color
50.8mm	POM	蓝色/Blue

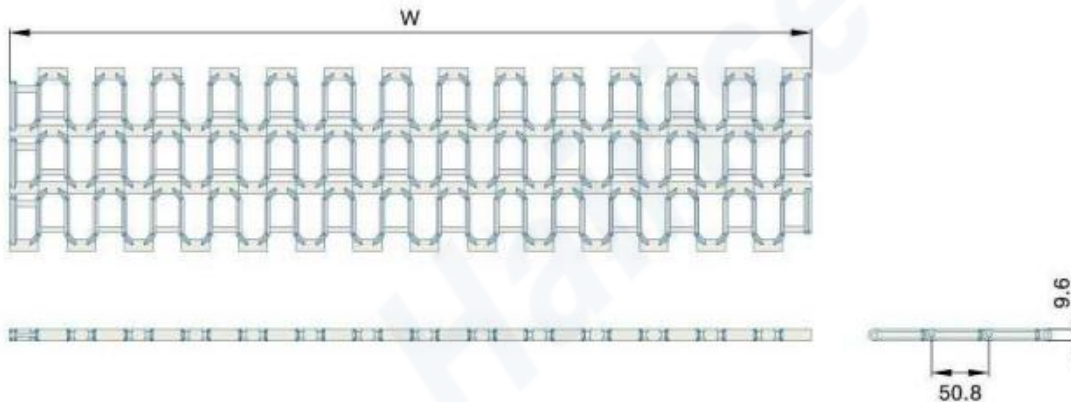

挡板高度 Cleat Height	—	材质 Material	POM	重量 Weight(KG/SQ)	10.0	工作负荷 Working Capacity(N/M)	29700
裙边高度 Side Apron Height	—						
穿销材质 Pin Material	PP/NYLON/PBT DIAMETER:6mm	—	—	—	—	—	—
可选宽度 Available Width 塑料缩水率引致的正常误差：正负差距 ±3(mm) The normal error caused by the shrinkage of plastic; ±3(mm)							
单片宽度 (Bulk Pieces Width)		组合宽度 (Assemble Width)					
700mm		700+51*N					
非标宽度 Nonstandard Width		非标定制前请和本公司联系 PLS Contact Hairise Confirm Width Before Booking					

链轮 Sprocket	护栏 Guide	其余配件 Component
S61	R01-R42	C01-C57

Har5997 Series Raised Rib MODULAR BELT

MODULAR BELT 5997 Series
P=57.2mm, T=24.6mm
OPEN AREA:21%

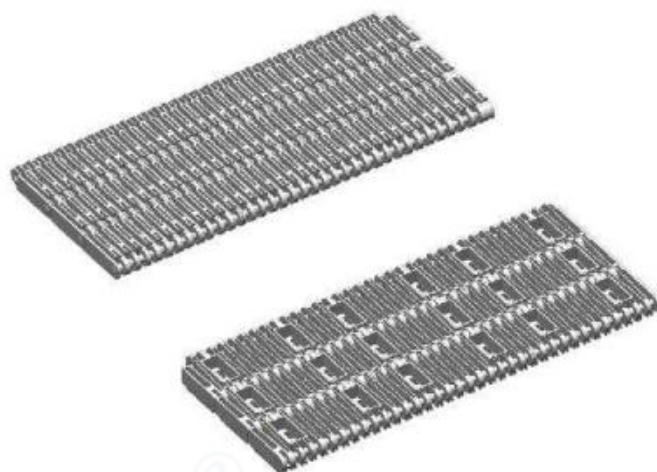

节距 Pitch	网链材质 Material	颜色 Color
57.2mm	PP	棕色/Brown

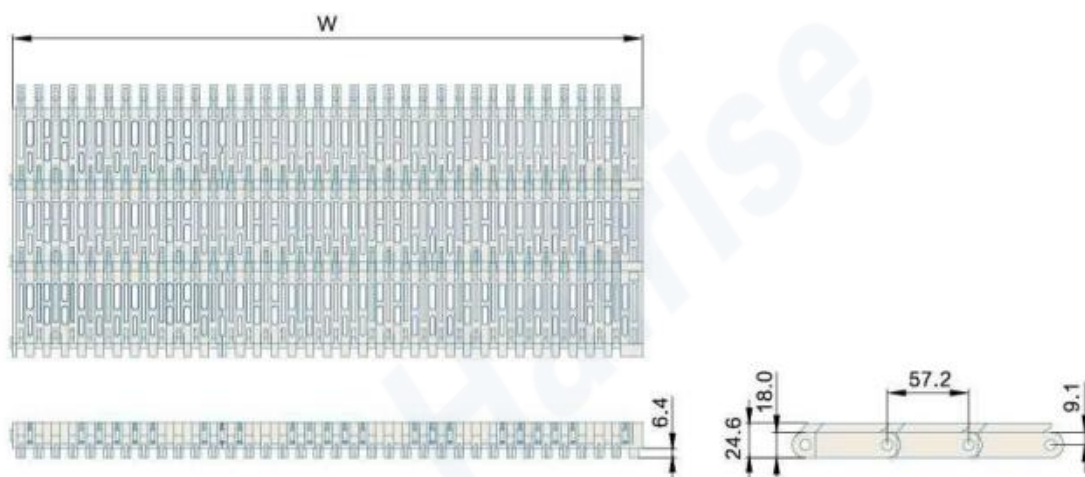

挡板高度 Cleat Height	—	材质 Material	重量 Weight(KG/SQ)	工作负荷 Working Capacity(N/M)
裙边高度 Side Apron Height	—	PP	11.3	—
穿销材质 Pin Material	PP/NYLON/PBT DIAMETER:6mm	—	—	—
可选宽度 Available Width 塑料缩水率引致的正常误差：正负差距 ±3(mm) The normal error caused by the shrinkage of plastic; ±3(mm)				
单片宽度 (Bulk Pieces Width)		组合宽度 (Assemble Width)		
152.4mm	304.8mm	304.8+76*N		
非标宽度 Nonstandard Width		非标定制前请和本公司联系 PLS Contact Hairise Confirm Width Before Booking		

链轮 Sprocket	护栏 Guide	其余配件 Component
S52	R01-R42	C01-C57

Har4809 Series Raised Rib MODULAR BELT

MODULAR BELT 4809 Series
P=57.15mm, T=23.8mm
OPEN AREA:34%

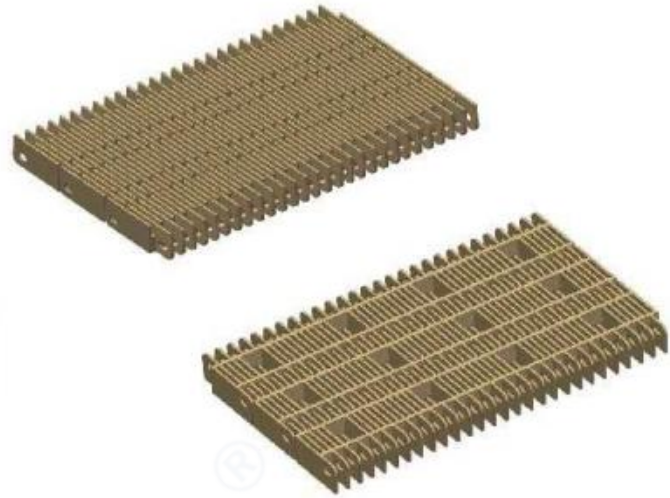

节距 Pitch	网链材质 Material	颜色 Color
57.15mm	PP	咖啡色/Brown

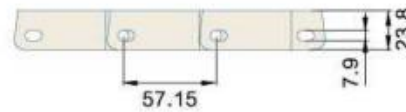
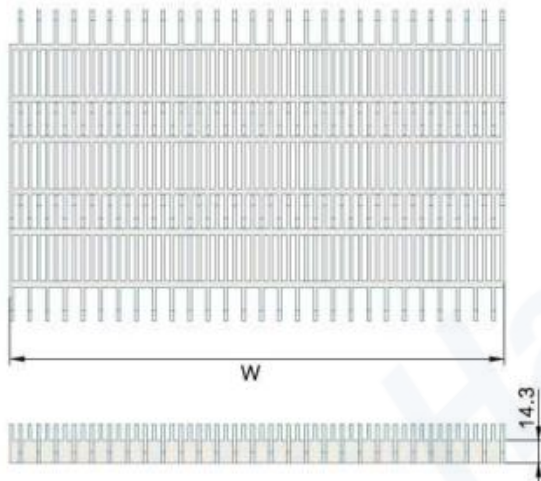

挡板高度 Cleat Height	—	材质 Material	重量 Weight(KG/SQ)	工作负荷 Working Capacity(N/M)
裙边高度 Side Apron Height	—	PP	10.0	29200
穿销材质 Pin Material	PP/NYLON/PBT DIAMETER:6mm	—	—	—
可选宽度 Available Width 塑料缩水率引致的正常误差：正负差距 ±3(mm) The normal error caused by the shrinkage of plastic; ±3(mm)				
单片宽度 (Bulk Pieces Width)		组合宽度 (Assemble Width)		
152.4mm		152.4*N		
非标宽度 Nonstandard Width		非标定制前请和本公司联系 PLS Contact Hairise Confirm Width Before Booking		

链轮 Sprocket	护栏 Guide	其余配件 Component
S51	R01-R42	C01-C57

Har7620 Series Flat Top MODULAR BELT

MODULAR BELT 7620 Series
P=76.2mm, T=32mm
OPEN AREA:0%



节距 Pitch	网链材质 Material	颜色 Color
76.2mm	POM	黑色/Black

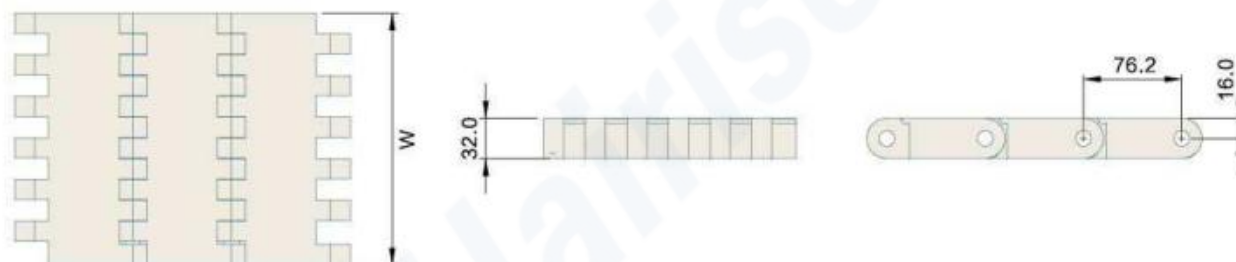

挡板高度 Cleat Height	54mm	材质 Material	POM	重量 Weight(KG/SQ)	52	工作负荷 Working Capacity(N/M)	100000
裙边高度 Side Apron Height	—						
穿销材质 Pin Material	SS DIAMETER:11mm	—	—	—	—	—	—
可选宽度 Available Width 塑料缩水率引致的正常误差: 正负差距 ±3(mm) The normal error caused by the shrinkage of plastic: ±3(mm)							
单片宽度 (Bulk Pieces Width)		组合宽度 (Assemble Width)					
100mm	200mm	200+100*N					
非标宽度 Nonstandard Width		非标定制前请和本公司联系 PLS Contact Hairise Confirm Width Before Booking					

链轮 Sprocket	护栏 Guide	其余配件 Component
—	R01-R42	C01-C57

Har7620 Series Cleat MODULAR BELT

MODULAR BELT 7620 Series
P=76.2mm, T=86mm
OPEN AREA:0%

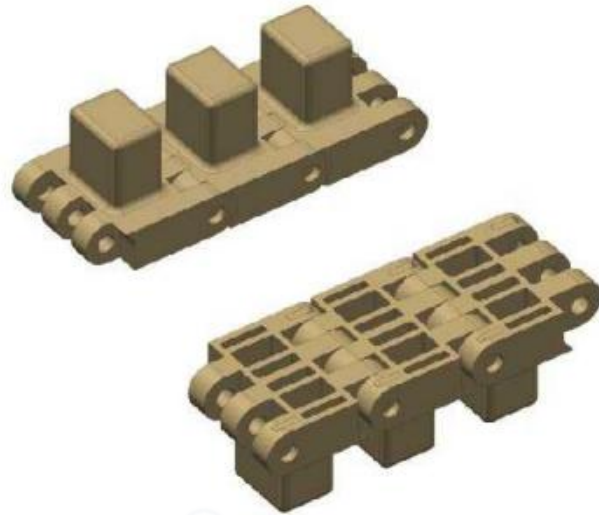

节距 Pitch	网链材质 Material	颜色 Color
76.2mm	POM	黄色/Yellow

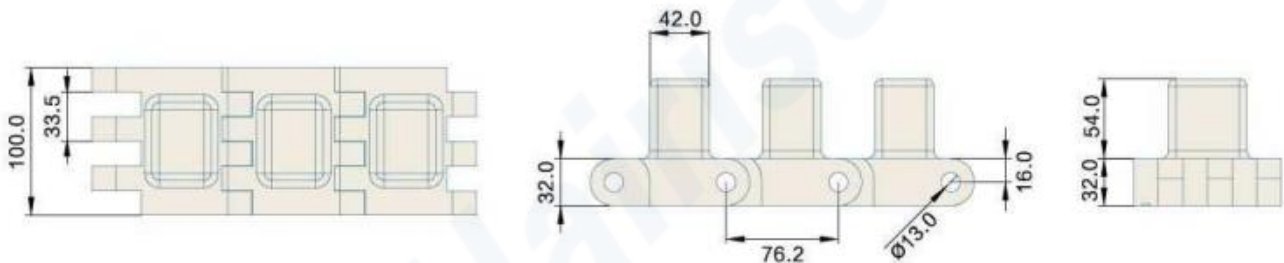

挡板高度 Cleat Height	54mm	材质 Material	POM	重量 Weight(KG/SQ)	—	工作负荷 Working Capacity(N/M)	—
裙边高度 Side Apron Height	—	穿销材质 Pin Material	SS DIAMETER:11mm	—	—	—	—
可选宽度 Available Width 塑料缩水率引致的正常误差: 正负差距 ±3(mm) The normal error caused by the shrinkage of plastic; ±3(mm)							
单片宽度 (Bulk Pieces Width)		组合宽度 (Assemble Width)					
100mm		100*N					
非标宽度 Nonstandard Width		非标定制前请和本公司联系 PLS Contact Hairise Confirm Width Before Booking					

链轮 Sprocket	护栏 Guide	其余配件 Component
—	R01-R42	C01-C57

Har8600 Series Curve MODULAR BELT

MODULAR BELT 8600 Series
T=10mm OPEN AREA:0%
Curve Degree: 90/180

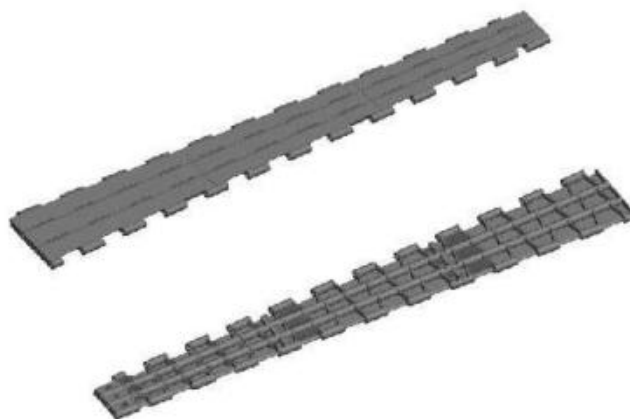

节距 Pitch	网链材质 Material	颜色 Color
—	POM	灰色/Grey

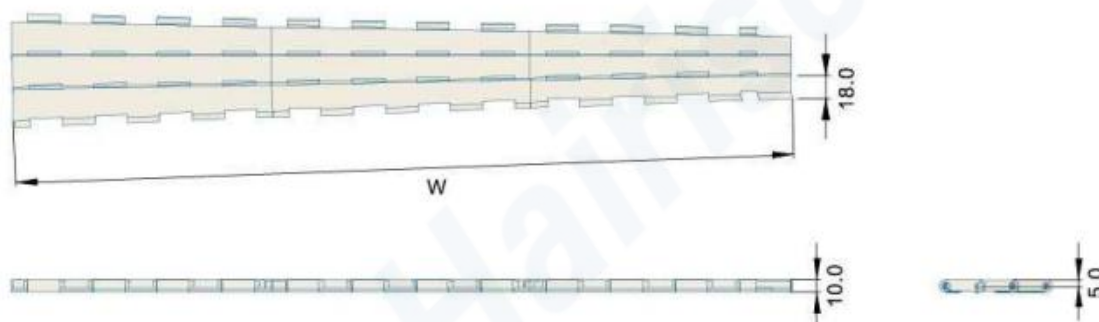

挡板高度 Cleat Height	—	材质 Material	重量 Weight(KG/SQ)	工作负荷 Working Capacity(N/M)	
裙边高度 Side Apron Height	—	POM	26.0	—	
穿销材质 Pin Material	PP/NYLON/PBT	—	—	—	
可选宽度 Available Width 塑料缩水率引致的正常误差: 正负差距 ±3(mm) The normal error caused by the shrinkage of plastic: ±3(mm)					
单片宽度 (Bulk Pieces Width)		组合宽度 (Assemble Width)			
—		600mm	800mm	1000mm	1200mm
非标宽度 Nonstandard Width		非标定制前请和本公司联系 PLS Contact Hairise Confirm Width Before Booking			

链轮 Sprocket	护栏 Guide	其余配件 Component
S63-S65	R01-R42	C01-C57

Har1272 Series Flat Top Curve

MODULAR BELT

MODULAR BELT 1272 Series
 P=12.7mm, T=8.7mm
 OPEN AREA:0%

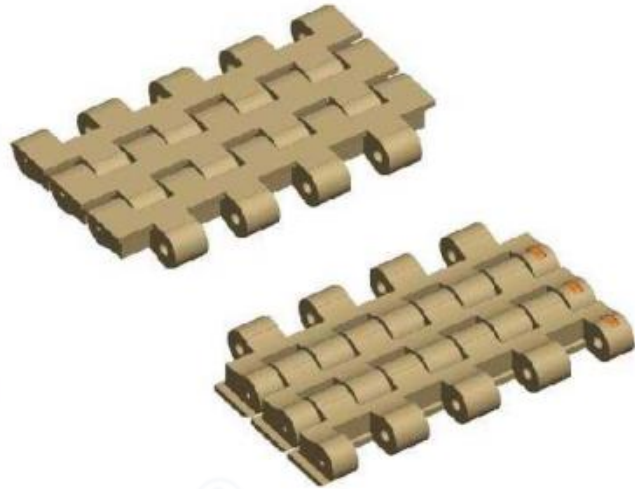

节距 Pitch	网链材质 Material	颜色 Color	转弯半径 Curve Radius
25.4mm	POM	浅湖蓝/ Blue	450mm

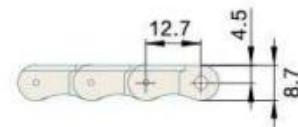
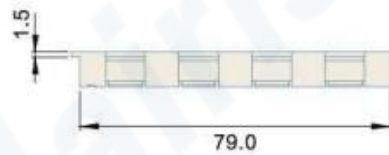
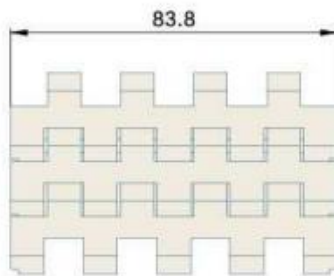

挡板高度 Cleat Height	—	材质 Material	重量 Weight(KG/SQ)	工作负荷 Working Capacity(N/M)
裙边高度 Side Apron Height	—	POM	1.11	2500
穿销材质 Pin Material	SUS304:4mm	—	—	—

可选宽度 Available Width

塑料缩水率引致的正常误差: 正负差距 ±3(mm) The normal error caused by the shrinkage of plastic: ±3(mm)

单片宽度 (Bulk Pieces Width)	组合宽度 (Assemble Width)
83.8mm	83.8mm
非标宽度 Nonstandard Width	非标定制前请和本公司联系 PLS Contact Hairise Confirm Width Before Booking

链轮 Sprocket	护栏 Guide	其余配件 Component
—	R01-R42	C01-C57

Hairise 机加工链轮键槽标准: 圆孔Round Bore 20-6mm, 25-8mm, 30/35-8/10mm, 40-12mm

Sprocket For Har100 Modular Belt

Har100型网链机加工链轮

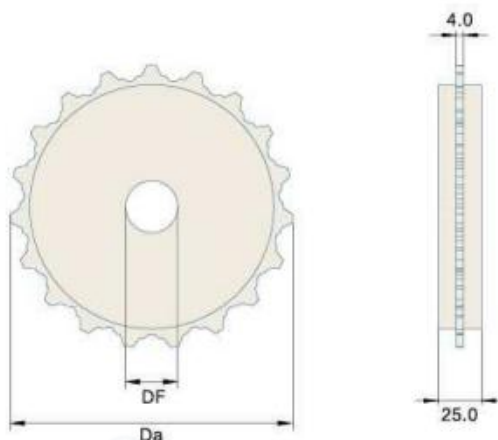

型号 Item Code	齿数 Teeth No.	外径 Da (mm)	方孔 Square Bore (mm)	圆孔 Round Bore (mm)
机加工链轮 Machined Sprocket				
Har100-19T	19	162.5	30/40	30/40

Sprocket For Har100 Modular Belt

Har100型注塑链轮

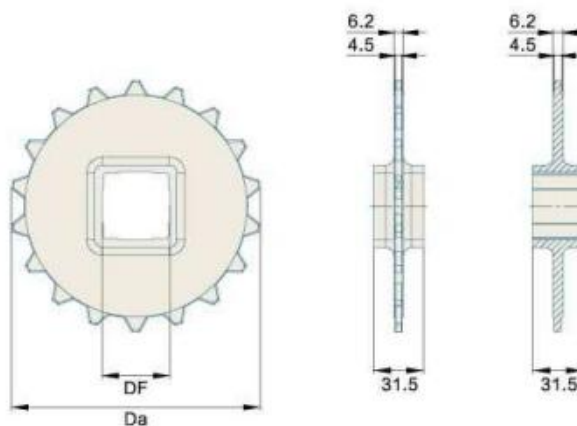
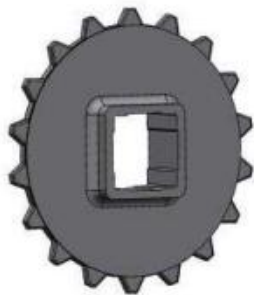

型号 Item Code	齿数 Teeth No.	外径 Da (mm)	方孔 Square Bore (mm)	圆孔 Round Bore (mm)
注塑链轮 Injection Sprocket				
Har100-19T	19	158.5	40	30

Sprocket For Har200 Modular Belt

Har200型网链注塑链轮

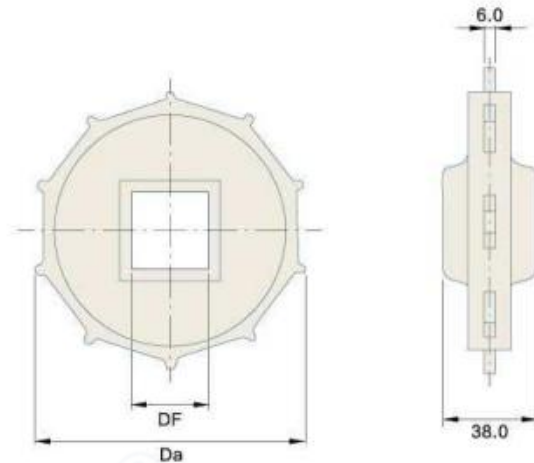

型号 Item Code	齿数 Teeth No.	外径 Da (mm)	方孔 Square Bore (mm)	圆孔 Round Bore (mm)
注塑链轮 Injection Sprocket				
Har200-10T	10	158.5	40	30

Sprocket For Har200 Modular Belt

Har200型网链机加工链轮

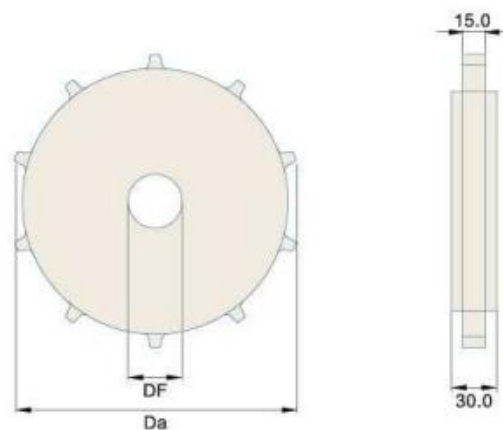

型号 Item Code	齿数 Teeth No.	外径 Da (mm)	方孔 Square Bore (mm)	圆孔 Round Bore (mm)
机加工链轮 Machined Sprocket				
Har200-10T	10	162	25/30/40	25/30/40

Sprocket For Har400 Modular Belt

Har400型平格网链机加工链轮

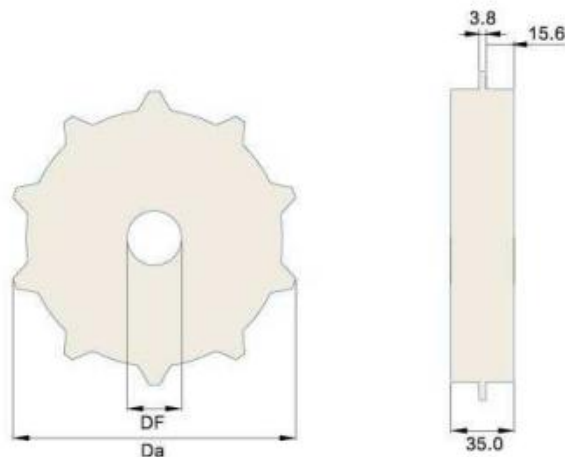

型号 Item Code	齿数 Teeth No.	外径 Da (mm)	方孔 Square Bore (mm)	圆孔 Round Bore (mm)
机加工链轮 Machined Sprocket				
Har400-6T	6	98	40	25/30
Har400-8T	8	130	40	25/30
Har400-10T	10	162.5	40	30
Har400-12T	12	198	40/50/60	30/35/40
Har400-16T	16	259	80/90	50/60

备注：适用于400平格网链（细齿），400滚珠网链。

Sprocket For Har400 Flush Grid Modular Belt

Har400型平格网链注塑链轮 6齿

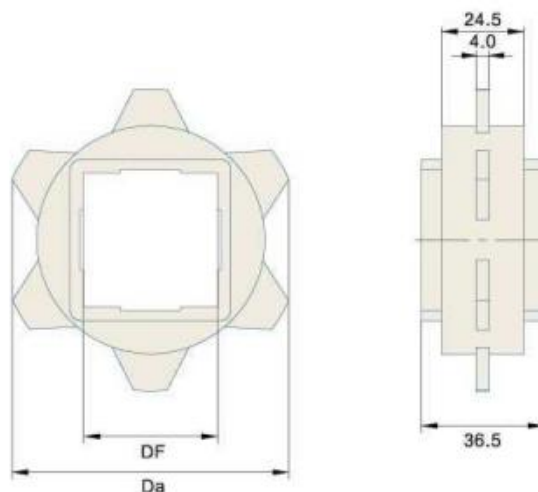

型号 Item Code	齿数 Teeth No.	外径 Da (mm)	方孔 Square Bore (mm)	圆孔 Round Bore (mm)
注塑链轮 Injection Sprocket				
Har400-6T	6	102	40	25/30

Sprocket For Har400 Modular Belt

Har400型平格网链注塑链轮 16齿

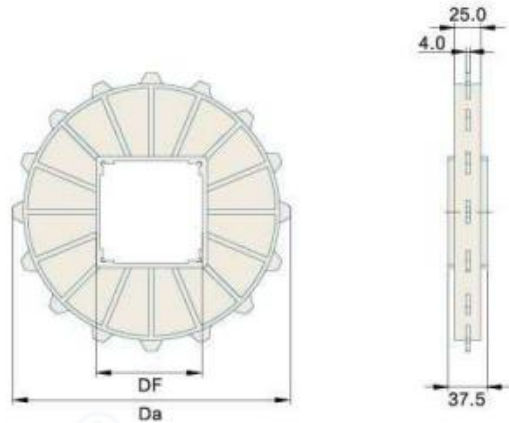
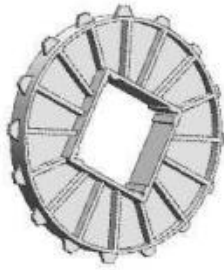

型号 Item Code	齿数 Teeth No.	外径 Da (mm)	方孔 Square Bore (mm)	圆孔 Round Bore (mm)
注塑链轮 Injection Sprocket				
Har400-16T	16	259	90	—

Sprocket For Har400 FG New Type Modular Belt

Har400型新款网链机加工链轮

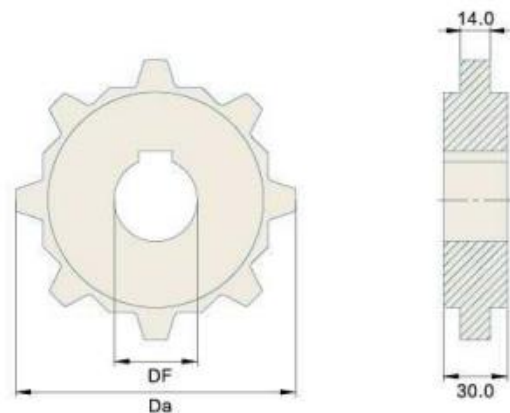

型号 Item Code	齿数 Teeth No.	外径 Da (mm)	方孔 Square Bore (mm)	圆孔 Round Bore (mm)
机加工链轮 Machined Sprocket				
Har400-8T	8	130	30-50	30-50
Har400-10T	10	162.5	40-70	40-70
Har400-12T	12	198	40-70	40-70
Har400-16T	16	259	40-90	40-90

备注：适用于400平格网链（粗齿），400万向滚珠网链。

Sprocket For Har400RB Modular Belt

Har400RB型注塑链轮 8齿

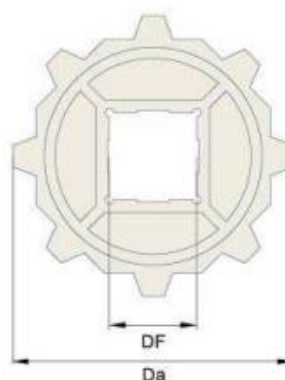

型号 Item Code	齿数 Teeth No.	外径 Da (mm)	方孔 Square Bore (mm)	圆孔 Round Bore (mm)
注塑链轮 Injection Sprocket				
Har400RB-8T	8	129	40	—

Sprocket For Har500 Flush Grid Modular Belt

Har500型网链机加工链轮

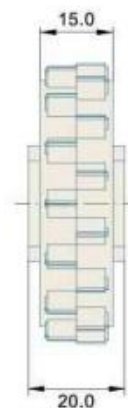
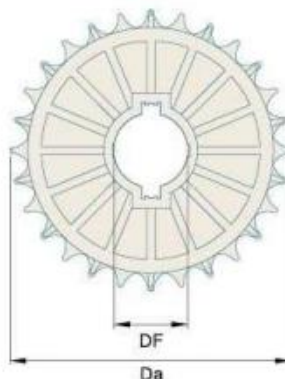

型号 Item Code	齿数 Teeth No.	外径 Da (mm)	方孔 Square Bore (mm)	圆孔 Round Bore (mm)
机加工链轮 Machined Sprocket				
Har500-28T	28	113.4	40	30/40
Har500-38T	38	153.8	40	30/40

Sprocket For Har50SG Modular Belt

Har50SG型网链机加工链轮

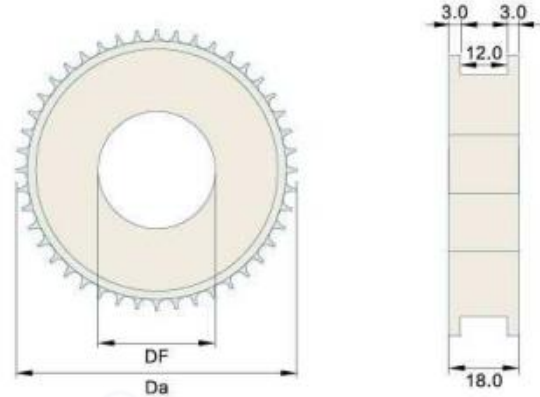

型号 Item Code	齿数 Teeth No.	外径 Da (mm)	方孔 Square Bore (mm)	圆孔 Round Bore (mm)
机加工链轮 Machined Sprocket				
Har50SG-44T	44	72	—	25/30/35

Sprocket For Har515 Top Chains

Har515型链板机加工链轮

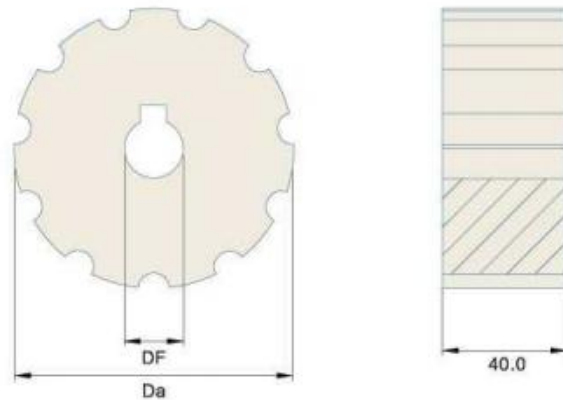

型号 Item Code	齿数 Teeth No.	外径 Da (mm)	方孔 Square Bore (mm)	圆孔 Round Bore (mm)
机加工链轮 Machined Sprocket				
Har515-11T	11	90	25	10
Har515-13T	13	107	25	25
Har515-14T	14	115	20/30/40	20/30/40
Har515-15T	15	123	20/30/40	20/30/40
Har515-16T	16	131	30	30
Har515-19T	19	155	40	40

Sprocket For Har600 Multiflex Chains

Har600型柔性链机加工链轮

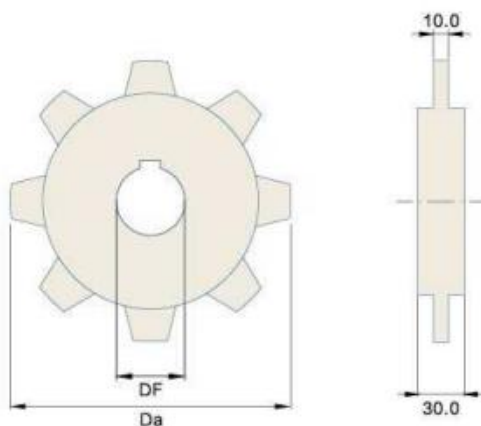

型号 Item Code	齿数 Teeth No.	外径 Da (mm)	方孔 Square Bore (mm)	圆孔 Round Bore (mm)
机加工链轮 Machined Sprocket				
Har600-8T	8	172	20/30/40	20/30/40
Har600-10T	10	214	20/30/40	20/30/40
Har600-11T	11	230	20/30/40	20/30/40
Har600-12T	12	255	20/30/40	20/30/40
Har600-14T	14	296.5	20/30/40	20/30/40

Sprocket For Har600 Roller Modular Belt

Har600型网链机加工链轮

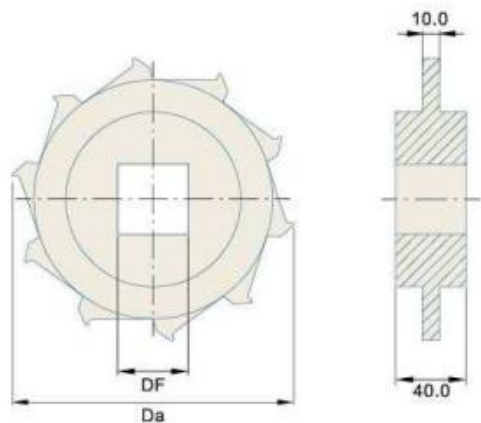

型号 Item Code	齿数 Teeth No.	外径 Da (mm)	方孔 Square Bore (mm)	圆孔 Round Bore (mm)
机加工链轮 Machined Sprocket				
Har600-6T	6	101.6	30/40	30/40
Har600-8T	8	132.8	30/40	30/40
Har600-10T	10	164.4	30/40	30/40
Har600-12T	12	195.0	30/40/50	30/40/50
Har600-16T	16	260.4	30/40/50/60	30/40/50/60

Sprocket For Har800 Modular Belt

Har800型网链机加工链轮

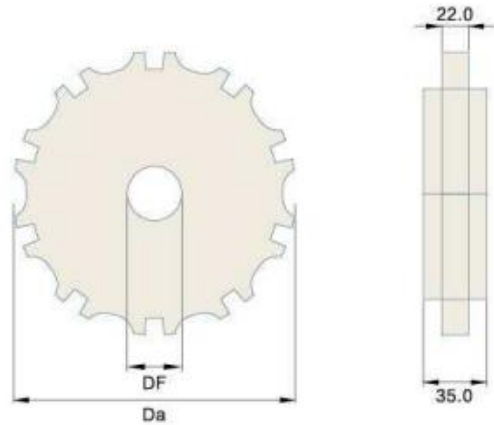

型号 Item Code	齿数 Teeth No.	外径 Da (mm)	方孔 Square Bore (mm)	圆孔 Round Bore (mm)
机加工链轮 Machined Sprocket				
Har800-8T	8	127	30/40	30/40
Har800-9T	9	141.5	30/40	30/40
Har800-10T	10	157	30/40	30/40

Sprocket For Har800 Modular Belt

Har800型注塑链轮

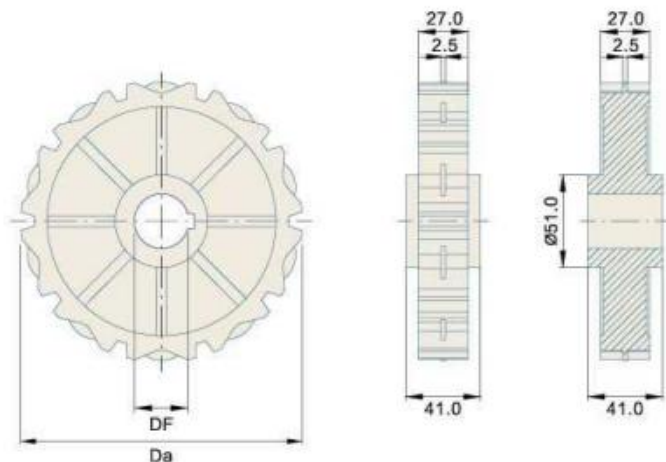
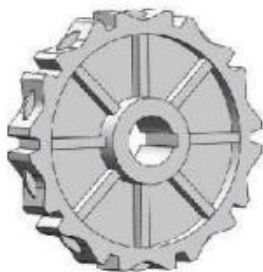

型号 Item Code	齿数 Teeth No.	外径 Da (mm)	方孔 Square Bore (mm)	圆孔 Round Bore (mm)
注塑链轮 Injection Sprocket				
Har800-10T	10	164	40	40

Sprocket For Har 1775 Flexible Chains

Har1775型柔性链机加工链轮

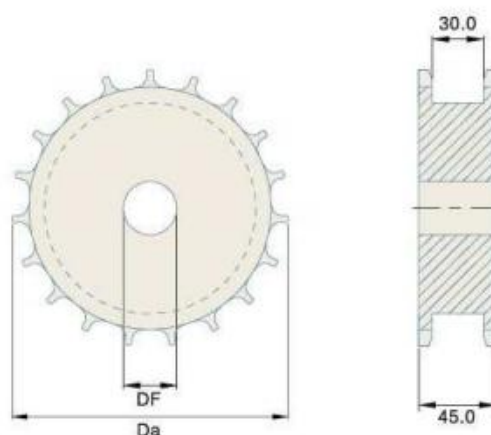

型号 Item Code	齿数 Teeth No.	外径 Da (mm)	方孔 Square Bore (mm)	圆孔 Round Bore (mm)
机加工链轮 Machined Sprocket				
Har1775-13T	13	108	—	20/30/40
Har1775-17T	17	141	—	20/30/40
Har1775-21T	21	173	—	20/30/40
Har1775-25T	25	206	—	20/30/40

Idler Sprocket For Har812 Top Chains

Har812型被动机加工链轮

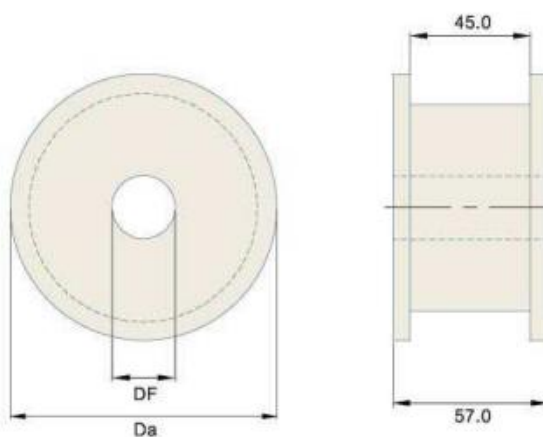

型号 Item Code	齿数 Teeth No.	外径 Da (mm)	方孔 Square Bore (mm)	圆孔 Round Bore (mm)
机加工链轮 Machined Sprocket				
Har812-19T	19	117	25/30/35	25/30/35
Har812-21T	21	129	25/30/35/40	25/30/35/40
Har812-23T	23	143	25/30/35/40	25/30/35/40
Har812-25T	25	155	25/30/35/40	25/30/35/40

Sprocket For Har812 Top Chains

Har812型链板注塑链轮

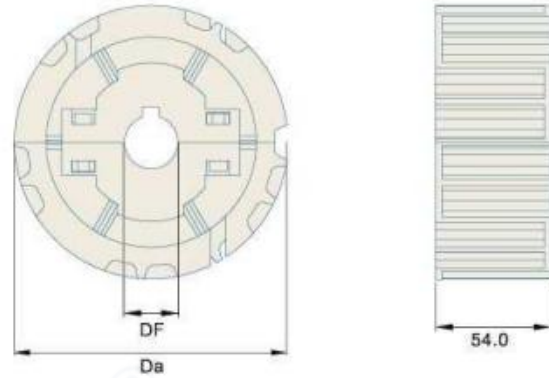
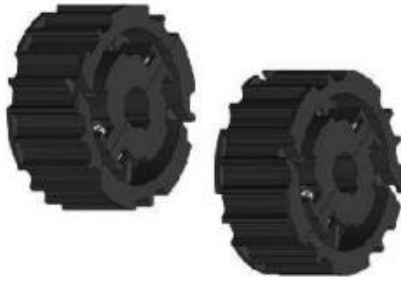

型号 Item Code	齿数 Teeth No.	外径 Da (mm)	方孔 Square Bore (mm)	圆孔 Round Bore (mm)
注塑链轮 Injection Sprocket				
Har812-19T	19	117	—	25/30/35
Har812-21T	21	129	—	25/30/35/40

Sprocket For Har812 Top Chains

Har812型链板注塑链轮 23齿

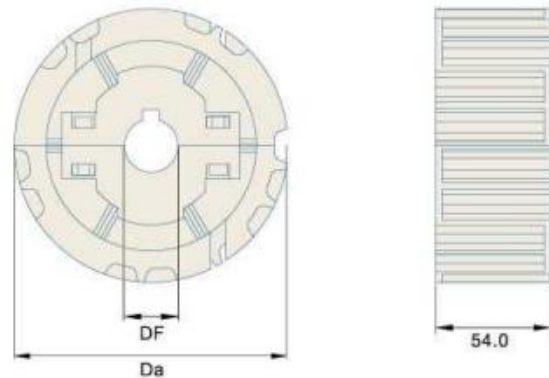
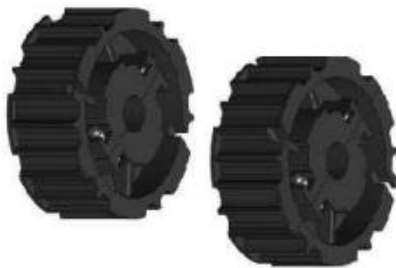

型号 Item Code	齿数 Teeth No.	外径 Da (mm)	方孔 Square Bore (mm)	圆孔 Round Bore (mm)
注塑链轮 Injection Sprocket				
Har812-23T	23	143	—	25/30/35/40

Sprocket For Har812 Top Chains

Har812型链板注塑链轮 25齿

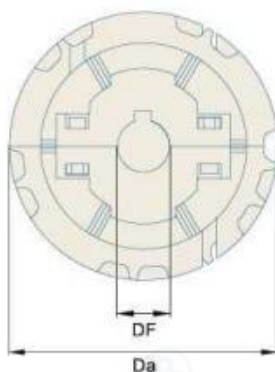
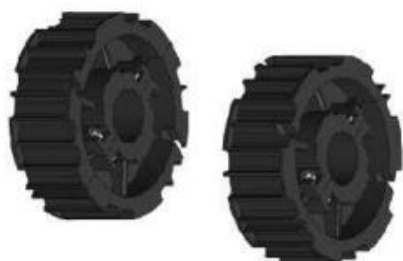

型号 Item Code	齿数 Teeth No.	外径 Da (mm)	方孔 Square Bore (mm)	圆孔 Round Bore (mm)
注塑链轮 Injection Sprocket				
Har812-25T	25	155	—	25/30/35/40

Drive Sprocket For Har812 Top Chains

Har812型主动机加工链轮

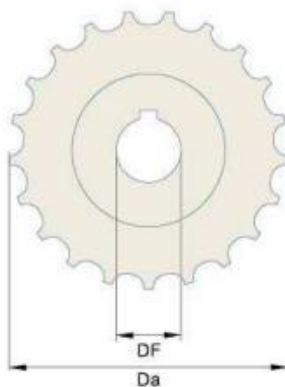

型号 Item Code	齿数 Teeth No.	外径 Da (mm)	方孔 Square Bore (mm)	圆孔 Round Bore (mm)
机加工链轮 Machined Sprocket				
Har812-19T	19	117	25/30/35	25/30/35
Har812-21T	21	129	25/30/35/40	25/30/35/40
Har812-23T	23	143	25/30/35/40	25/30/35/40
Har812-25T	25	155	25/30/35/40	25/30/35/40

Drive Sprocket For Har820 Top Chains

Har820型主动注塑分半链轮

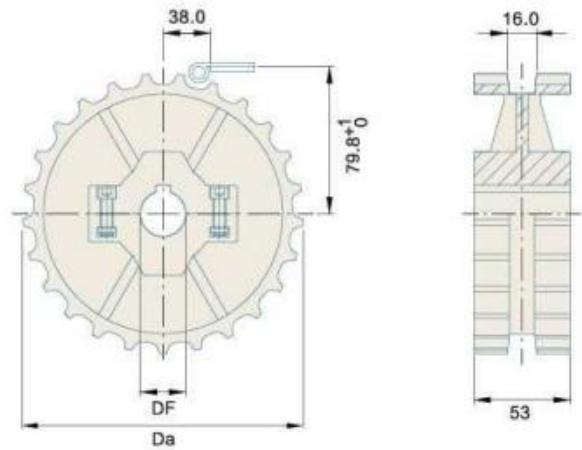

型号 Item Code	齿数 Teeth No.	外径 Da (mm)	方孔 Square Bore (mm)	圆孔 Round Bore (mm)
注塑链轮 Injection Sprocket				
Har820ZSF-19T	19	118	—	25/30
Har820ZSF-21T	21	129	—	25/30
Har820ZSF-23T	23	143	—	25/30
Har820ZSF-25T	25	155	—	25/30

Idler Sprocket For Har820 Top Chains

Har820型被动注塑链轮

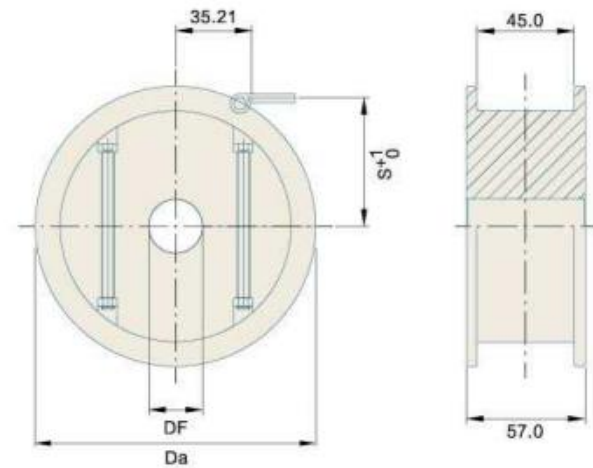

型号 Item Code	齿数 Teeth No.	外径 Da (mm)	方孔 Square Bore (mm)	圆孔 Round Bore (mm)
注塑链轮 Injection Sprocket				
Har820BZS-19T	19	118	—	25/30
Har820BZS-21T	21	129	—	25/30
Har820BZS-23T	23	143	—	25/30
Har820BZS-25T	25	155	—	25/30

Drive Sprocket For Har820 Top Chains

Har820型主动机加工链轮

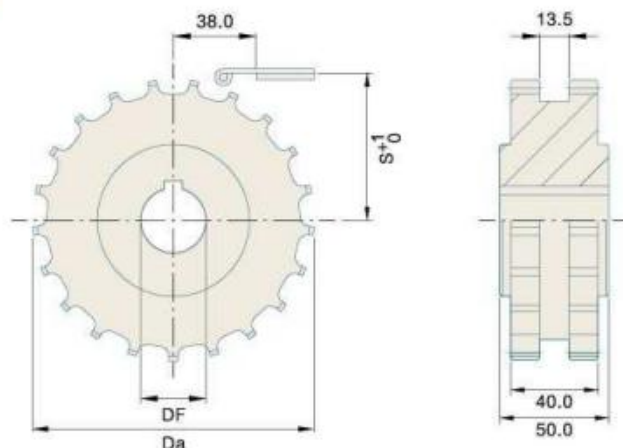

型号 Item Code	齿数 Teeth No.	外径 Da (mm)	方孔 Square Bore (mm)	圆孔 Round Bore (mm)
机加工链轮 Machined Sprocket				
Har820ZJJ-15T	15	93	—	25/30
Har820ZJJ-17T	17	107	—	25/30
Har820ZJJ-19T	19	118	—	25/30/35/40
Har820ZJJ-21T	21	129	—	25/30/35/40
Har820ZJJ-23T	23	143	—	25/30/35/40
Har820ZJJ-25T	25	155	—	25/30/35/40

Idler Sprocket For Har820 Top Chains

Har820型被动机加工链轮

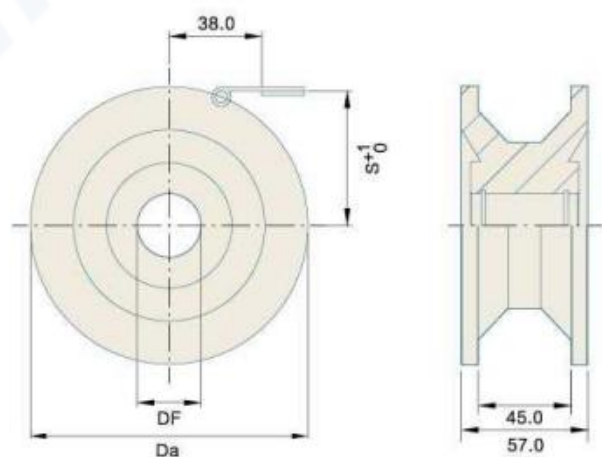

型号 Item Code	齿数 Teeth No.	外径 Da (mm)	方孔 Square Bore (mm)	圆孔 Round Bore (mm)
机加工链轮 Machined Sprocket				
Har820BJJ-15T	15	93	—	25/30
Har820BJJ-17T	17	107	—	25/30
Har820BJJ-19T	19	118	—	25/30/35/40
Har820BJJ-21T	21	129	—	25/30/35/40
Har820BJJ-23T	23	143	—	25/30/35/40
Har820BJJ-25T	25	155	—	25/30/35/40

Drive Sprocket For Har821/802 Top Chains

Har821/802型主动注塑链轮

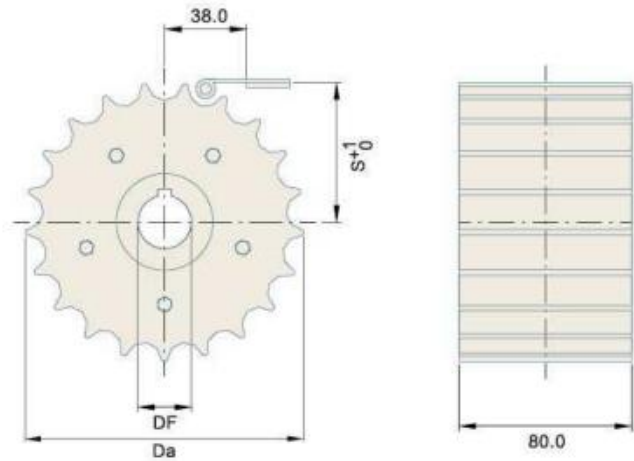

型号 Item Code	齿数 Teeth No.	外径 Da (mm)	方孔 Square Bore (mm)	圆孔 Round Bore (mm)
注塑链轮 Injection Sprocket				
Har821/802ZS-19T	19	117	—	25/30/35/40
Har821/802ZS-21T	21	129	—	25/30/35/40
Har821/802ZS-23T	23	142	—	25/30/35/40
Har821/802ZS-25T	25	154	—	25/30/35/40

Idler Sprocket For Har821/802 Top Chains

Har821/802型被动注塑链轮

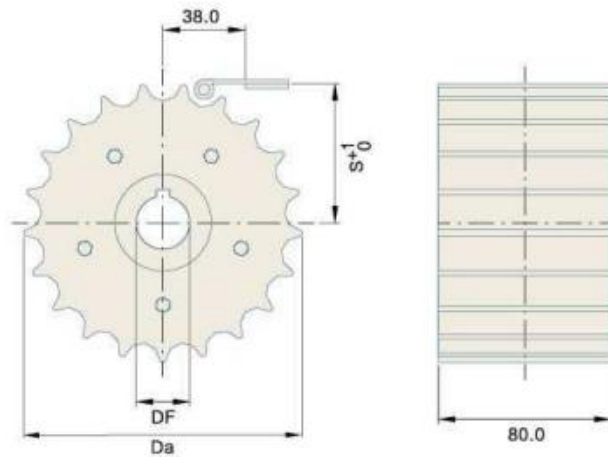

型号 Item Code	齿数 Teeth No.	外径 Da (mm)	方孔 Square Bore (mm)	圆孔 Round Bore (mm)
注塑链轮 Injection Sprocket				
Har821/802BZS-19T	19	117	—	25/30/35/40
Har821/802BZS-21T	21	129	—	25/30/35/40
Har821/802BZS-23T	23	142	—	25/30/35/40
Har821/802BZS-25T	25	154	—	25/30/35/40

Drive Sprocket For Har821/802 Top Chains

Har821/802型主动机加工链轮

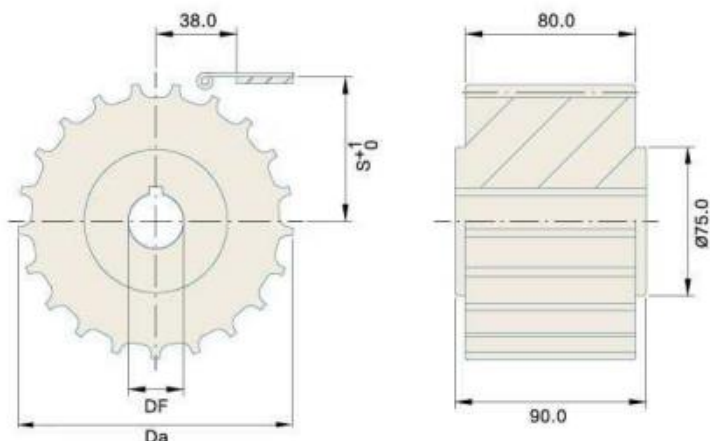

型号 Item Code	齿数 Teeth No.	外径 Da (mm)	方孔 Square Bore (mm)	圆孔 Round Bore (mm)
机加工链轮 Machined Sprocket				
Har821/802ZJJ-19T	19	117	—	25/30/35/40
Har821/802ZJJ-21T	21	129	—	25/30/35/40
Har821/802ZJJ-23T	23	142	—	25/30/35/40
Har821/802ZJJ-25T	25	154	—	25/30/35/40

Idler Sprocket For Har821/802 Top Chains

Har821/802型被动机加工链轮

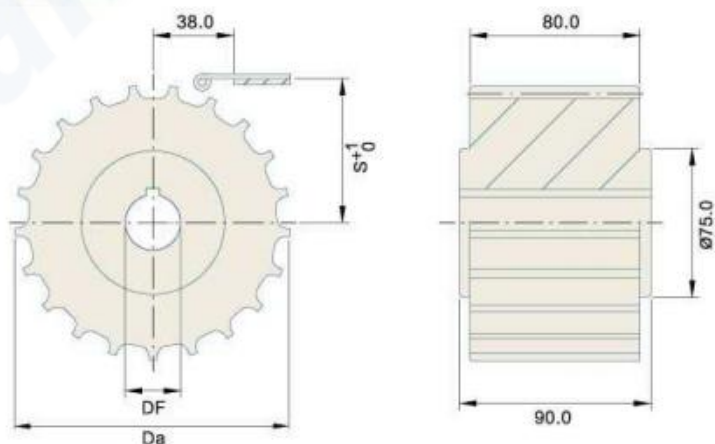

型号 Item Code	齿数 Teeth No.	外径 Da (mm)	方孔 Square Bore (mm)	圆孔 Round Bore (mm)
机加工链轮 Machined Sprocket				
Har821/802ZS-15T	15	93	—	25/30
Har821/802ZS-17T	17	107	—	25/30
Har821/802ZS-19T	19	117	—	25/30/35/40
Har821/802ZS-21T	21	129	—	25/30/35/40
Har821/802ZS-23T	23	142	—	25/30/35/40
Har821/802ZS-25T	25	154	—	25/30/35/40

Idler Sprocket For Har821/802 Top Chains

Har821/802型被动机加工链轮 无齿

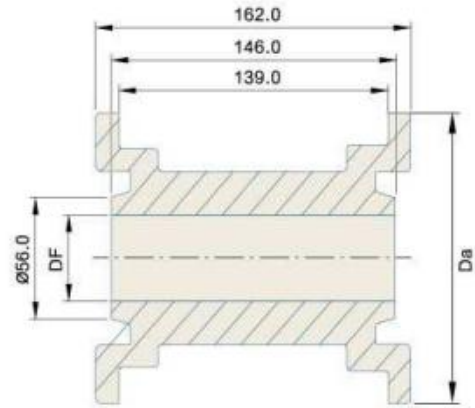

型号 Item Code	齿数 Teeth No.	外径 Da (mm)	方孔 Square Bore (mm)	圆孔 Round Bore (mm)
机加工链轮 Machined Sprocket				
Har821/802BJJC-19T	19	117	—	25/30/35/40
Har821/802BJJC-21T	21	129	—	25/30/35/40
Har821/802BJJC-23T	23	142	—	25/30/35/40
Har821/802BJJC-25T	25	154	—	25/30/35/40

Sprocket For Har830T Flexible Chains

Har830T型柔性链机加工链轮

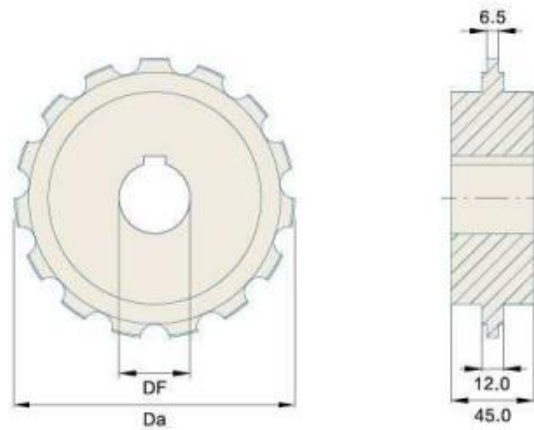

型号 Item Code	齿数 Teeth No.	外径 Da (mm)	方孔 Square Bore (mm)	圆孔 Round Bore (mm)
机加工链轮 Machined Sprocket				
Har830T-13T	13	134.5	25/30/35/40/50	25/30/35/40/50
Har830T-15T	15	152.7	25/30/35/40/50	25/30/35/40/50
Har830T-17T	17	194.8	25/30/35/40/50	25/30/35/40/50

Sprocket For Har843 Top Chains

Har843型链板机加工链轮

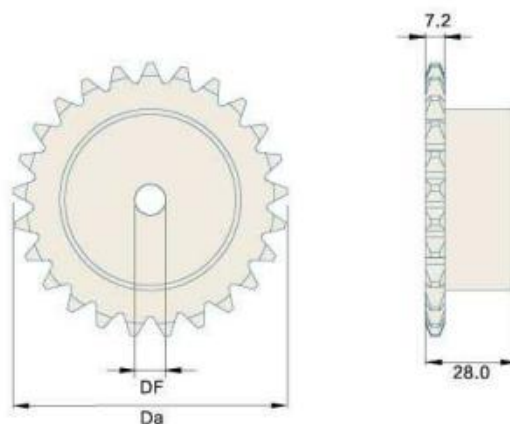

型号 Item Code	齿数 Teeth No.	外径 Da (mm)	方孔 Square Bore (mm)	圆孔 Round Bore (mm)
机加工链轮 Machined Sprocket				
Har843-19T	19	81.7	—	25/30
Har843-21T	21	89.7	—	25/30
Har843-25T	25	105.8	—	25/30/40

Drive Sprocket For Har880 Top Chains

Har880型主被动机加工链轮

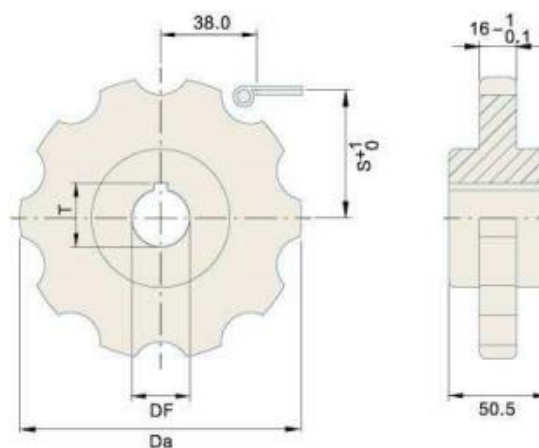

型号 Item Code	齿数 Teeth No.	外径 Da (mm)	方孔 Square Bore (mm)	圆孔 Round Bore (mm)
机加工链轮 Machined Sprocket				
Har880-9T	9	110	—	25/30
Har880-10T	10	122	—	25/30
Har880-11T	11	135	—	25/30
Har880-12T	12	147	—	25/30
Har880-15T	15	178	—	25/30

Drive&Driven Sprocket For Har880 Top Chains

Har880型链板注塑链轮 10齿

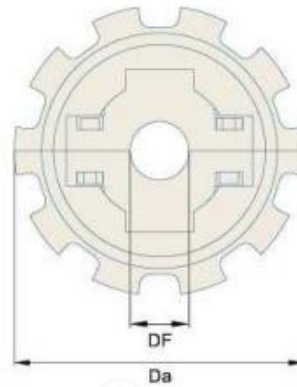

型号 Item Code	齿数 Teeth No.	外径 Da (mm)	方孔 Square Bore (mm)	圆孔 Round Bore (mm)
注塑链轮 Injection Sprocket				
Har880-10T	10	122	—	25/30/35/40

Drive&Driven Sprocket for Har880 Top Chains

Har880型链板注塑链轮 11齿

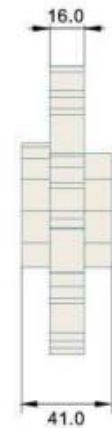
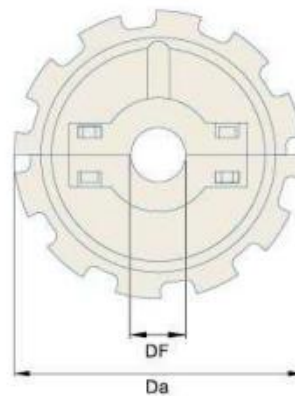

型号 Item Code	齿数 Teeth No.	外径 Da (mm)	方孔 Square Bore (mm)	圆孔 Round Bore (mm)
注塑链轮 Injection Sprocket				
Har880-11T	11	135	—	25/30/35/40
Har880-12T	12	147	—	25/30/35/40

Drive Sprocket For Har882TAB Top Chains

Har882TAB型主动注塑链轮

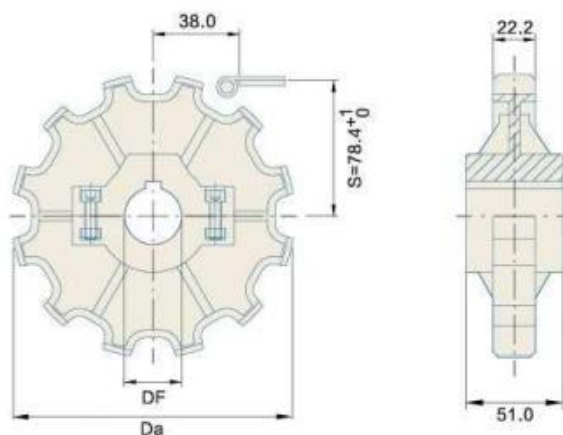

型号 Item Code	齿数 Teeth No.	外径 Da (mm)	方孔 Square Bore (mm)	圆孔 Round Bore (mm)
注塑链轮 Injection Sprocket				
Har882TABZS-9T	9	110	—	25/30
Har882TABZS-10T	10	122	—	25/30
Har882TABZS-11T	11	135	—	25/30
Har882TABZS-12T	12	147	—	25/30

Driven Sprocket For Har882TAB Top Chains

Har882TAB型被动注塑链轮

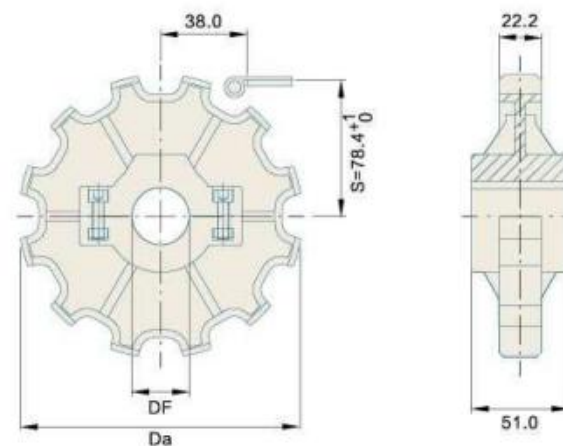

型号 Item Code	齿数 Teeth No.	外径 Da (mm)	方孔 Square Bore (mm)	圆孔 Round Bore (mm)
注塑链轮 Injection Sprocket				
Har882TABBS-9T	9	110	—	25/30
Har882TABBS-10T	10	122	—	25/30
Har882TABBS-11T	11	135	—	25/30
Har882TABBS-12T	12	147	—	25/30

Drive Sprocket For Har882 Top Chains

Har882TAB型主被动机加工链轮

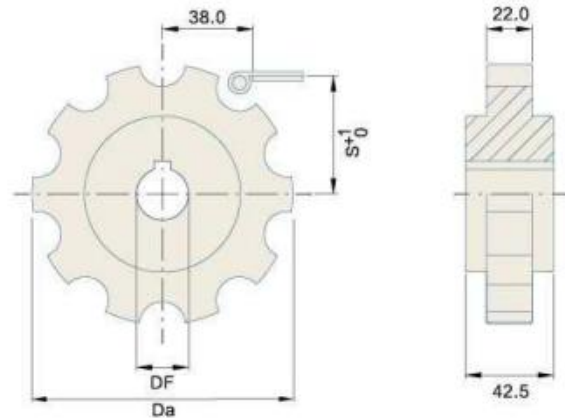

型号 Item Code	齿数 Teeth No.	外径 Da (mm)	方孔 Square Bore (mm)	圆孔 Round Bore (mm)
机加工链轮 Machined Sprocket				
Har882-9T	9	110	—	25/30
Har882-10T	10	122	—	25/30
Har882-11T	11	135	—	25/30
Har882-12T	12	147	—	25/30
Har882-15T	15	178	—	25/30

Sprocket For Har900 Modular Belt

Har900型机加工链轮

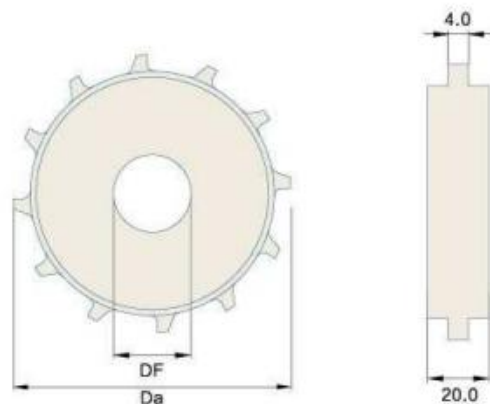

型号 Item Code	齿数 Teeth No.	外径 Da (mm)	方孔 Square Bore (mm)	圆孔 Round Bore (mm)
机加工链轮 Machined Sprocket				
Har900-12T	12	107	30/40	25/30/40

Sprocket For Har900 Modular Belt

Har900型注塑链轮

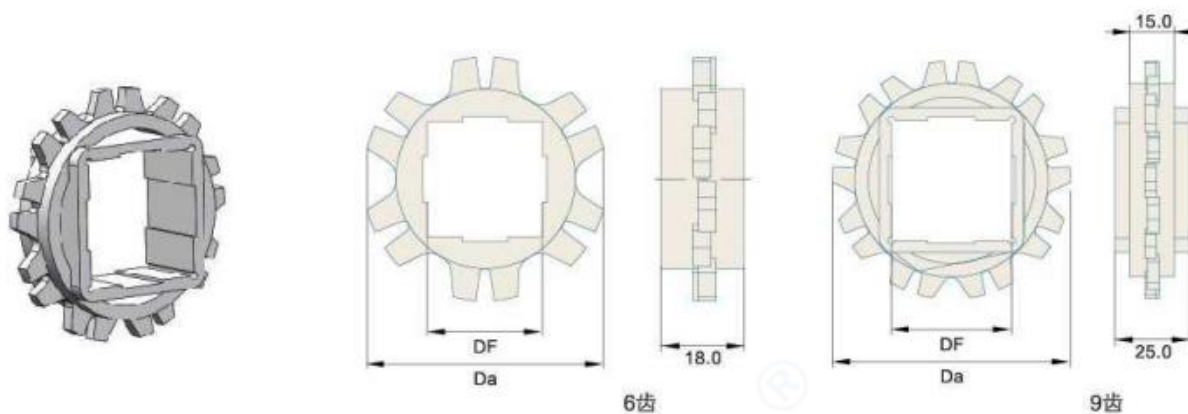

型号 Item Code	齿数 Teeth No.	外径 Da (mm)	方孔 Square Bore (mm)	圆孔 Round Bore (mm)
注塑链轮 Injection Sprocket				
Har900-6T	6	53	25	—
Har900-9T	9	79	40	25/30
Har900-10T	10	89	40	25/30

Sprocket For Har900 Modular Belt

Har900型注塑链轮 12齿

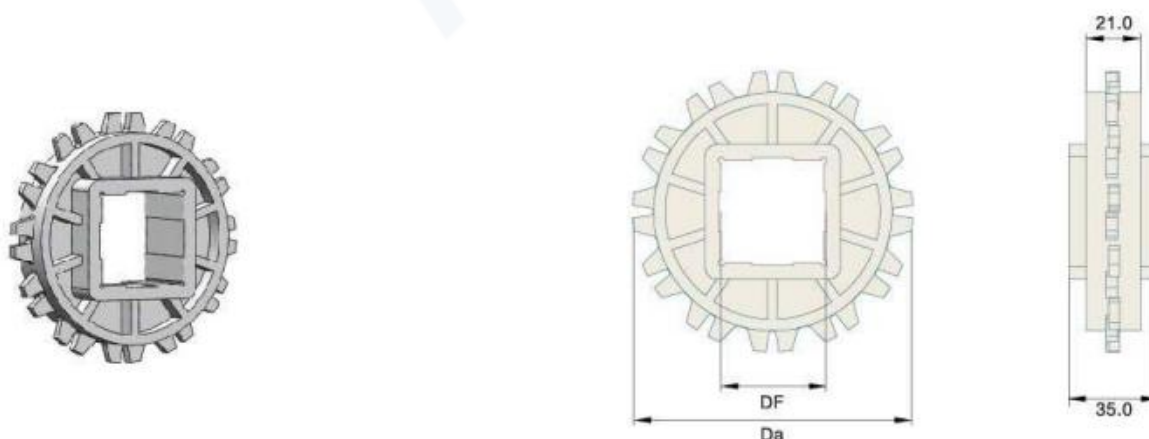

型号 Item Code	齿数 Teeth No.	外径 Da (mm)	方孔 Square Bore (mm)	圆孔 Round Bore (mm)
注塑链轮 Injection Sprocket				
Har900-12T	12	104	40	25/30

Sprocket For Har900 Modular Belt

Har900型注塑链轮 15齿

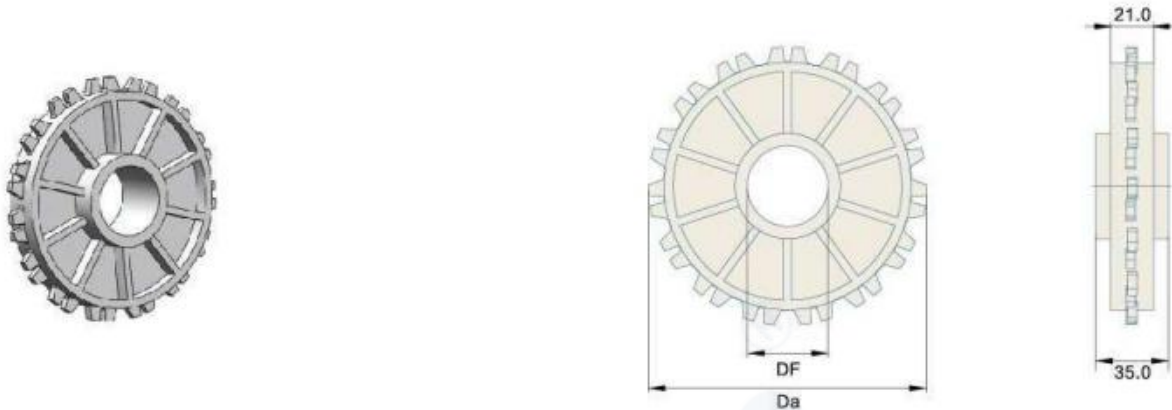

型号 Item Code	齿数 Teeth No.	外径 Da (mm)	方孔 Square Bore (mm)	圆孔 Round Bore (mm)
注塑链轮 Injection Sprocket				
Har900-15T	15	130	40	25/30

Sprocket For Har900 Modular Belt

Har900型网链注塑链轮 18齿

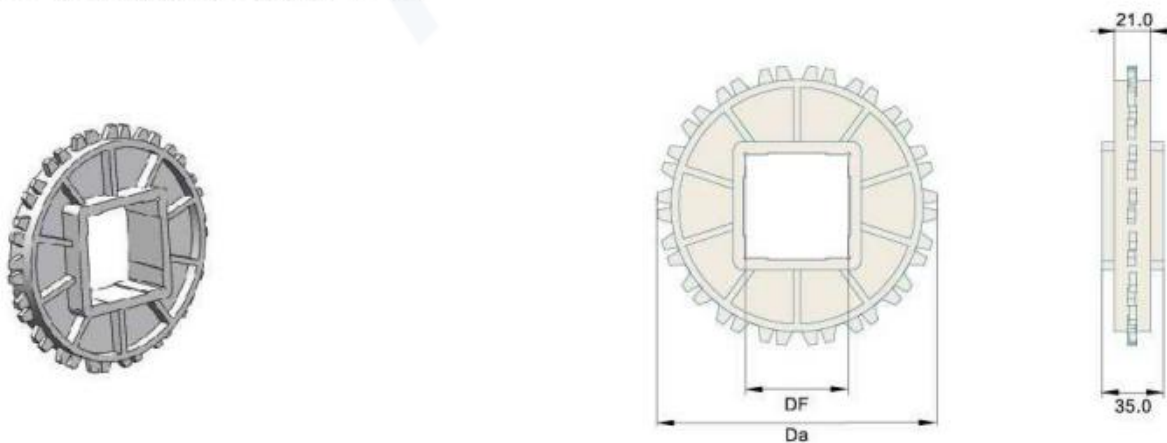

型号 Item Code	齿数 Teeth No.	外径 Da (mm)	方孔 Square Bore (mm)	圆孔 Round Bore (mm)
注塑链轮 Injection Sprocket				
Har900-18T	18	155	40/60	25/30

Sprocket For Har900 Modular Belt

Har900型网链注塑链轮 20齿

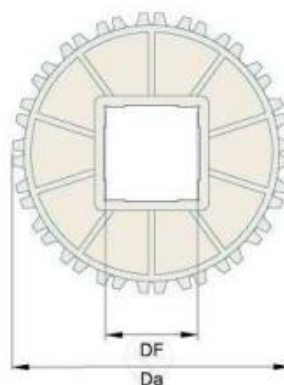

型号 Item Code	齿数 Teeth No.	外径 Da (mm)	方孔 Square Bore (mm)	圆孔 Round Bore (mm)
注塑链轮 Injection Sprocket				
Har900-20T	20	173	40/60	25/30

Sprocket For Har981TAB Top Chains

Har981TAB型链板机加工链轮

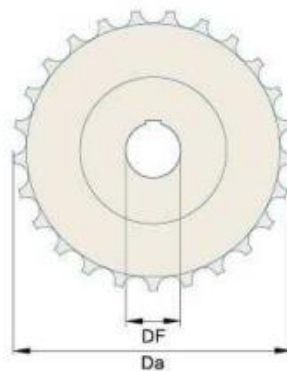

型号 Item Code	齿数 Teeth No.	外径 Da (mm)	方孔 Square Bore (mm)	圆孔 Round Bore (mm)
机加工链轮 Machined Sprocket				
Har981TAB-19T	19	115	—	25/30/35
Har981TAB-21T	21	129	—	25/30/35/40
Har981TAB-23T	23	143	—	25/30/35/40
Har981TAB-25T	25	152.5	—	25/30/35/40

Sprocket For Har1000 Modular Belt

Har1000型网链注塑链轮 整体

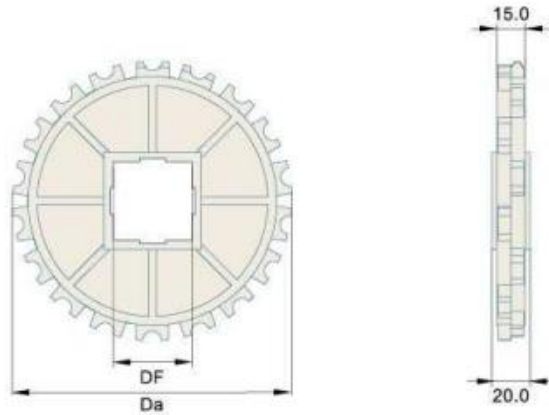

型号 Item Code	齿数 Teeth No.	外径 Da (mm)	方孔 Square Bore (mm)	圆孔 Round Bore (mm)
注塑链轮 Injection Sprocket				
Har1000-12T	12	98	30	25/30
Har1000-16T	16	132	30	25/30/40
Har1000-18T	18	146	30/40	30/35/40
Har1000-19T	19	158.8	30/40	30/35/40
Har1000-20T	20	162	30/40	30/40/50

Sprocket For Har1000 Modular Belt

Har1000型注塑链轮 分半 16齿

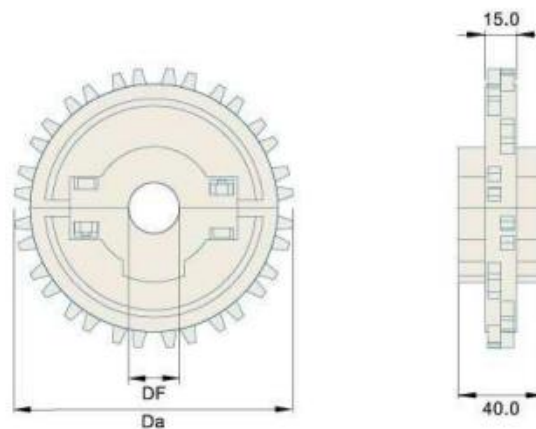

型号 Item Code	齿数 Teeth No.	外径 Da (mm)	方孔 Square Bore (mm)	圆孔 Round Bore (mm)
注塑链轮 Injection Sprocket				
Har1000-16T	16	132	—	40

Sprocket For Har1000 Modular Belt

Har1000型注塑链轮 分半 18齿

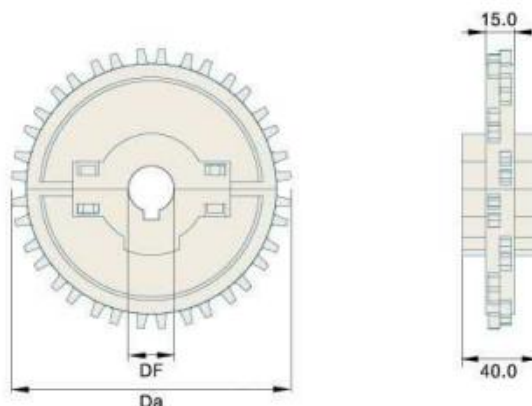

型号 Item Code	齿数 Teeth No.	外径 Da (mm)	方孔 Square Bore (mm)	圆孔 Round Bore (mm)
注塑链轮 Injection Sprocket				
Har1000-18T	18	146	—	40

Sprocket For Har1005 Modular Belt

Har1005型机加工链轮

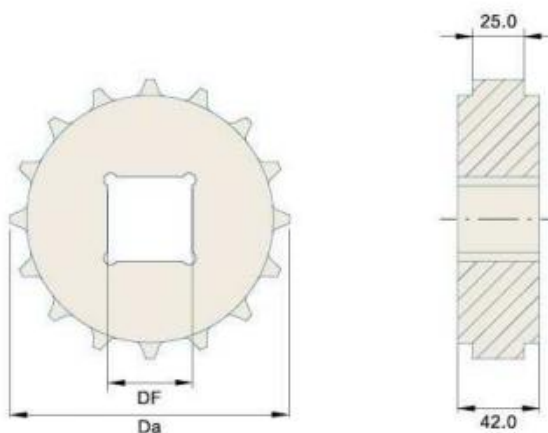

型号 Item Code	齿数 Teeth No.	外径 Da (mm)	方孔 Square Bore (mm)	圆孔 Round Bore (mm)
机加工链轮 Machined Sprocket				
Har1005-14T	14	114	20-40	20-40
Har1005-16T	16	129	20-50	20-50
Har1005-18T	18	149.6	25-60	25-60
Har1005-20T	20	162.5	30-60	30-60

Sprocket For Har1005 Modular Belt

Har1005型注塑链轮 18齿

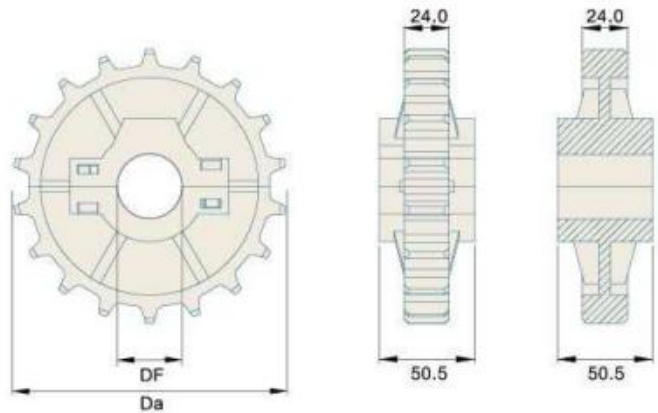

型号 Item Code	齿数 Teeth No.	外径 Da (mm)	方孔 Square Bore (mm)	圆孔 Round Bore (mm)
注塑链轮 Injection Sprocket				
Har1005-18T	18	146	—	40

Sprocket For Har1050 Top Chains

Har1050型链板主动机加工链轮

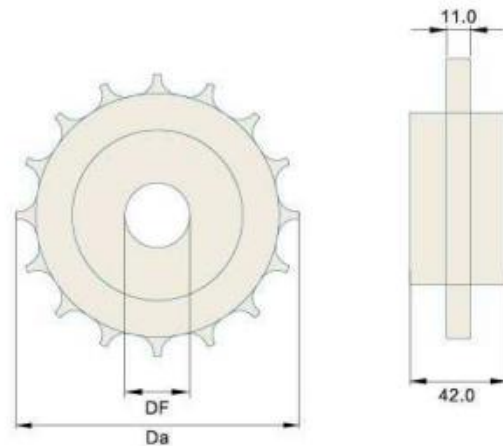

型号 Item Code	齿数 Teeth No.	外径 Da (mm)	方孔 Square Bore (mm)	圆孔 Round Bore (mm)
机加工链轮 Machined Sprocket				
Har1050-16T	16	130	20/25/30/40	20/25/30/40
Har1050-18T	18	146	20/25/30/40	20/25/30/40
Har1050-19T	19	154.5	20/25/30/40	20/25/30/40
Har1050-21T	21	170	20/25/30/40	20/25/30/40

Sprocket For Har1050 Modular Belt

Har1050型注塑链轮 16齿

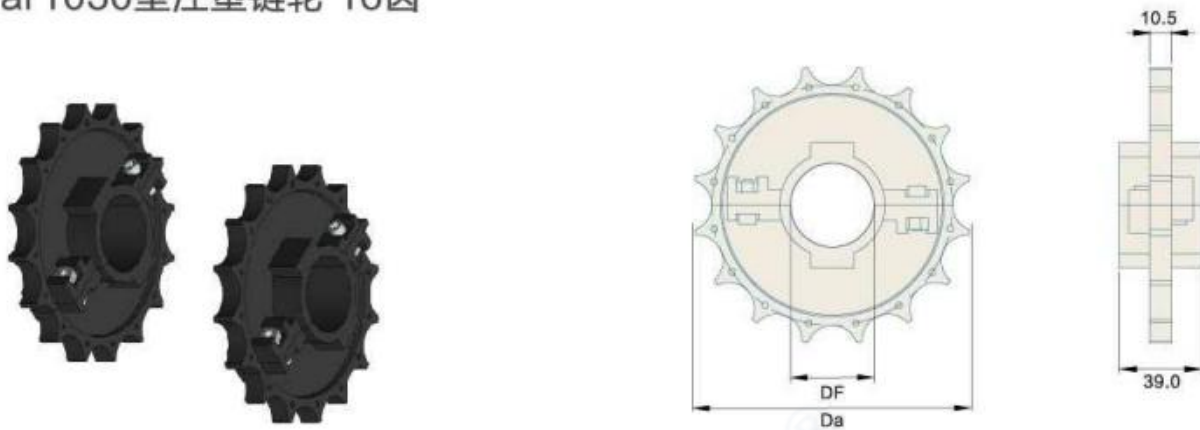

型号 Item Code	齿数 Teeth No.	外径 Da (mm)	方孔 Square Bore (mm)	圆孔 Round Bore (mm)
注塑链轮 Injection Sprocket				
Har1050-16T	16	130	—	40

Sprocket For Har1100 Modular Belt

Har1100型机加工链轮 18齿

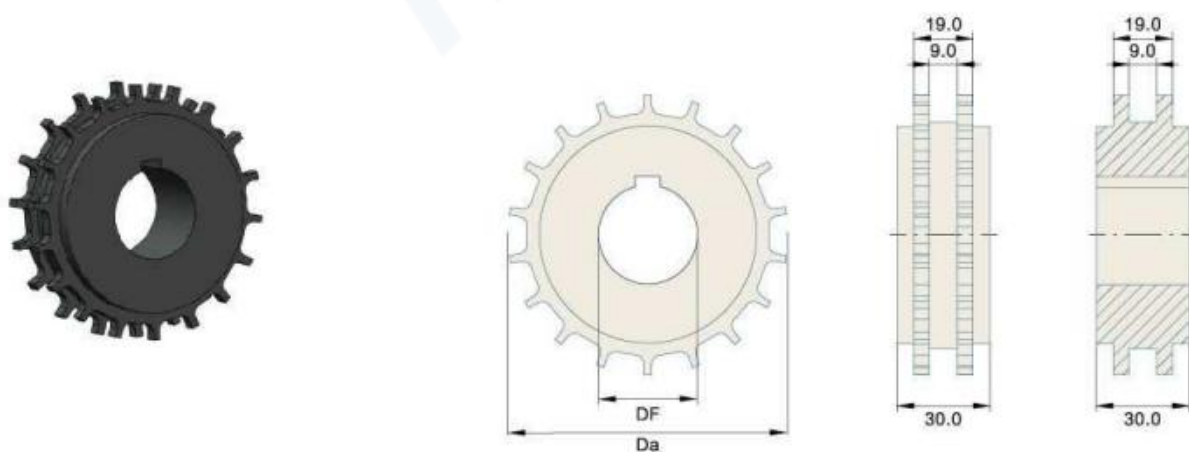

型号 Item Code	齿数 Teeth No.	外径 Da (mm)	方孔 Square Bore (mm)	圆孔 Round Bore (mm)
机加工链轮 Machined Sprocket				
Har1100-18T	18	90	40	20/30/32

Sprocket For Har1100 Modular Belt

Har1100型网链注塑链轮 分半

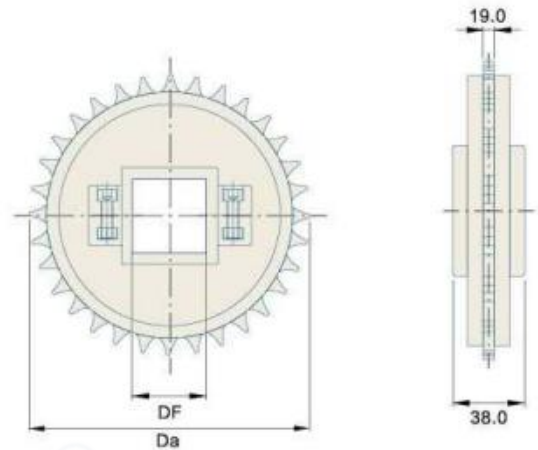

型号 Item Code	齿数 Teeth No.	外径 Da (mm)	方孔 Square Bore (mm)	圆孔 Round Bore (mm)
注塑链轮 Split type Injection Sprocket				
Har1100-32T	32	157	40	25/30/35

Sprocket For Har1100 Modular Belt

Har1100型网链板注塑链轮

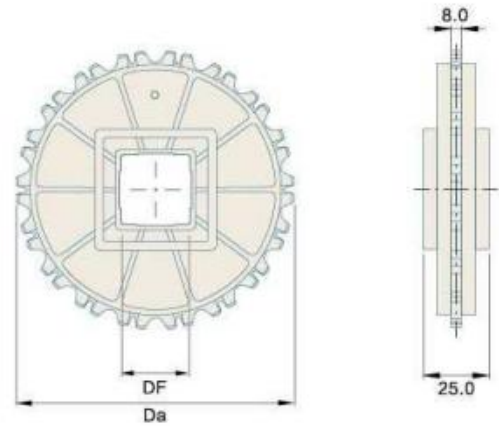

型号 Item Code	齿数 Teeth No.	外径 Da (mm)	方孔 Square Bore (mm)	圆孔 Round Bore (mm)
注塑链轮 Injection Sprocket				
Har1100-16T	16	78	40	20/25/30/40
Har1100-18T	18	87	40	20/25/30/40
Har1100-20T	20	97	40	20/25/30/40
Har1100-24T	24	117	40	20/25/30/40
Har1100-32T	32	157	40	20/25/30/40

Sprocket For Har1270 Modular Belt

Har1270型网链机注塑链轮

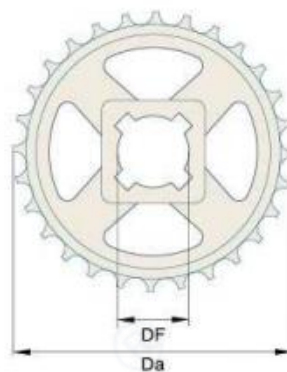

型号 Item Code	齿数 Teeth No.	外径 Da (mm)	方孔 Square Bore (mm)	圆孔 Round Bore (mm)
注塑链轮 Injection Sprocket				
Har1270-28T	28	116.6	—	30

Sprocket For Har1400 /1400TAB Flexible Chains

Har1400/1400TAB型柔性链机加工链轮

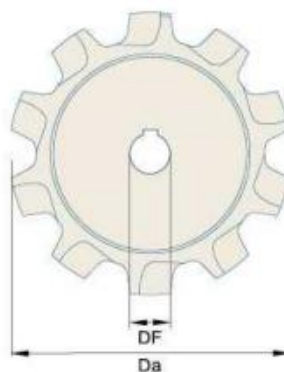

型号 Item Code	齿数 Teeth No.	外径 Da (mm)	方孔 Square Bore (mm)	圆孔 Round Bore (mm)
机加工链轮 Machined Sprocket				
Har1400-6T	6	176	25-50	25-50
Har1400-8T	8	226	25-60	25-60
Har1400-10T	10	278	25-60	25-60

Sprocket For Har1400 Modular Belt

Har1400型网链机加工链轮

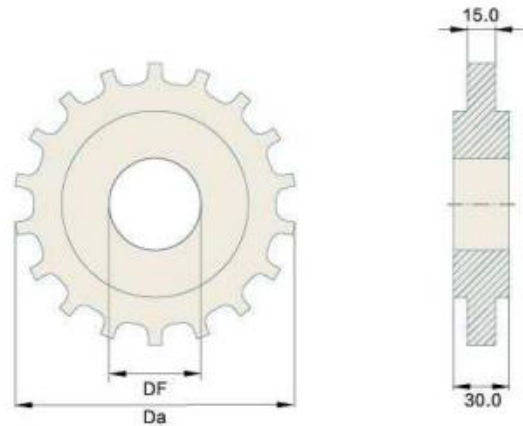

型号 Item Code	齿数 Teeth No.	外径 Da (mm)	方孔 Square Bore (mm)	圆孔 Round Bore (mm)
机加工链轮 Machined Sprocket				
Har1400-16T	16	134	20-40	25-40
Har1400-18T	18	151	20-40	25-40
Har1400-21T	21	176	30-60	30-60
Har1400-31T	31	251	30-60	30-60

Sprocket For Har1400 Modular Belt

Har1400型网链注塑链轮

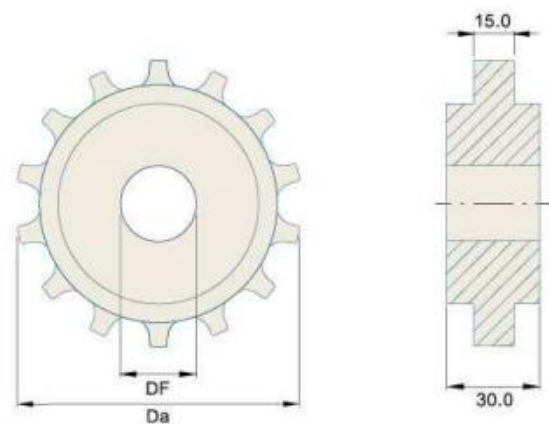

型号 Item Code	齿数 Teeth No.	外径 Da (mm)	方孔 Square Bore (mm)	圆孔 Round Bore (mm)
注塑链轮 Injection Sprocket				
Har1400-21T	21	171	—	50

Sprocket For Har1500 Modular Belt

Har1500型网链机加工链轮

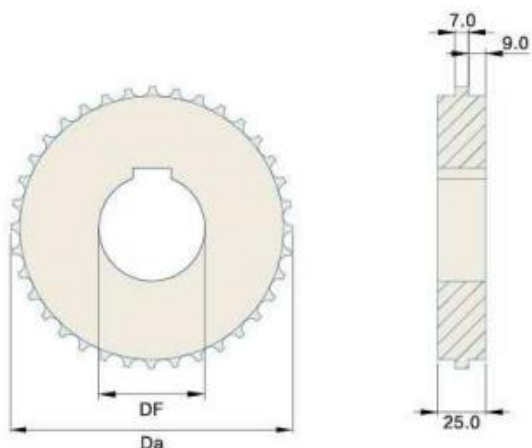

型号 Item Code	齿数 Teeth No.	外径 Da (mm)	方孔 Square Bore (mm)	圆孔 Round Bore (mm)
机加工链轮 Machined Sprocket				
Har1500-19T	19	79	20-40	20-40
Har1500-20T	20	82	20-40	20-40
Har1500-28T	28	114.2	25-60	25-60
Har1500-38T	38	157.4	30-70	30-70

Sprocket For Har1505 Modular Belt

Har1505型网链机加工链轮

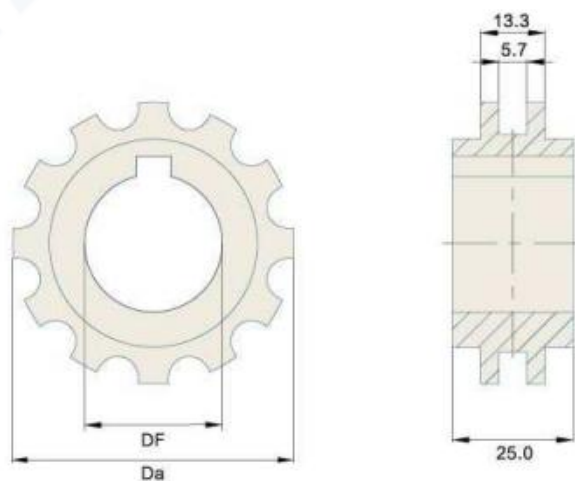

型号 Item Code	齿数 Teeth No.	外径 Da (mm)	方孔 Square Bore (mm)	圆孔 Round Bore (mm)
机加工链轮 Machined Sprocket				
Har1505-16T	16	77.7	20-35	20-35
Har1505-24T	24	115.5	20-60	20-60
Har1505-32T	32	154.8	30-60	30-60
Har1505-36T	36	157	30-60	30-60

Sprocket For Har1506 Modular Belt

Har1506型网链机加工链轮

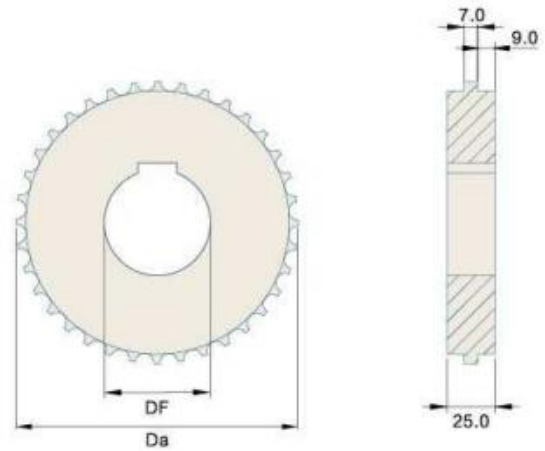

型号 Item Code	齿数 Teeth No.	外径 Da (mm)	方孔 Square Bore (mm)	圆孔 Round Bore (mm)
机加工链轮 Machined Sprocket				
Har1506-14T	14	58	—	15-25
Har1506-19T	19	79	20-40	20-40
Har1506-20T	20	82	20-40	20-40
Har1506-28T	28	114.2	25-60	25-60
Har1506-32T	32	154.8	30-60	30-60
Har1506-36T	36	157	30-60	30-60

Sprocket For Har1507 Modular Belt

Har1507型网链机加工链轮

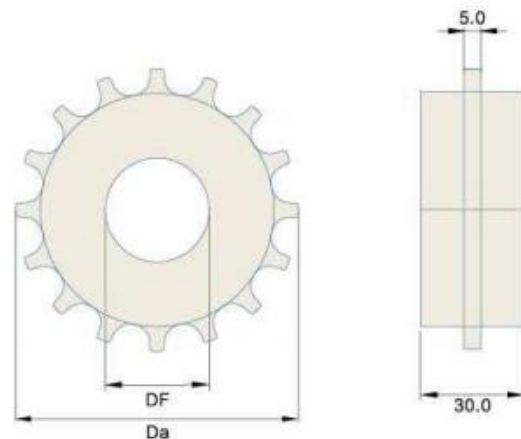

型号 Item Code	齿数 Teeth No.	外径 Da (mm)	方孔 Square Bore (mm)	圆孔 Round Bore (mm)
机加工链轮 Machined Sprocket				
Har1507-16T	16	81.6	25/30	25/30
Har1507-24T	24	121	30	25-60
Har1507-32T	32	162	30/40	25-60

Sprocket For Har1600 Modular Belt

Har1600型网链机加工链轮

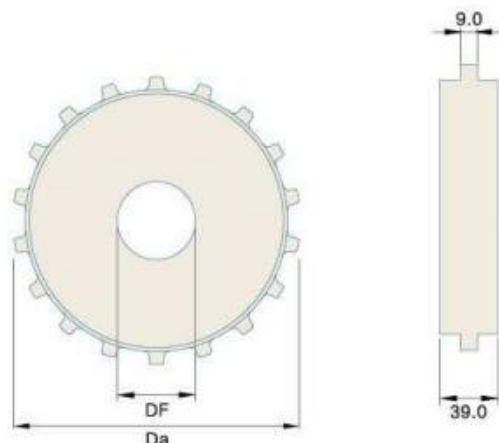

型号 Item Code	齿数 Teeth No.	外径 Da (mm)	方孔 Square Bore (mm)	圆孔 Round Bore (mm)
机加工链轮 Machined Sprocket				
Har1600-8T	8	64.51	—	20-30
Har1600-10T	10	81.3	—	25-35
Har1600-18T	18	147.2	40	30-60
Har1600-21T	21	171.6	40	30-60

Sprocket For Har1600T Modular Belt

Har1600T型网链机加工链轮

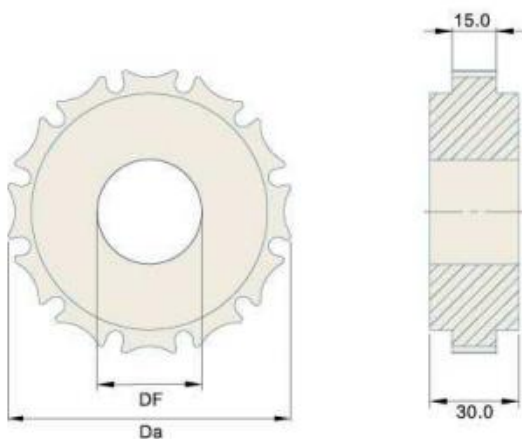

型号 Item Code	齿数 Teeth No.	外径 Da (mm)	方孔 Square Bore (mm)	圆孔 Round Bore (mm)
机加工链轮 Machined Sprocket				
Har1600T-10T	10	80.8	30	25/30/40
Har1600T-12T	12	97	30/40	25/30/40
Har1600T-15T	15	120	30/40	25/30/40

Sprocket For Har1610 Flexible Chains

Har1610型柔性链机加工链轮

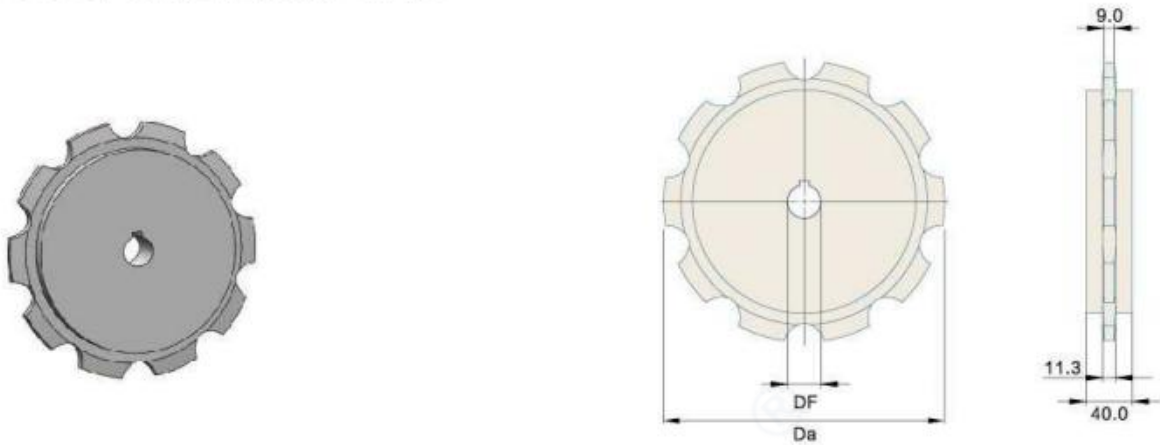

型号 Item Code	齿数 Teeth No.	外径 Da (mm)	方孔 Square Bore (mm)	圆孔 Round Bore (mm)
机加工链轮 Machined Sprocket				
Har1610-10T	10	203	—	40/50

Sprocket For Har1700 Flexible Chains

Har1700型柔性链机加工链轮

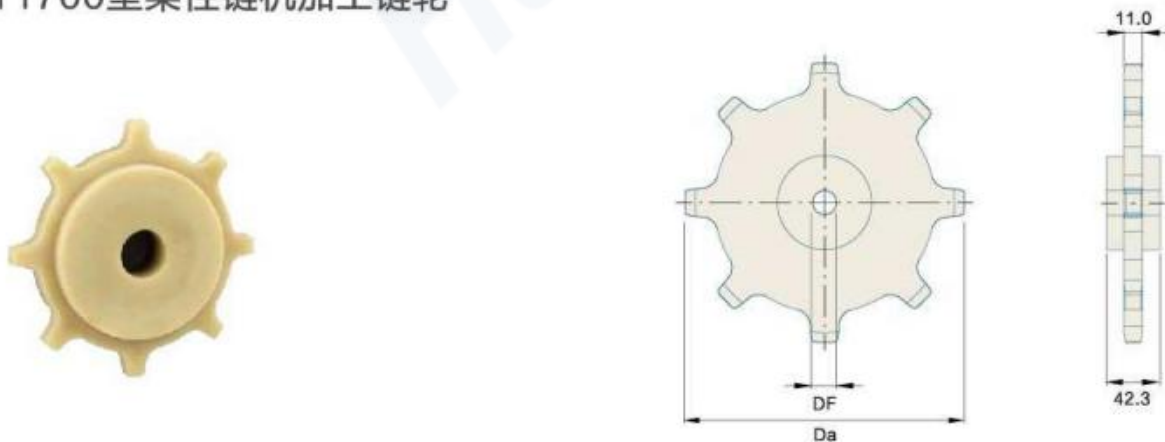

型号 Item Code	齿数 Teeth No.	外径 Da (mm)	方孔 Square Bore (mm)	圆孔 Round Bore (mm)
机加工链轮 Machined Sprocket				
Har1700-8T	8	133	20/25/30	20/25/30
Har1700-10T	10	166	25/30/40	25/30/40
Har1700-12T	12	196	25/30/40	25/30/40

Sprocket For Har1700T Modular Belt

Har1700T型网链机加工链轮

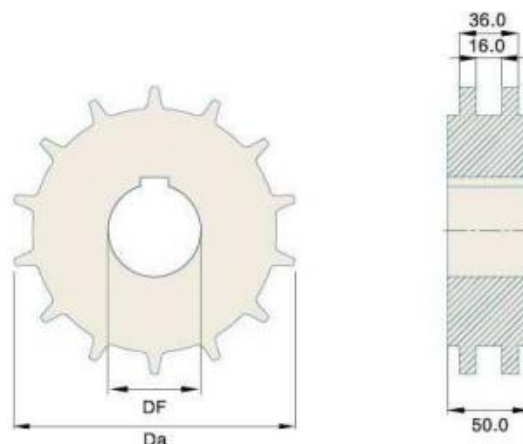

型号 Item Code	齿数 Teeth No.	外径 Da (mm)	方孔 Square Bore (mm)	圆孔 Round Bore (mm)
机加工链轮 Machined Sprocket				
Har1700T-12T	12	147	30 /35 /40	30/35/40
Har1700T-14T	14	174	40/ 45/ 50	40/45/50
Har1700T-16T	16	201.5	40 /50 /60	40/50/60

Sprocket For Har1873 Roller Chains

Har1873型滚子链机加工链轮

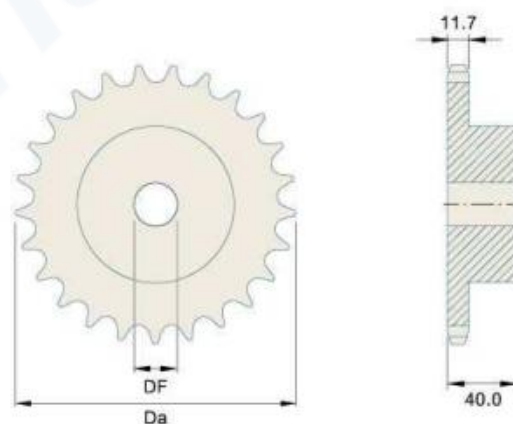

型号 Item Code	齿数 Teeth No.	外径 Da (mm)	方孔 Square Bore (mm)	圆孔 Round Bore (mm)
机加工链轮 Machined Sprocket				
Har1873-21T	21	136	20	20
Har1873-23T	23	148	20	20
Har1873-25T	25	160	20	20
Har1873-27T	27	172	20	20
Har1873-29T	29	184	20	20
Har1873-31T	31	196	25	25
Har1873-33T	33	209	25	25
Har1873-35T	35	221	25	25
Har1873-37T	37	233	25	25

Sprocket For Har1900A Flexible Chains

Har1900A型柔性链机加工链轮

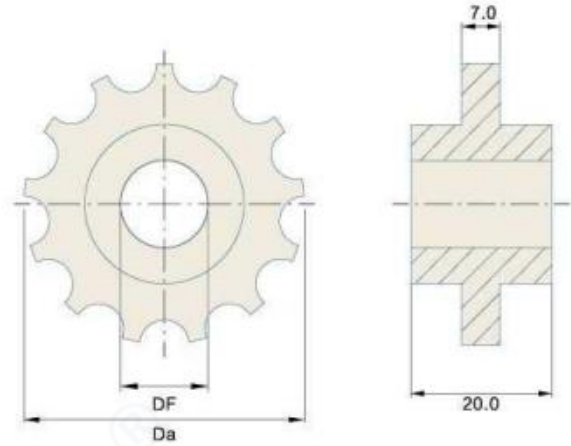

型号 Item Code	齿数 Teeth No.	外径 Da (mm)	方孔 Square Bore (mm)	圆孔 Round Bore (mm)
机加工链轮 Machined Sprocket				
Har1900A-15T	15	62.8	—	25/30

Sprocket For Har1900B Flexible Chains

Har1900B型柔性链机加工链轮

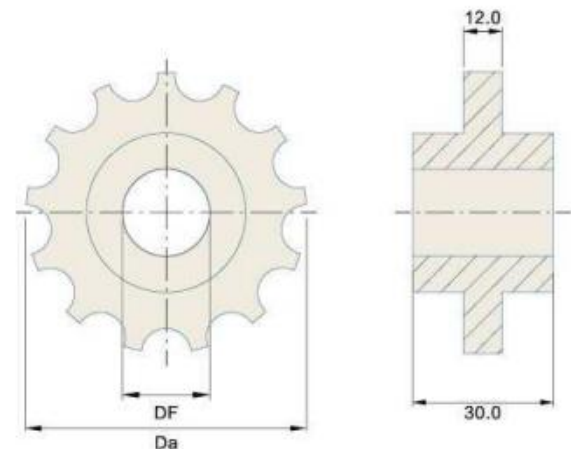

型号 Item Code	齿数 Teeth No.	外径 Da (mm)	方孔 Square Bore (mm)	圆孔 Round Bore (mm)
机加工链轮 Machined Sprocket				
Har1900B-19T	19	118.5	—	25/30/35/40

Sprocket For Har2000 Flexible Chains

Har2000型柔性链机加工链轮

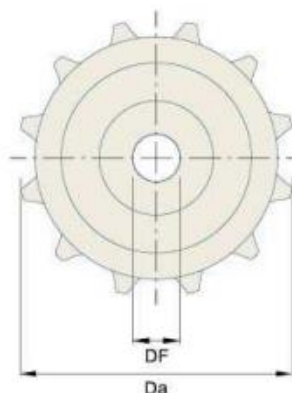

型号 Item Code	齿数 Teeth No.	外径 Da (mm)	方孔 Square Bore (mm)	圆孔 Round Bore (mm)
机加工链轮 Machined Sprocket				
Har2000-10T	10	122	20/25/30	20/25/30
Har2000-11T	11	134	20/25/30	20/25/30
Har2000-12T	12	146	20/25/30	20/25/30

Sprocket For Har2100 Modular Belt

Har2100型网链机加工链轮

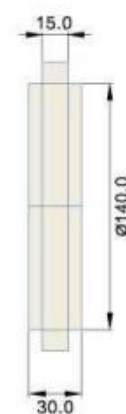
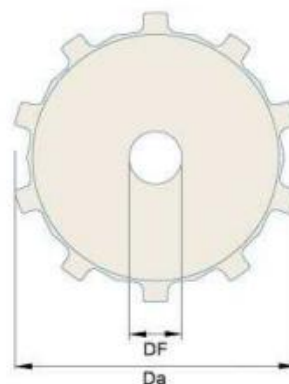

型号 Item Code	齿数 Teeth No.	外径 Da (mm)	方孔 Square Bore (mm)	圆孔 Round Bore (mm)
机加工链轮 Machined Sprocket				
Har2100-10T	10	164.4	40/50	40/50

Sprocket For Har2120 Modular Belt

Har2120型网链机加工链轮

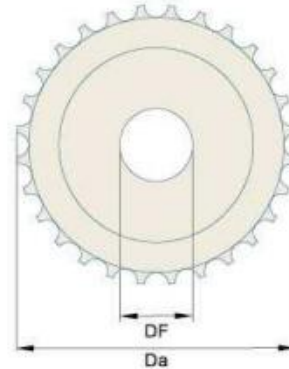

型号 Item Code	齿数 Teeth No.	外径 Da (mm)	方孔 Square Bore (mm)	圆孔 Round Bore (mm)
机加工链轮 Machined Sprocket				
Har2120-24T	24	99.3	30/40	30/40
Har2120-28T	28	115	30/40	30/40
Har2120-32T	32	129	30/40	30/40/50
Har2120-36T	36	148	30/40/50	30/40/50

Sprocket For Har2120 Modular Belt

Har2120型注塑链轮

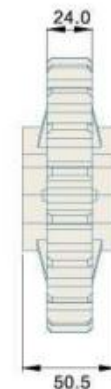
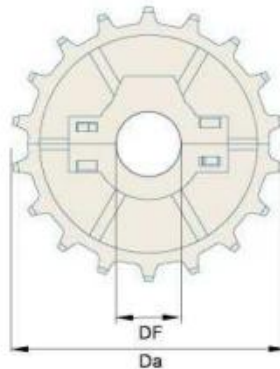

型号 Item Code	齿数 Teeth No.	外径 Da (mm)	方孔 Square Bore (mm)	圆孔 Round Bore (mm)
注塑链轮 Injection Sprocket				
Har2120-28T	28	115.4	—	30/40
Har2120-36T	36	147.7	—	30/40

Sprocket For Har2200 Modular Belt

Har2200型网链机加工链轮

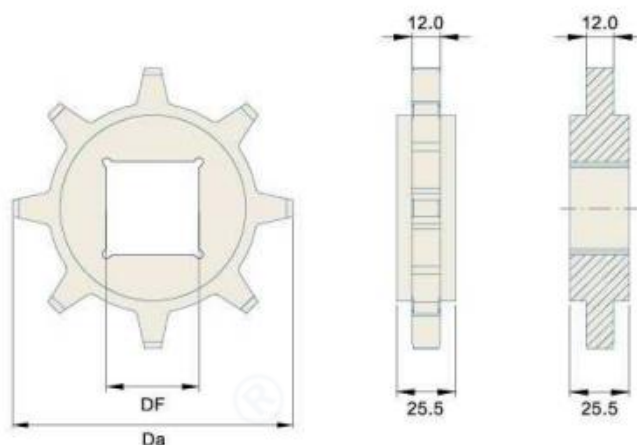

型号 Item Code	齿数 Teeth No.	外径 Da (mm)	方孔 Square Bore (mm)	圆孔 Round Bore (mm)
机加工链轮 Machined Sprocket				
Har2200-8T	8	120	25/30/40	25/30/40
Har2200-10T	10	151	25/30/40	25/30/40

Sprocket For Har1800 Flexible Chains

Har1800型柔性链机加工链轮

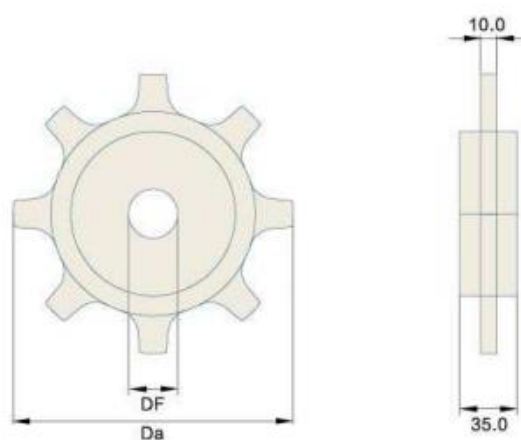

型号 Item Code	齿数 Teeth No.	外径 Da (mm)	方孔 Square Bore (mm)	圆孔 Round Bore (mm)
机加工链轮 Machined Sprocket				
Har1800-8T	8	170	25/30/40	25/30/40

Sprocket For Har2265/Har2275 Modular Belt

Har2265/Har2275型机加工链轮

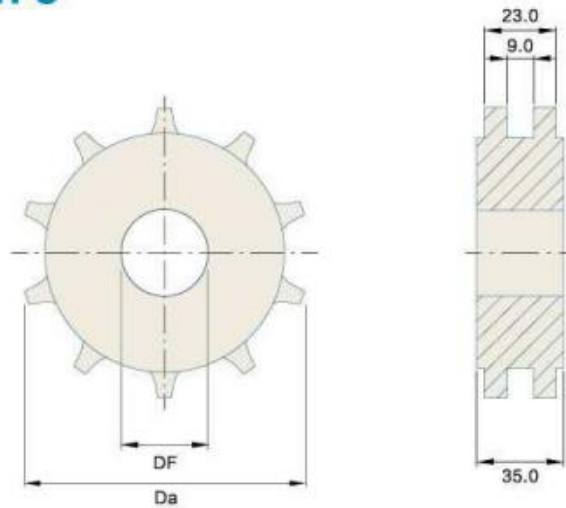

型号 Item Code	齿数 Teeth No.	外径 Da (mm)	方孔 Square Bore (mm)	圆孔 Round Bore (mm)
机加工链轮 Machined Sprocket				
Har2265/Har2275-10T	10	106.6	30/40	30/40
Har2265/Har2275-13T	13	132	30/40	30/40
Har2265/Har2275-15T	15	155	30/40	30/40
Har2265/Har2275-16T	16	163	30/40	30/40

Sprocket For Har1100 Roller Top Modular Belt

Har1100型滚珠网链机加工链轮

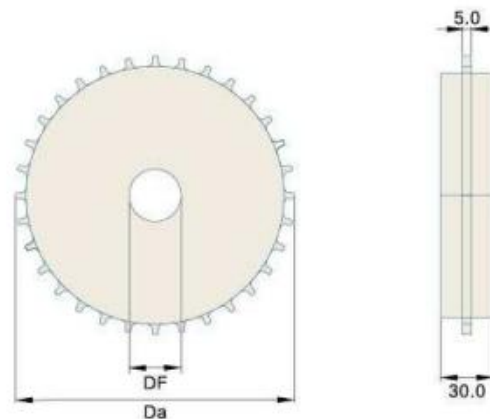

型号 Item Code	齿数 Teeth No.	外径 Da (mm)	方孔 Square Bore (mm)	圆孔 Round Bore (mm)
机加工链轮 Machined Sprocket				
Har1100R-16T	16	82	25/30	25/30
Har1100R-20T	20	100	30/40	30/40
Har1100R-32T	32	160	30/40/50	30/40/50

Sprocket For Har2350PW Flexible Chains

Har2350PW型主动机加工链轮

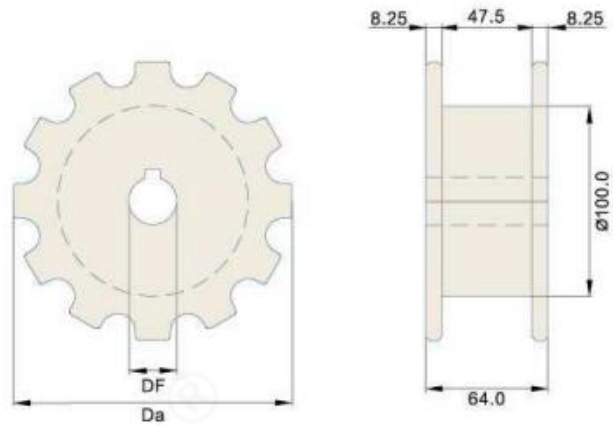

型号 Item Code	齿数 Teeth No.	外径 Da (mm)	方孔 Square Bore (mm)	圆孔 Round Bore (mm)
机加工链轮 Machined Sprocket				
Har2350PW-12T	12	146.3	—	25/30/40

备注：适用于Har2350PW-k406柔性链。

Sprocket For Har2350PW Flexible Chains

Har2350PW型被动机加工链轮

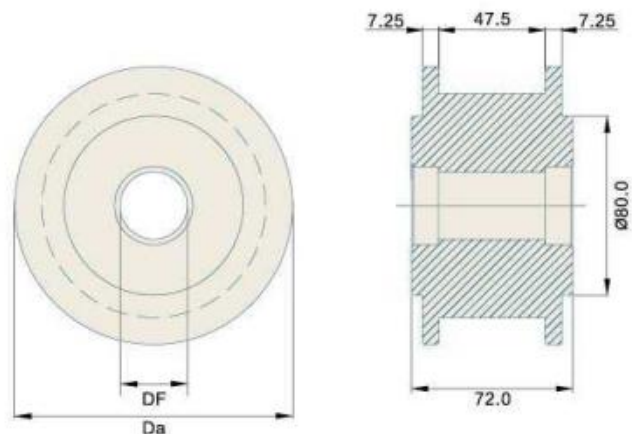

型号 Item Code	齿数 Teeth No.	外径 Da (mm)	方孔 Square Bore (mm)	圆孔 Round Bore (mm)
机加工链轮 Machined Sprocket				
Har2350PW-12T	12	124	—	25/30/40

备注：适用于Har2350PW-k406, 2350PW-103柔性链。

Sprocket For Har2350PW Flexible Chains

Har2350PW型机加工链轮

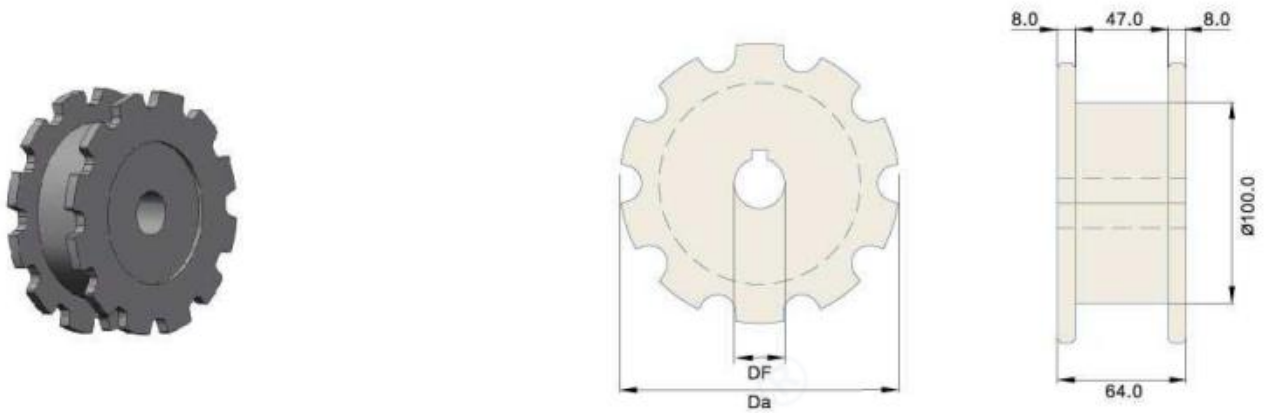

型号 Item Code	齿数 Teeth No.	外径 Da (mm)	方孔 Square Bore (mm)	圆孔 Round Bore (mm)
机加工链轮 Machined Sprocket				
Har2350PW-12T	12	139	—	25/30/40

备注：适用于Har2350PW-103柔性链。

Idler Sprocket For Har2350PW Flexible Chains

Har2350PW型主被动机加工链轮

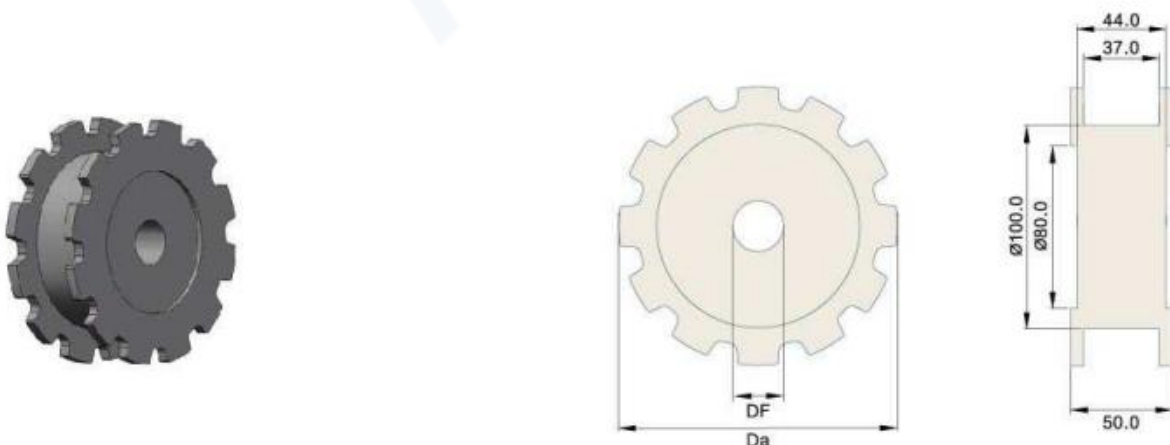

型号 Item Code	齿数 Teeth No.	外径 Da (mm)	方孔 Square Bore (mm)	圆孔 Round Bore (mm)
机加工链轮 Machined Sprocket				
Har2350PW-12T	12	136.8	—	25/30/40

备注：适用于Har2350PW-k327, 2350PW-83柔性链。

Sprocket For Har2350PW Flexible Chains

Har2350PW型柔性链注塑链轮

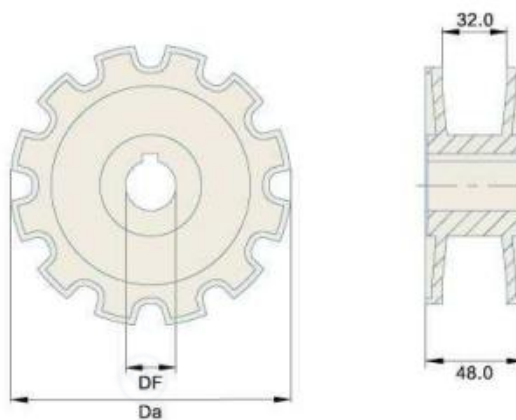

型号 Item Code	齿数 Teeth No.	外径 Da (mm)	方孔 Square Bore (mm)	圆孔 Round Bore (mm)
注塑链轮 Injection Sprocket				
Har2350PW-12T	12	138	—	25

备注：适用于Har2350PW-k327柔性链。

Sprocket For Har2350PW Flexible Chains

Har2350PW型柔性链被动注塑链轮

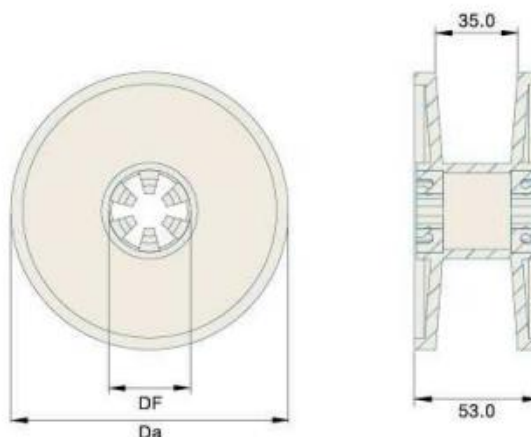

型号 Item Code	齿数 Teeth No.	外径 Da (mm)	方孔 Square Bore (mm)	圆孔 Round Bore (mm)
注塑链轮 Injection Sprocket				
Har2350PW-12T	12	117	—	25

备注：适用于Har2350PW-k327柔性链。

Sprocket For Har2350PW-83 Modular Belt

Har2350PW-83型柔性链链轮

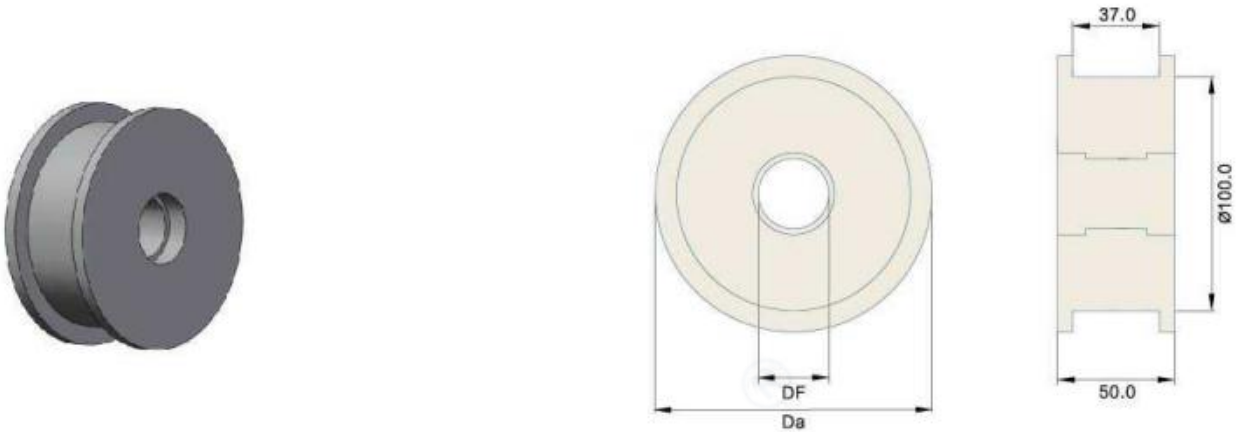

型号 Item Code	齿数 Teeth No.	外径 Da (mm)	方孔 Square Bore (mm)	圆孔 Round Bore (mm)
机加工链轮 Machined Sprocket				
Har2350PW-83-12T	12	117	25/30	25/30

Sprocket For Har2400 Modular Belt

Har2400型注塑链轮

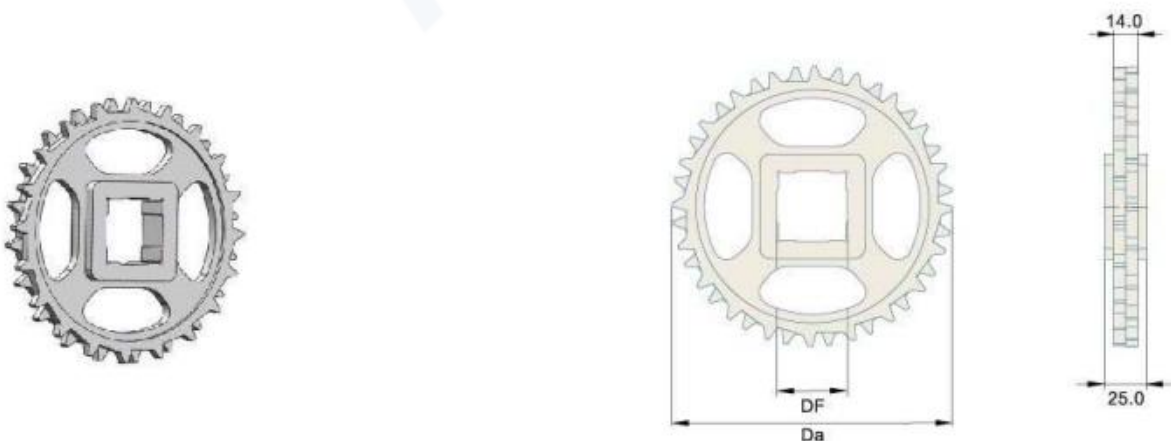

型号 Item Code	齿数 Teeth No.	外径 Da (mm)	方孔 Square Bore (mm)	圆孔 Round Bore (mm)
注塑链轮 Injection Sprocket				
Har2400-20T	20	163	30/40/50	30/40/50

Sprocket For Har2400/2401 Modular Belt

Har2400/2401型网链机加工链轮

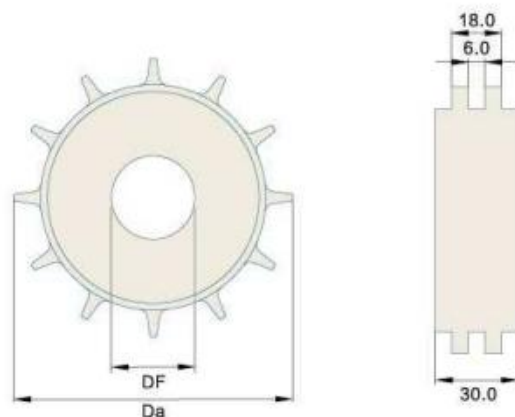

型号 Item Code	齿数 Teeth No.	外径 Da (mm)	方孔 Square Bore (mm)	圆孔 Round Bore (mm)
机加工链轮 Machined Sprocket				
Har2400/2401-9T	9	74	20/30	20/30
Har2400/2401-12T	12	100	20/30/40	20/30/40
Har2400/2401-16T	16	130	20/30/40	20/30/40
Har2400/2401-20T	20	163	20/30/40	20/30/40

备注：同时适用于Har2400平格网链、2401平格网链。

Sprocket For Har2480PMO Flexible Chains

Har2480PMO型柔性链机加工链轮

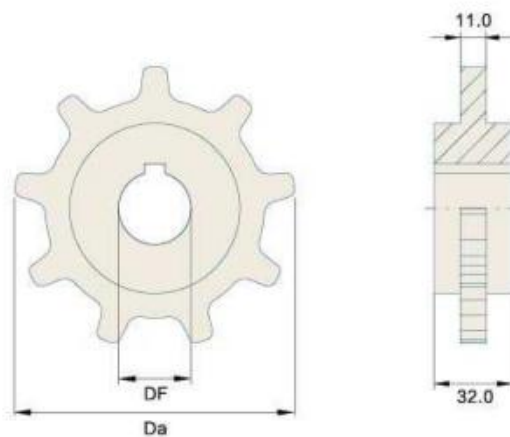

型号 Item Code	齿数 Teeth No.	外径 Da (mm)	方孔 Square Bore (mm)	圆孔 Round Bore (mm)
机加工链轮 Machined Sprocket				
Har2480PMO-9T	9	116.5	20-35	20-35
Har2480PMO-10T	10	128.5	25-40	25-40
Har2480PMO-11T	11	140.5	25-40	25-40
Har2480PMO-12T	12	152.5	25-40	25-40
Har2480PMO-13T	13	164.5	25-40	25-40

Sprocket For Har2501 Modular Belt

Har2501型机加工链轮

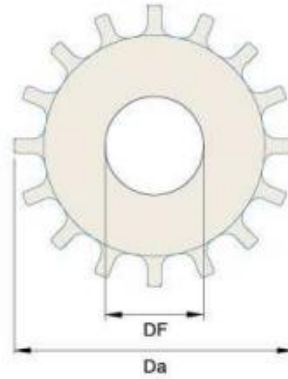

型号 Item Code	齿数 Teeth No.	外径 Da (mm)	方孔 Square Bore (mm)	圆孔 Round Bore (mm)
机加工链轮 Machined Sprocket				
Har2501-9T	9	74	20/30	20/30
Har2501-12T	12	99	20/30/40	20/30/40
Har2501-16T	16	127	20/30/40	20/30/40
Har2501-18T	18	143	20/30/40	20/30/40
Har2501-20T	20	163	20/30/40	20/30/40

Sprocket For Har2520 Modular Belt

Har2520型机加工链轮

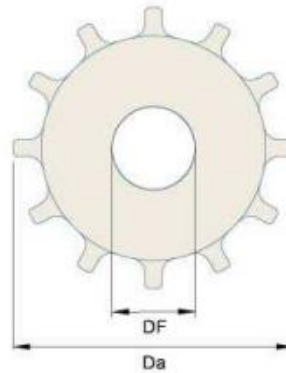

型号 Item Code	齿数 Teeth No.	外径 Da (mm)	方孔 Square Bore (mm)	圆孔 Round Bore (mm)
机加工链轮 Machined Sprocket				
Har2520-9T	9	73.2	20/30	20/30
Har2520-12T	12	99	20/30/40	20/30/40
Har2520-15T	15	125	20/30/40	20/30/40
Har2520-16T	16	133.5	20/30/40	20/30/40
Har2520-20T	20	163	20/30/40	20/30/40

Sprocket For Har2520 Modular Belt

Har2520型注塑链轮

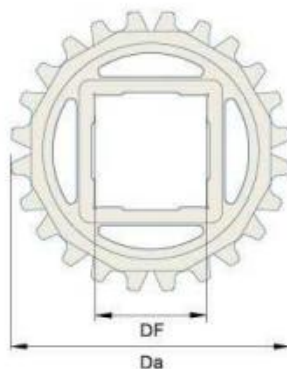
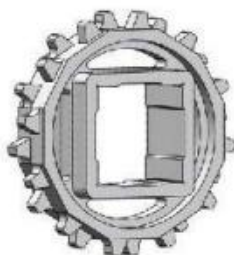

型号 Item Code	齿数 Teeth No.	外径 Da (mm)	方孔 Square Bore (mm)	圆孔 Round Bore (mm)
注塑链轮 Injection Sprocket				
Har2520-10T	10	85	40	30
Har2520-12T	12	99	40	30
Har2520-15T	15	124	40/50	30/40

Sprocket For Har2540 Modular Belt

Har2540型机加工链轮

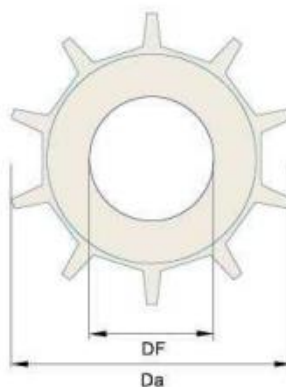

型号 Item Code	齿数 Teeth No.	外径 Da (mm)	方孔 Square Bore (mm)	圆孔 Round Bore (mm)
机加工链轮 Machined Sprocket				
Har2540-9T	9	74	20/30	20/30
Har2540-10T	10	83	20/30	20/30
Har2540-12T	12	99	20/30/40	20/30/40
Har2540-16T	16	130	20/30/40	20/30/40
Har2540-20T	20	163	20/30/40	20/30/40

Sprocket For Har2541 Modular Belt

Har2541型机加工链轮

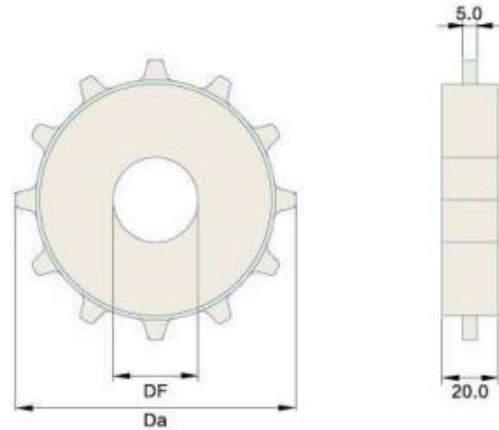

型号 Item Code	齿数 Teeth No.	外径 Da (mm)	方孔 Square Bore (mm)	圆孔 Round Bore (mm)
机加工链轮 Machined Sprocket				
Har2541-8T	8	70	25	20/25
Har2541-10T	10	82.5	25/30	25/30
Har2541-12T	12	99	25/40	20/25/30/40
Har2541-20T	20	169	25/40/60	25/30/40

Sprocket For Har2542 Modular Belt

Har2542型机加工链轮

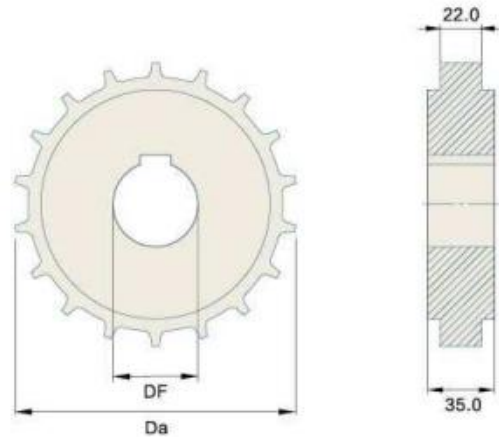

型号 Item Code	齿数 Teeth No.	外径 Da (mm)	方孔 Square Bore (mm)	圆孔 Round Bore (mm)
机加工链轮 Machined Sprocket				
Har2542-12T	12	98	30/40	25/30/35/40
Har2542-14T	14	114	30/40	25/30/35/40
Har2542-16T	16	130	30/40/60	25/30/35/40
Har2542-18T	18	148	30/40/60	25/30/35/40
Har2542-20T	20	162	30/40/60	25/30/35/40

Sprocket For Har2545 Modular Belt

Har2545型机加工链轮

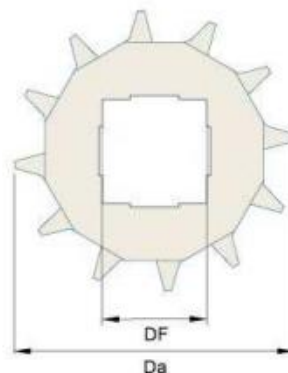

型号 Item Code	齿数 Teeth No.	外径 Da (mm)	方孔 Square Bore (mm)	圆孔 Round Bore (mm)
机加工链轮 Machined Sprocket				
Har2545-8T	8	78	25	20/25
Har2545-10T	10	108	25/40	20/25/30/40
Har2545-20T	20	173	25/40/60	20/30/40/50/60

Sprocket For Har2580 Flexible Chains

Har2580型柔性链机加工链轮

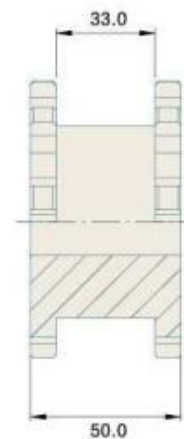
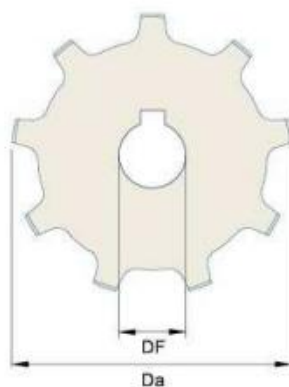

型号 Item Code	齿数 Teeth No.	外径 Da (mm)	方孔 Square Bore (mm)	圆孔 Round Bore (mm)
机加工链轮 Machined Sprocket				
Har2580-9T	9	103	20	20
Har2580-10T	10	135	20	20

Sprocket For Har2840 Flexible Chains

Har2840型柔性链机加工链轮

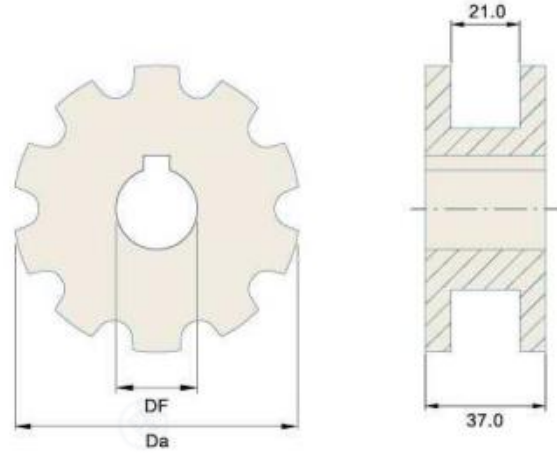

型号 Item Code	齿数 Teeth No.	外径 Da (mm)	方孔 Square Bore (mm)	圆孔 Round Bore (mm)
机加工链轮 Machined Sprocket				
Har2840-10T	10	88.6	—	25/35

Sprocket For Har3110 Modular Belt

Har3110型网链机加工链轮

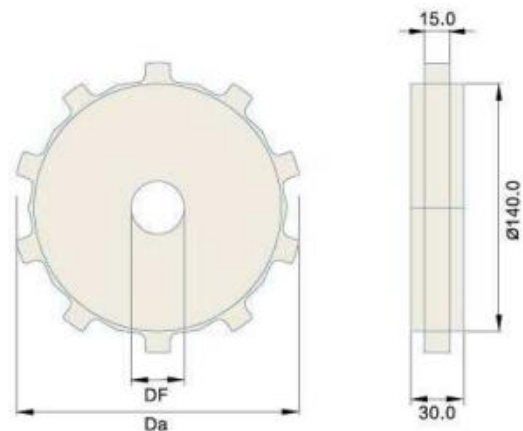

型号 Item Code	齿数 Teeth No.	外径 Da (mm)	方孔 Square Bore (mm)	圆孔 Round Bore (mm)
机加工链轮 Machined Sprocket				
Har3110-10T	10	164.4	30/40/60/90	30/40/60/90
Har3110-12T	12	196	30/40/60/90	30/40/60/90

Sprocket For Har4809 Modular Belt

Har4809型网链注塑链轮

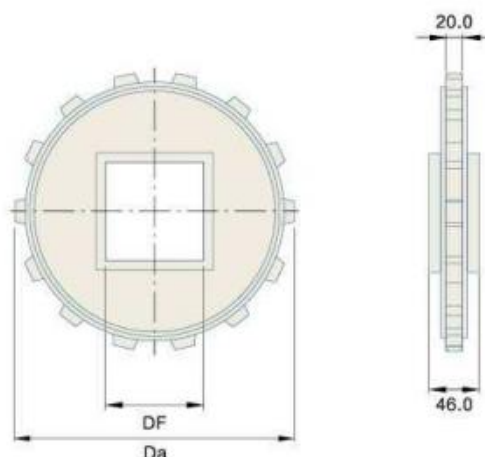

型号 Item Code	齿数 Teeth No.	外径 Da (mm)	方孔 Square Bore (mm)	圆孔 Round Bore (mm)
注塑链轮 Injection Sprocket				
Har4809-7T	7	126	30/40/50	30/40/50
Har4809-9T	9	164	30/40/50/60	30/40/50/60
Har4809-12T	12	221	30/40/50/60	30/40/50/60
Har4809-14T	14	257	30/40/50/60	30/40/50/60
Har4809-17T	17	314	30/40/50/60/90	30/40/50/60/90

Sprocket For Har5935 Modular Belt

Har5935型机加工链轮

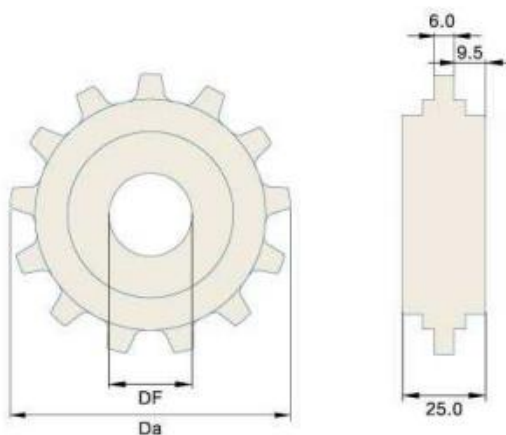

型号 Item Code	齿数 Teeth No.	外径 Da (mm)	方孔 Square Bore (mm)	圆孔 Round Bore (mm)
机加工链轮 Machined Sprocket				
Har5935-10T	10	62	20/25	20/25
Har5935-13T	13	79.6	20/25/30	20/25/30
Har5935-18T	18	109.7	25/30/35/40/50	25/30/35/40/50
Har5935-20T	20	121.8	25/30/40/50/60	25/30/40/50/60
Har5935-24T	24	147	30/40/50/60/65	30/40/50/60/65
Har5935-31T	31	188.3	30/40/50/60/70	30/40/50/60/70

Sprocket For Har5966 Modular Belt

Har5966型网链机加工链轮

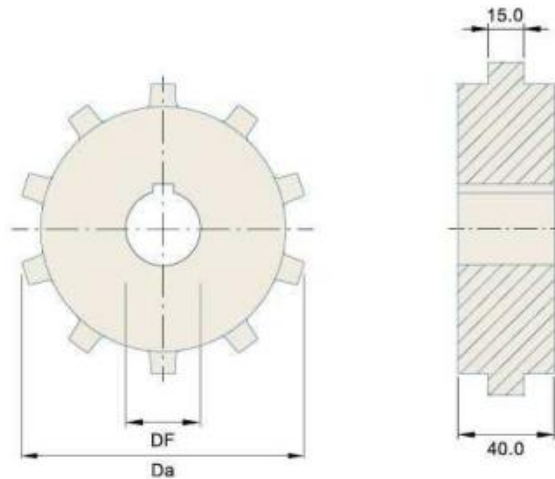

型号 Item Code	齿数 Teeth No.	外径 Da (mm)	方孔 Square Bore (mm)	圆孔 Round Bore (mm)
机加工链轮 Machined Sprocket				
Har5966-9T	9	115	20/30	20/30
Har5966-12T	12	145.6	30/40/50	30/40/50
Har5966-16T	16	194.1	30/40/50	30/40/50
Har5966-20T	20	242.6	30/40/50/60	30/40/50/60

Sprocket For Har5997 Modular Belt

Har5997型网链注塑链轮

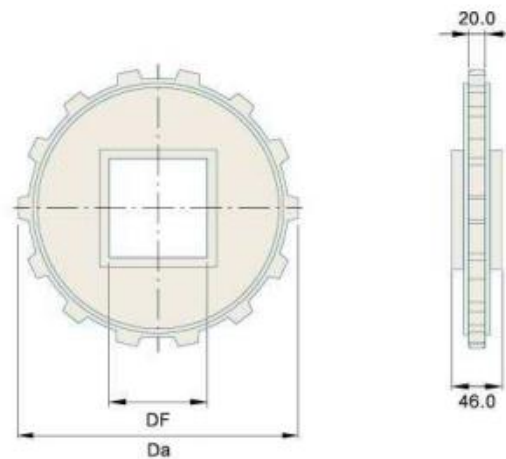

型号 Item Code	齿数 Teeth No.	外径 Da (mm)	方孔 Square Bore (mm)	圆孔 Round Bore (mm)
注塑链轮 Injection Sprocket				
Har5997-7T	7	126	40/50	40/50
Har5997-9T	9	164	40/50/60	40/50/60
Har5997-12T	12	221	40/50/60	40/50/60
Har5997-14T	14	257	40/50/60/90	40/50/60/90
Har5997-17T	17	314	40/50/60/90	40/50/60/90

Sprocket For Har6100 Modular Belt

Har6100型网链机加工链轮

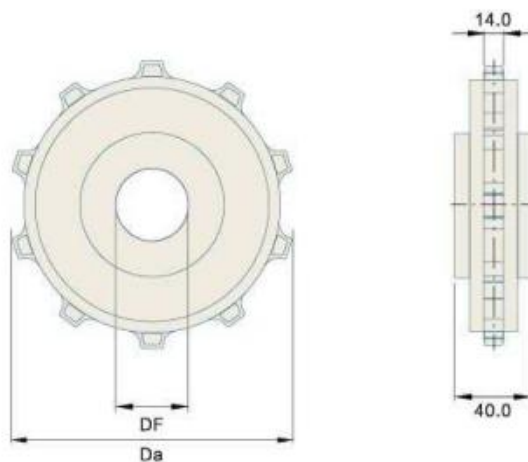

型号 Item Code	齿数 Teeth No.	外径 Da (mm)	方孔 Square Bore (mm)	圆孔 Round Bore (mm)
机加工链轮 Machined Sprocket				
Har6100-8T	8	131.5	25/30/40	25/30/40
Har6100-10T	10	162	25/30/40/50	25/30/40/50
Har6100-12T	12	195	25/30/40/50	25/30/40/50
Har6100-14T	14	228	25/30/40/50	25/30/40/50
Har6100-16T	16	259	25/30/40/50	25/30/40/50

Sprocket For Har6100 Modular Belt

Har6100型注塑链轮

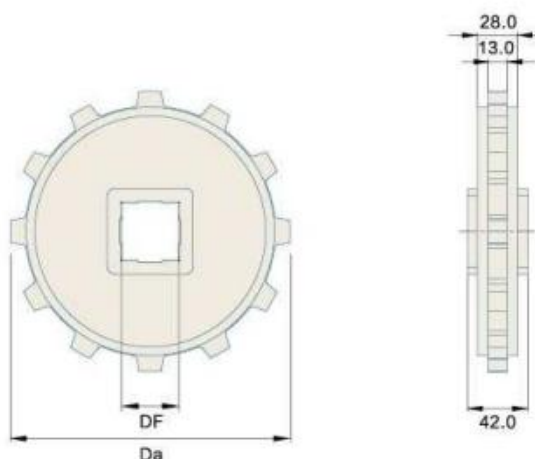
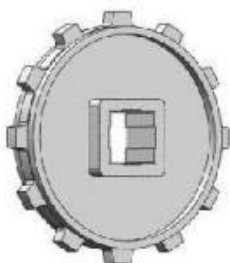

型号 Item Code	齿数 Teeth No.	外径 Da (mm)	方孔 Square Bore (mm)	圆孔 Round Bore (mm)
注塑链轮 Injection Sprocket				
Har6100-12T	12	195	50	—

Sprocket For Har6200NP Modular Belt

Har6200NP型机加工链轮 中间

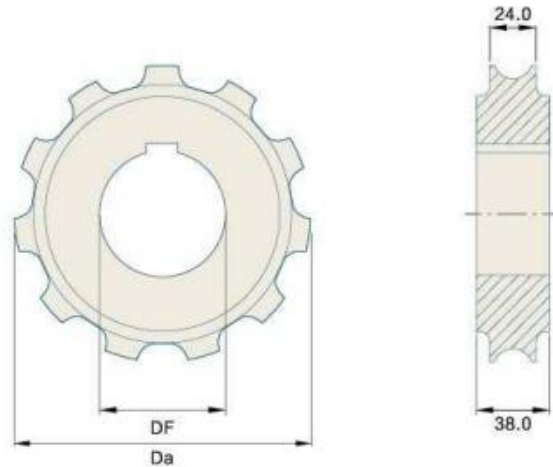

型号 Item Code	齿数 Teeth No.	外径 Da (mm)	方孔 Square Bore (mm)	圆孔 Round Bore (mm)
机加工链轮 Machined Sprocket				
Har6200NP-8T	8	112.1	25/35	25/35/45
Har6200NP-10T	10	140.1	35/45/50	35/45/50
Har6200NP-12T	12	168.1	35/45/50	35/45/50
Har6200NP-16T	16	224	35/45/50	35/45/50

Sprocket For Har6200NP Modular Belt

Har6200NP型机加工链轮 两边

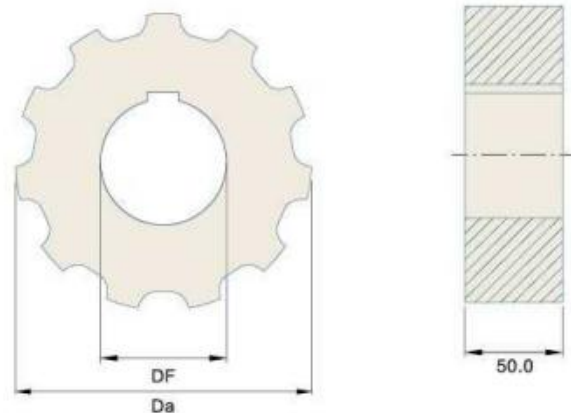

型号 Item Code	齿数 Teeth No.	外径 Da (mm)	方孔 Square Bore (mm)	圆孔 Round Bore (mm)
机加工链轮 Machined Sprocket				
Har6200NP-8T	8	112.1	25/35	25/35/45
Har6200NP-10T	10	140.1	35/45/50	35/45/50
Har6200NP-12T	12	168.1	35/45/50	35/45/50
Har6200NP-16T	16	224	35/45/50	35/45/50

Sprocket For Har7100 Modular Belt

Har7100型网链机加工链轮

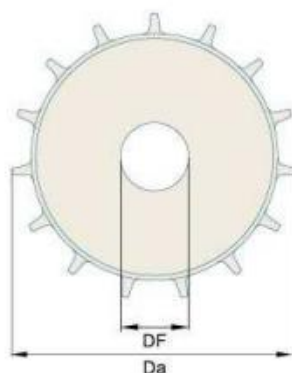

型号 Item Code	齿数 Teeth No.	外径 Da (mm)	方孔 Square Bore (mm)	圆孔 Round Bore (mm)
机加工链轮 Machined Sprocket				
Har7100-12T	12	97	20/30	20/30/35/40
Har7100-13T	13	105	20/30/35/40	20/30/35/40
Har7100-15T	15	126	20/30/35/40	20/30/35/40
Har7100-18T	18	144.5	20/30/35/40	20/30/35/40
Har7100-28T	28	229.4	20/30/35/40	20/30/35/40

Sprocket For Har7120 Modular Belt

Har7120型网链机加工链轮



型号 Item Code	齿数 Teeth No.	外径 Da (mm)	方孔 Square Bore (mm)	圆孔 Round Bore (mm)
机加工链轮 Machined Sprocket				
Har7120-15T	15	61.6	—	20/30
Har7120-17T	17	70.2	25	20/25
Har7120-24T	24	98.8	25/30/35	25/30/35
Har7120-36T	36	147	30/40	30/40
Har7120-38T	38	153.7	30/40	30/40

Sprocket For Har7300 Modular Belt

Har7300型网链机加工链轮

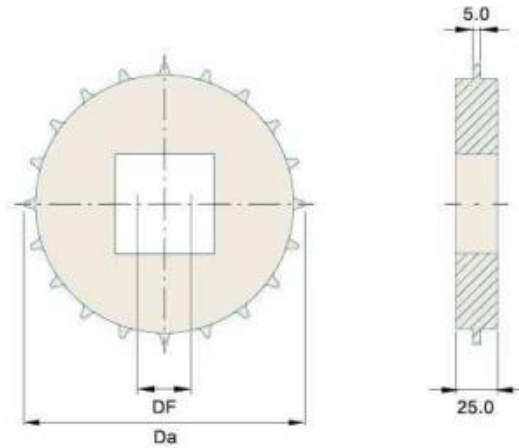

型号 Item Code	齿数 Teeth No.	外径 Da (mm)	方孔 Square Bore (mm)	圆孔 Round Bore (mm)
机加工链轮 Machined Sprocket				
Har7300-8T	8	68	—	20/25
Har7300-12T	12	104.5	25/30/40/50	25/30/40/50
Har7300-15T	15	130	25/30/40/50	25/30/40/50
Har7300-18T	18	154	25/30/40/50	25/30/40/50
Har7300-20T	20	167	25/30/40/50	25/30/40/50

Sprocket For Har7400 Modular Belt

Har7400型网链机加工链轮

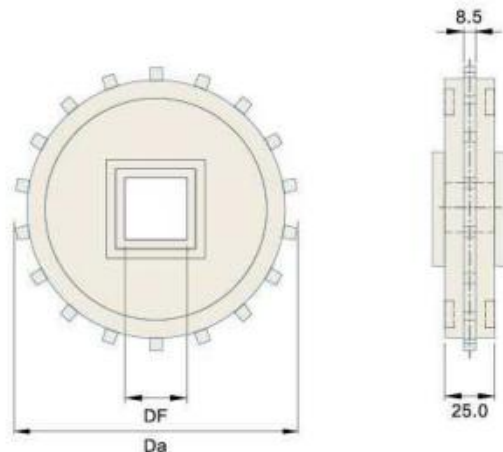

型号 Item Code	齿数 Teeth No.	外径 Da (mm)	方孔 Square Bore (mm)	圆孔 Round Bore (mm)
机加工链轮 Machined Sprocket				
Har7400-12T	12	53.5	—	25
Har7400-18T	18	77.6	30/40	30/40
Har7400-19T	19	81.6	30/40	30/40
Har7400-20T	20	85.6	30/40	30/40

Sprocket For Har7500 Modular Belt

Har7500型网链注塑链轮

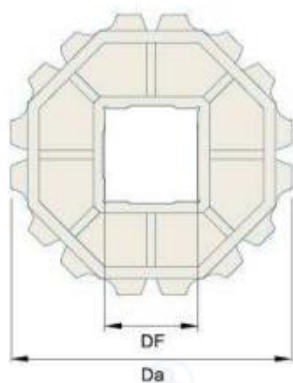

型号 Item Code	齿数 Teeth No.	外径 Da (mm)	方孔 Square Bore (mm)	圆孔 Round Bore (mm)
注塑链轮 Injection Sprocket				
Har7500-8T	8	122.7	40	30

Sprocket For Har7705 Modular Belt

Har7705型网链机加工链轮

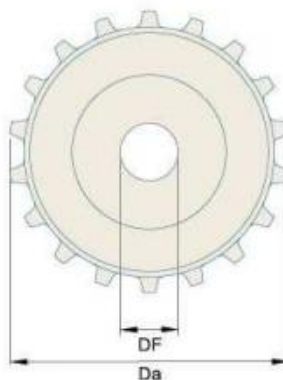

型号 Item Code	齿数 Teeth No.	外径 Da (mm)	方孔 Square Bore (mm)	圆孔 Round Bore (mm)
机加工链轮 Machined Sprocket				
Har7705-16T	16	130.6	25/30/35/40	25/30/35/40
Har7705-18T	18	146	25/30/35/40	25/30/35/40

Sprocket For Har7800 Modular Belt

Har7800型网链机加工链轮

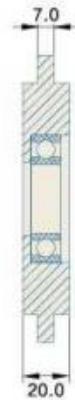
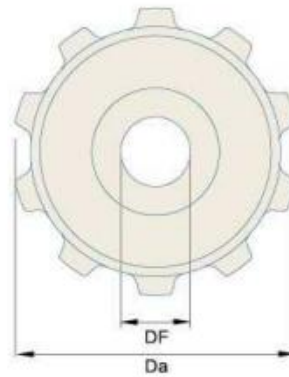

型号 Item Code	齿数 Teeth No.	外径 Da (mm)	方孔 Square Bore (mm)	圆孔 Round Bore (mm)
机加工链轮 Machined Sprocket				
Har7800-10T	10	124	20/30/40	20/30/40
Har7800-13T	13	136	20/30/40	20/30/40

Sprocket For Har7900 Modular Belt

Har7900型网链机加工链轮

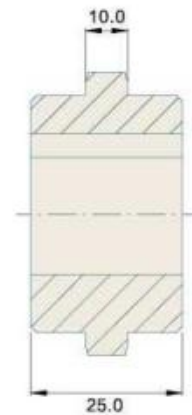
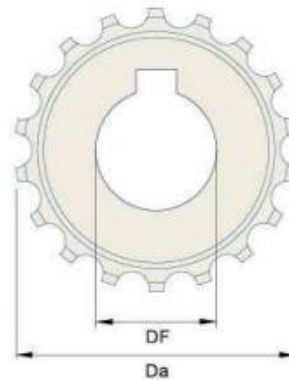

型号 Item Code	齿数 Teeth No.	外径 Da (mm)	方孔 Square Bore (mm)	圆孔 Round Bore (mm)
机加工链轮 Machined Sprocket				
Har7900-18T	18	47	—	20/25
Har7900-20T	20	52.2	—	20/25
Har7900-24T	24	62	20/25/30/40	20/25/30/40
Har7900-36T	36	92	20/25/30/40	20/25/30/40

备注：材料普通尼龙。

Sprocket For Har7910 Modular Belt

Har7910型网链机加工链轮

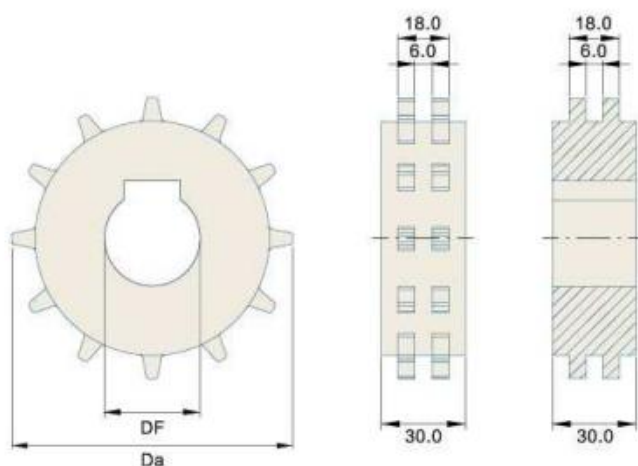

型号 Item Code	齿数 Teeth No.	外径 Da (mm)	方孔 Square Bore (mm)	圆孔 Round Bore (mm)
机加工链轮 Machined Sprocket				
Har7910-12T	12	100	30/40	30/40
Har7910-14T	14	114.5	30/40	30/40
Har7910-16T	16	132.5	30/40	30/40

Sprocket For Har7920 Modular Belt

Har7920型网链机加工链轮

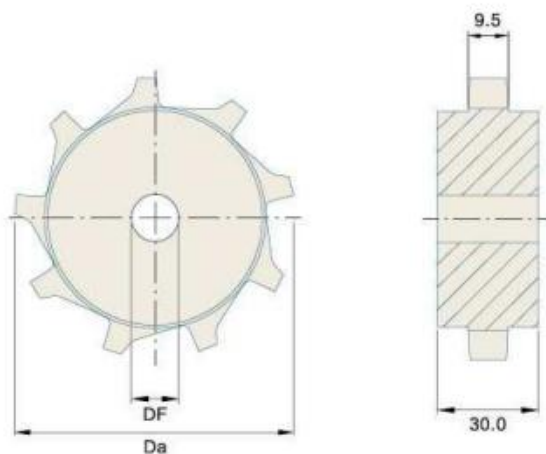

型号 Item Code	齿数 Teeth No.	外径 Da (mm)	方孔 Square Bore (mm)	圆孔 Round Bore (mm)
机加工链轮 Machined Sprocket				
Har7920-11T	11	99	30/40	30/40
Har7920-15T	15	134.5	30/40	30/40
Har7920-17T	17	153	30/40	30/40

Sprocket For Har7930 Modular Belt

Har7930型网链机加工链轮

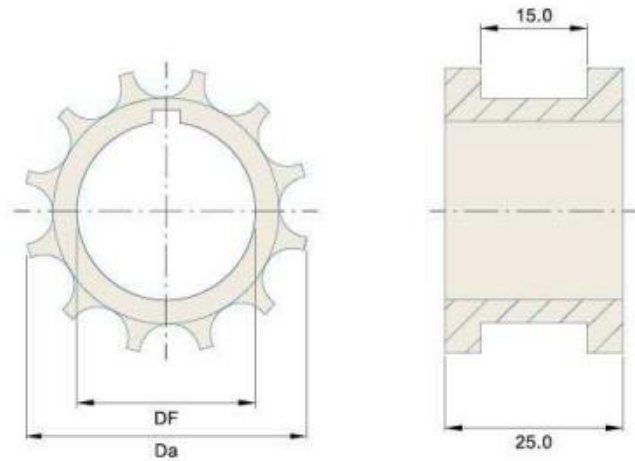

型号 Item Code	齿数 Teeth No.	外径 Da (mm)	方孔 Square Bore (mm)	圆孔 Round Bore (mm)
机加工链轮 Machined Sprocket				
Har7930-16T	16	53	—	20/25
Har7930-18T	18	59	—	20/25
Har7930-20T	20	65	—	20/25

Sprocket For Har7940 Modular Belt

Har7940型网链机加工链轮

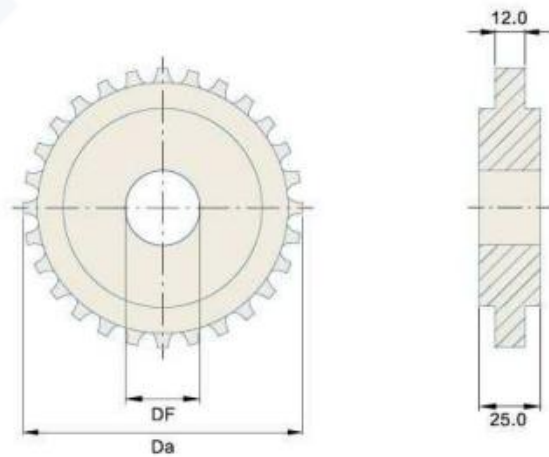

型号 Item Code	齿数 Teeth No.	外径 Da (mm)	方孔 Square Bore (mm)	圆孔 Round Bore (mm)
机加工链轮 Machined Sprocket				
Har7940-12T	12	49.8	—	20/25
Har7940-17T	17	70.2	25	25/30/40
Har7940-24T	24	98.8	25/40	30/40/50
Har7940-28T	28	113.2	25/40	40/50/60
Har7940-36T	36	148	25/40	40/50/60

Sprocket For Har7950 Modular Belt

Har7950型网链机加工链轮

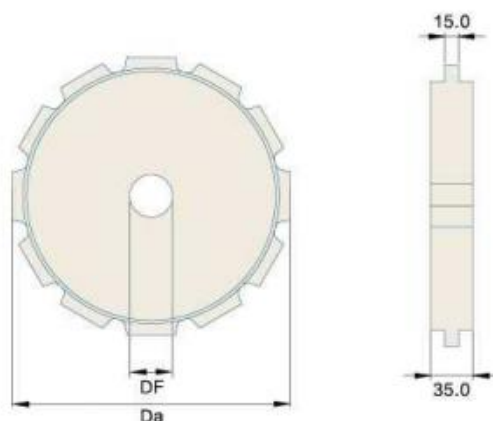

型号 Item Code	齿数 Teeth No.	外径 Da (mm)	方孔 Square Bore (mm)	圆孔 Round Bore (mm)
机加工链轮 Machined Sprocket				
Har7950-12T	12	198.5	40/50/60	40/50/60

Sprocket For Har7960 Modular Belt

Har7960型网链机加工链轮

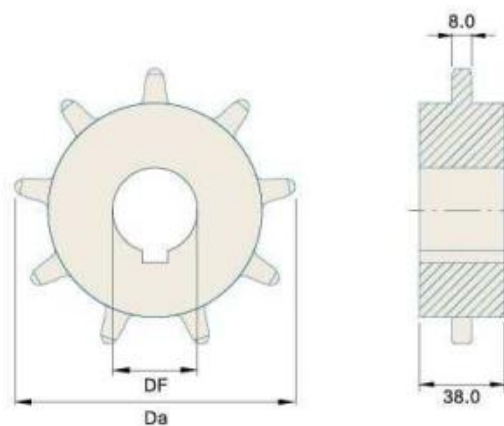
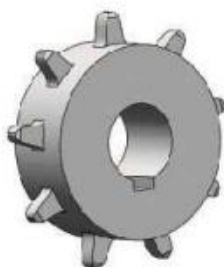

型号 Item Code	齿数 Teeth No.	外径 Da (mm)	方孔 Square Bore (mm)	圆孔 Round Bore (mm)
机加工链轮 Machined Sprocket				
Har7960-8T	8	102	20/25/30/40	20/25/30/40
Har7960-9T	9	115	25/30/40	25/30/40
Har7960-10T	10	128	25/30/40/50	25/30/40/50
Har7960-12T	12	152	30/40/50/60	30/40/50/60

Sprocket For Har8200 Modular Belt

Har8200型网链机加工链轮

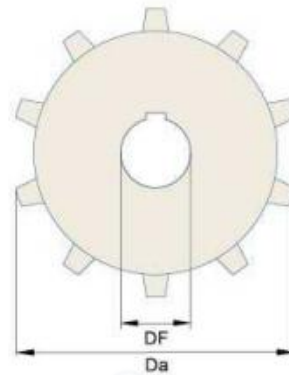

型号 Item Code	齿数 Teeth No.	外径 Da (mm)	方孔 Square Bore (mm)	圆孔 Round Bore (mm)
机加工链轮 Machined Sprocket				
Har8200-10T	10	170.66	40/50/60	40/50/60

Sprocket For Har8505 Modular Belt

Har8505型网链机加工链轮

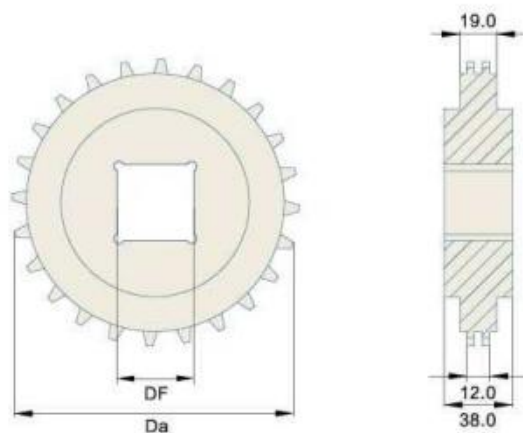
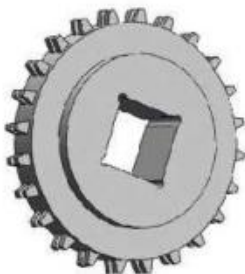

型号 Item Code	齿数 Teeth No.	外径 Da (mm)	方孔 Square Bore (mm)	圆孔 Round Bore (mm)
注塑链轮 Injection Sprocket				
Har8505-17T	17	105	25-35	25-35

Sprocket For Har8505 Modular Belt

Har8505型注塑链轮 25齿

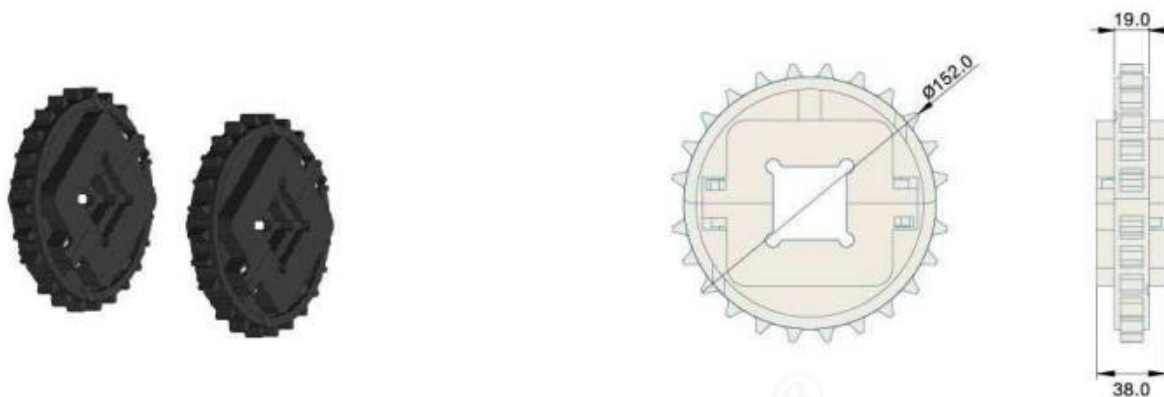

型号 Item Code	齿数 Teeth No.	外径 Da (mm)	方孔 Square Bore (mm)	圆孔 Round Bore (mm)
注塑链轮 Injection Sprocket				
Har8505-25T	25	152	40	—

Sprocket For Har8600 Modular Belt

Har8600型网链机加工链轮

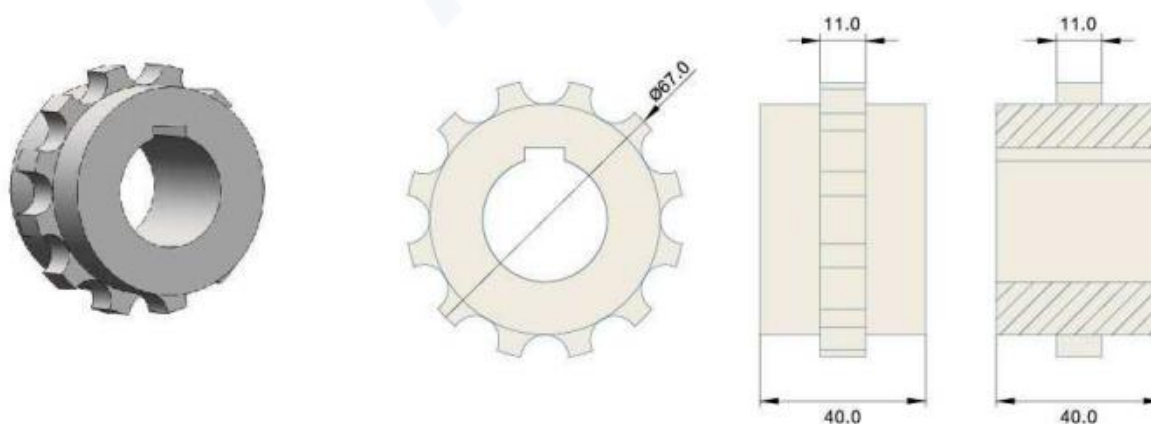

型号 Item Code	齿数 Teeth No.	外径 Da (mm)	方孔 Square Bore (mm)	圆孔 Round Bore (mm)
机加工链轮 Machined Sprocket				
Har8600-12T	12	67	—	30

Sprocket For Har8600 Modular Belt

Har8600型网链机加工链轮

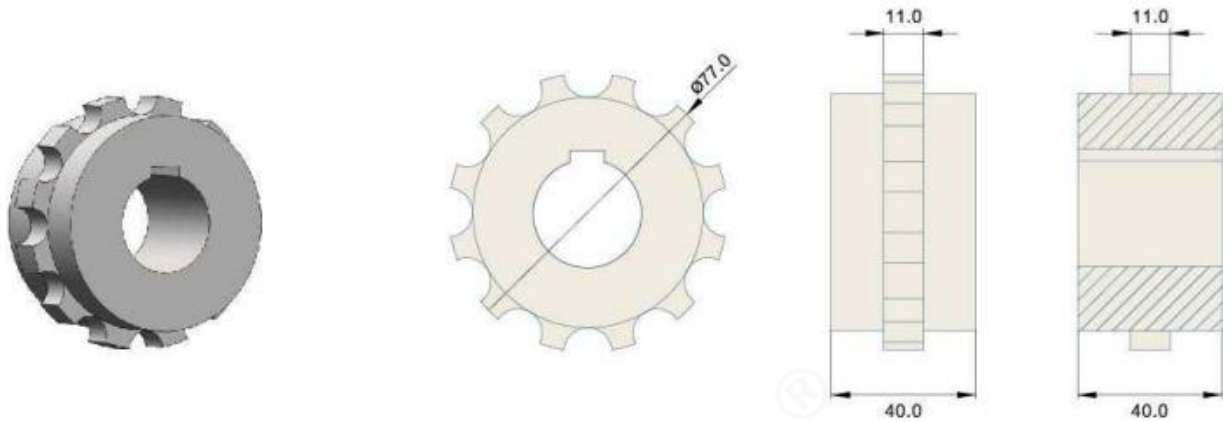

型号 Item Code	齿数 Teeth No.	外径 Da (mm)	方孔 Square Bore (mm)	圆孔 Round Bore (mm)
机加工链轮 Machined Sprocket				
Har8600-12T	12	77	—	30

Sprocket For Har8600 Modular Belt

Har8600型网链机加工链轮

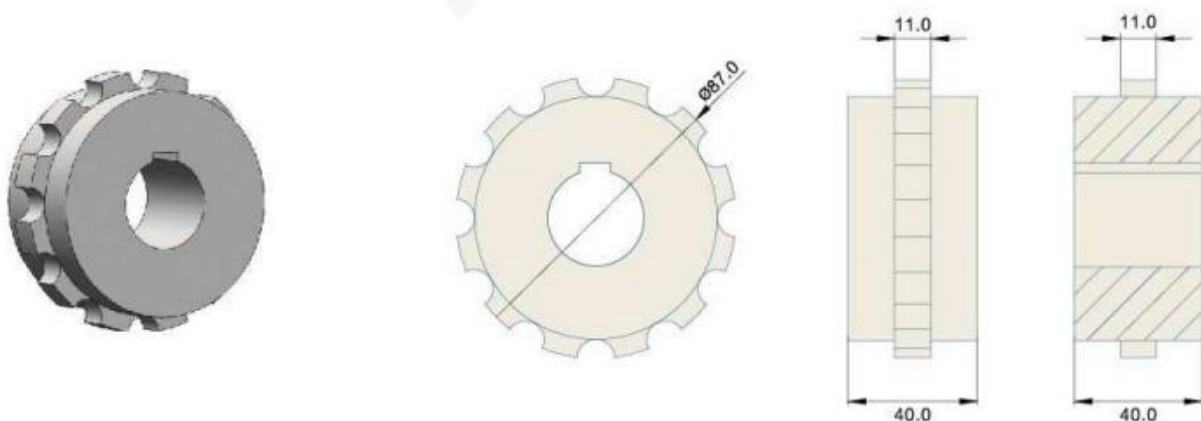

型号 Item Code	齿数 Teeth No.	外径 Da (mm)	方孔 Square Bore (mm)	圆孔 Round Bore (mm)
机加工链轮 Machined Sprocket				
Har8600-12T	12	87	—	30

Sprocket For Har8600 Modular Belt

Har8600型网链机加工链轮

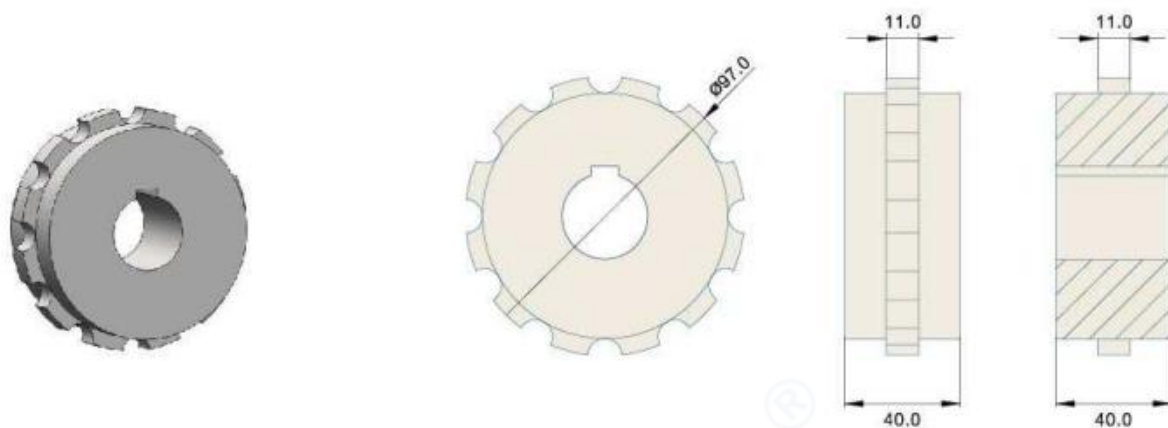

型号 Item Code	齿数 Teeth No.	外径 Da (mm)	方孔 Square Bore (mm)	圆孔 Round Bore (mm)
机加工链轮 Machined Sprocket				
Har8600-12T	12	97	—	30

Sprocket For Har8600 Modular Belt

Har8600型网链机加工链轮

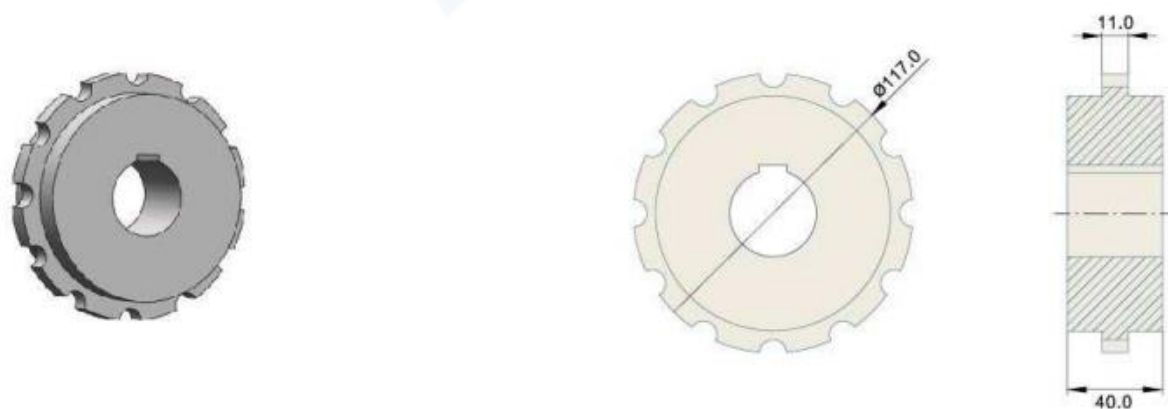

型号 Item Code	齿数 Teeth No.	外径 Da (mm)	方孔 Square Bore (mm)	圆孔 Round Bore (mm)
机加工链轮 Machined Sprocket				
Har8600-12T	12	117	—	30

Sprocket For Har8825 Modular Belt

Har8825型链板机加工链轮

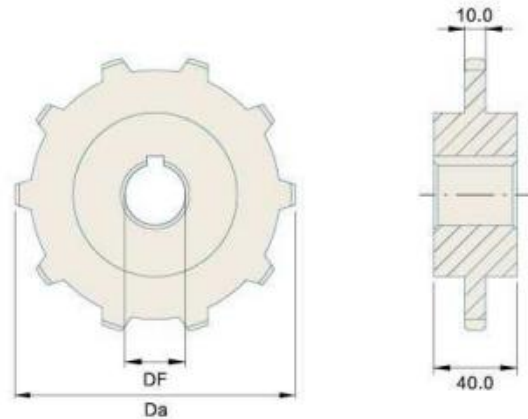

型号 Item Code	齿数 Teeth No.	外径 Da (mm)	方孔 Square Bore (mm)	圆孔 Round Bore (mm)
机加工链轮 Machined Sprocket				
Har8825-10T	10	135.27	40	25-50
Har8825-11T	11	143.27	40	25-50
Har8825-12T	12	152.27	40	25-50

Sprocket For Har042680 Flexible Chains

Har042680型柔性链机加工链轮

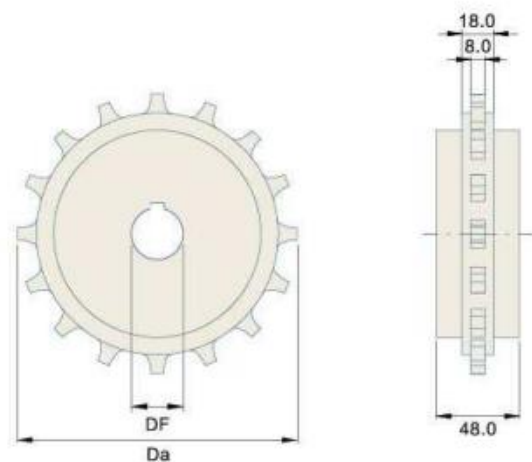

型号 Item Code	齿数 Teeth No.	外径 Da (mm)	方孔 Square Bore (mm)	圆孔 Round Bore (mm)
机加工链轮 Machined Sprocket				
Har042680-16T	16	163	30	30

Sprocket For Har216628 Flexible Chains

Har216628型柔性链机加工链轮

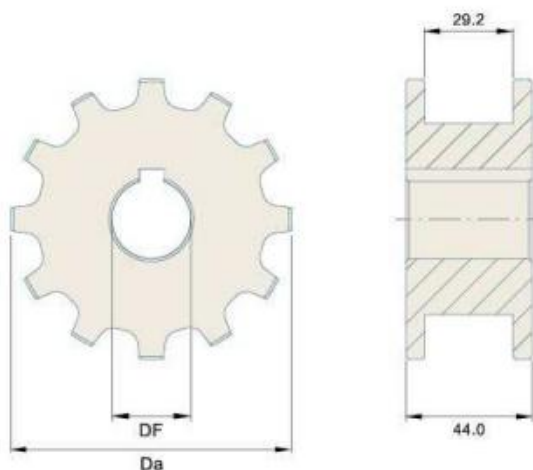

型号 Item Code	齿数 Teeth No.	外径 Da (mm)	方孔 Square Bore (mm)	圆孔 Round Bore (mm)
机加工链轮 Machined Sprocket				
Har216628-8T	8	72.2	20-30	20-30
Har216628-9T	9	80.5	20-30	20-30
Har216628-10T	10	88.5	20-30	20-30
Har216628-11T	11	97.0	20-40	20-40
Har216628-13T	13	112.5	20-40	20-40
Har216628-14T	14	117.2	20-40	20-40
Har216628-15T	15	128.5	20-40	20-40

Sprocket For HarPT280 Flexible Chains

HarPT280型柔性链机加工链轮

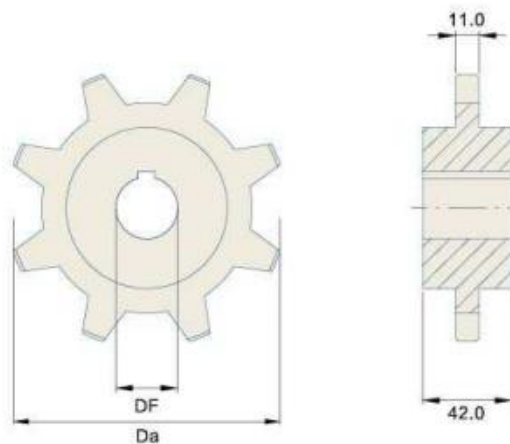

型号 Item Code	齿数 Teeth No.	外径 Da (mm)	方孔 Square Bore (mm)	圆孔 Round Bore (mm)
机加工链轮 Machined Sprocket				
HarPT280-10T	10	165.1	30/40	30/40
HarPT280-12T	12	197.1	30/40	30/40

Sprocket For HarQNB Modular Belt

HarQNB型机加工链轮

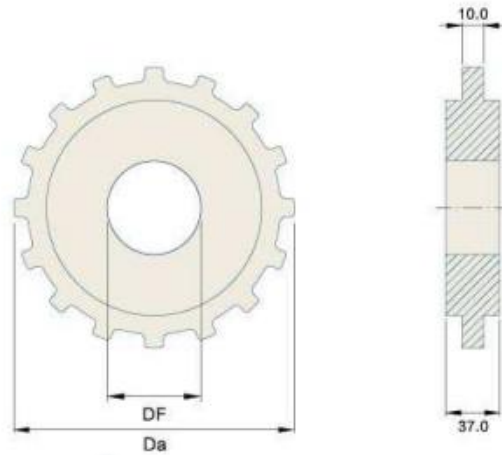

型号 Item Code	齿数 Teeth No.	外径 Da (mm)	方孔 Square Bore (mm)	圆孔 Round Bore (mm)
机加工链轮 Machined Sprocket				
HarQNB-10T	10	81	40/50	40/50
HarQNB-12T	12	97	40/50	40/50
HarQNB-15T	15	121	50/60	50/60
HarQNB-18T	18	146.3	50/60	50/60

Sprocket For HarQNB Modular Belt

HarQNB型注塑链轮 分半

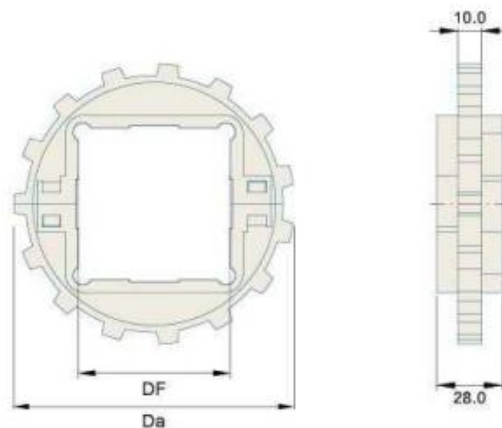
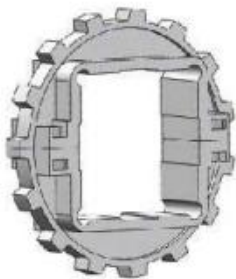

型号 Item Code	齿数 Teeth No.	外径 Da (mm)	方孔 Square Bore (mm)	圆孔 Round Bore (mm)
注塑链轮 Injection Sprocket				
HarQNB-15T	15	121	65	—

Sprocket For HarQNC Modular Belt

HarQNC型网链机加工链轮

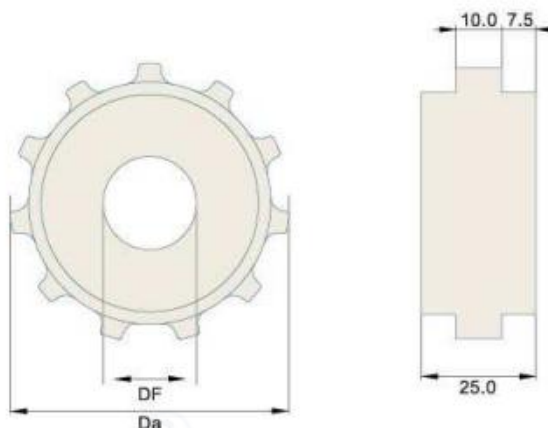

型号 Item Code	齿数 Teeth No.	外径 Da (mm)	方孔 Square Bore (mm)	圆孔 Round Bore (mm)
机加工链轮 Machined Sprocket				
HarQNC-11T	11	90	25/30/40	25/30/40
HarQNC-16T	16	130	25/30/40	25/30/40

Sprocket For HarRT114 Top Chains

HarRT114型链板机加工链轮

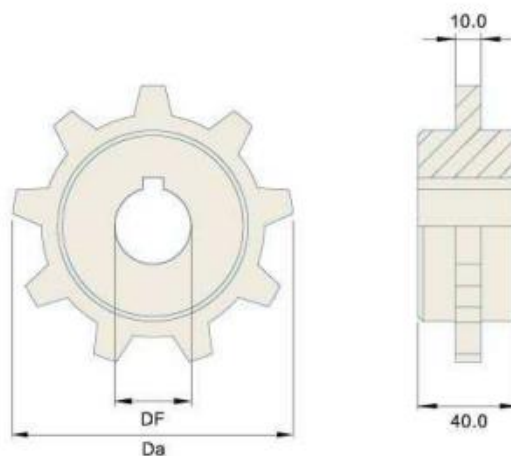

型号 Item Code	齿数 Teeth No.	外径 Da (mm)	方孔 Square Bore (mm)	圆孔 Round Bore (mm)
机加工链轮 Machined Sprocket				
HarRT114-9T	9	111	25/30/40	25/30/40
HarRT114-10T	10	123	25/30/40	25/30/40
HarRT114-11T	11	135.2	25/30/40	25/30/40
HarRT114-12T	12	146	25/30/40	25/30/40

链轮对准

- 在相同位置对准链轮齿。沿轴进行检查。
- 确保在轴的同侧对准齿数为奇数的所有链轮上的定位孔。

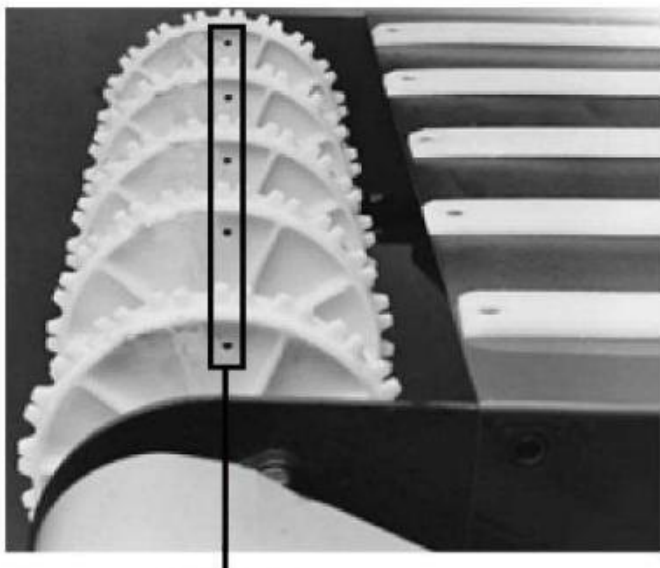

所有定位孔已对准

- 在方轴上安装齿数除以4后商为奇数的链轮时，确保在轴的同侧对准链轮对准槽。

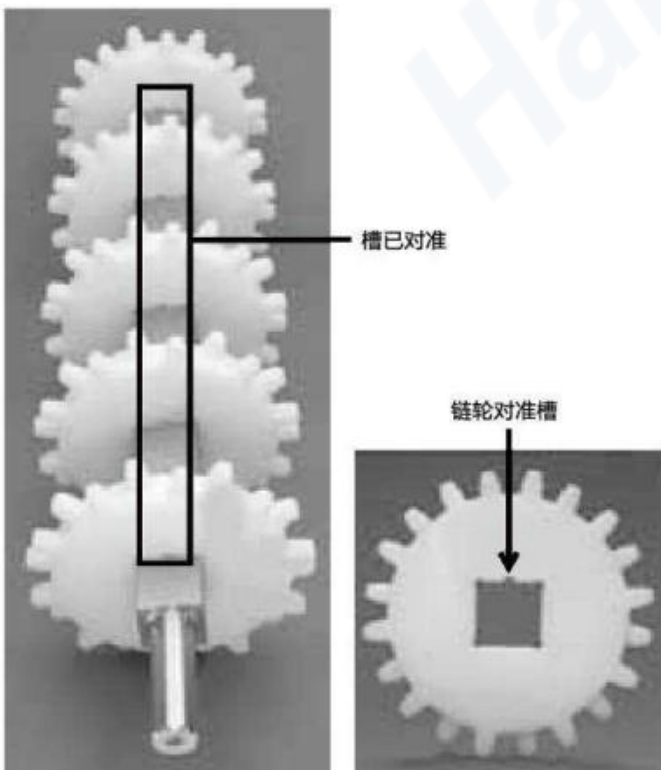

链轮在轴上的位置

- 将一个链轮分别固定在驱动轴和从动轴上，以保持正确的侧向导向定位。

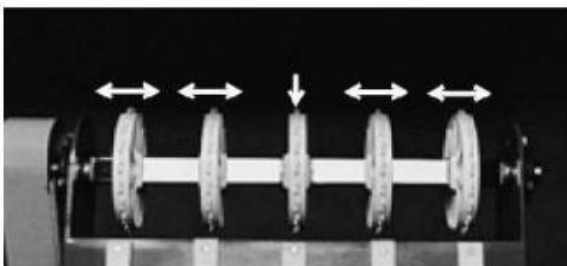

A-固定链轮

- 将固定链轮置于每个轴上的相同位置。
- 确保轴上的非固定链轮可以随着传送带的伸长和缩短自由移动。
- 如果每个轴上只有两个链轮，则只固定驱动轴颈侧的链轮。
- 有关中心链轮偏移量和最大链轮间距的信息，请参见以下图表。

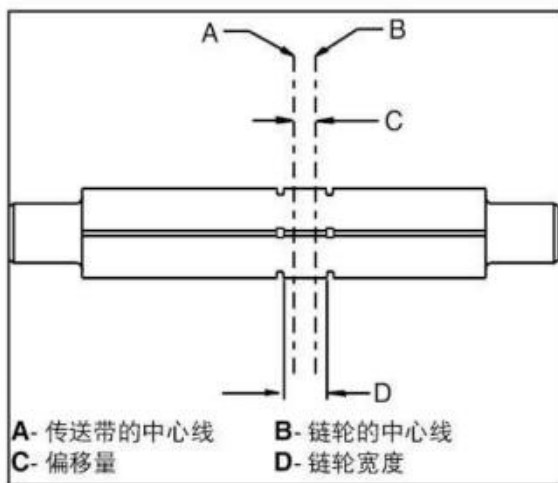

HarH601 Series Rails

HarH601型护栏

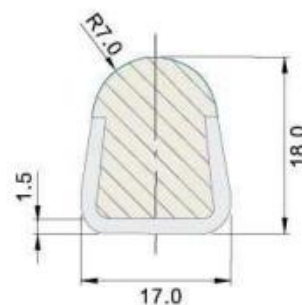

型号 Type	材质 Material	颜色 Color	重量 Weight (KG/M)
HarH601	PE+SUS	White	0.6

Remark: this type product is 3m/PC.

HarH602 Series Rails

HarH602型护栏

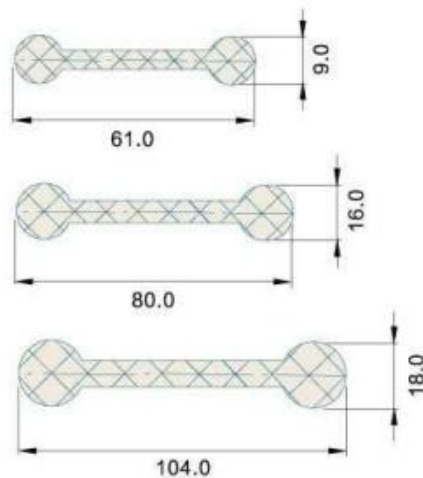

型号 Type	材质 Material	颜色 Color	重量 Weight (KG/M)
HarH602	PE	Black	0.14

Remark: this type product is 3m/PC.

HarH603 Series Rails

HarH603型护栏

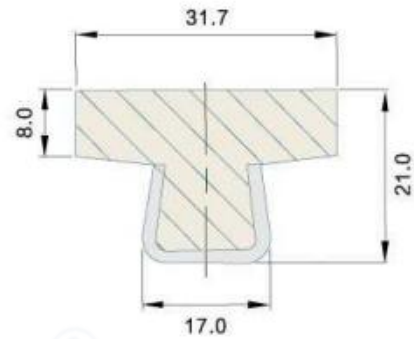

型号 Type	材质 Material	颜色 Color	重量 Weight (KG/M)
HarH603	PE+SUS	White	0.72

HarH604 Series Rails

HarH604型护栏

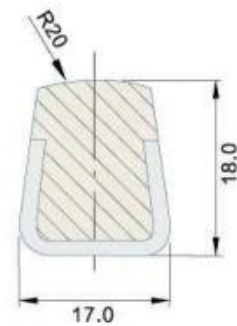

型号 Type	材质 Material	颜色 Color	重量 Weight (KG/M)
HarH604	PE+SUS	White	0.45

Remark: this type product is 3m/PC.

HarH605 Series Guide Rails

HarH605型大C护栏

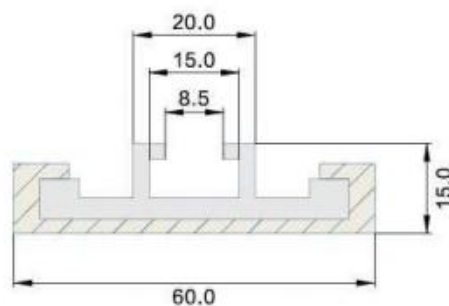
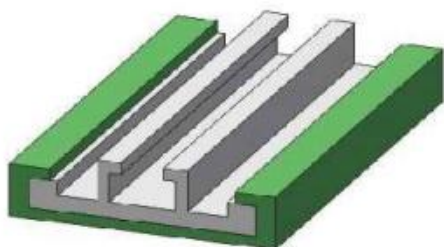

型号 Type	材质 Material	颜色 Color	重量 Weight (KG/M)
HarH605	PE+Aluminum	Green	0.89

Remark: this type product is 3m/PC.

HarH606 Series Rails

HarH606型护栏

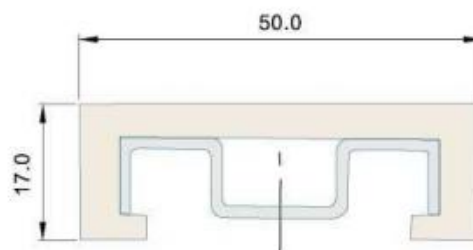

型号 Type	材质 Material	颜色 Color	重量 Weight (KG/M)
HarH606	PE+SUS	Black	0.8

Remark: this type product is 3m/PC.

HarH607 Series Rails

HarH607型护栏

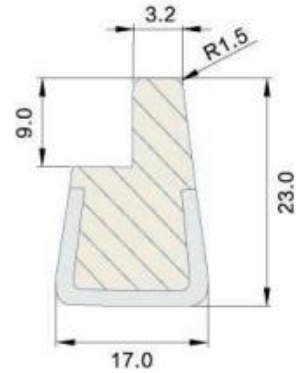

型号 Type	材质 Material	颜色 Color	重量 Weight (KG/M)
HarH607	PE+SUS	Green	0.62

Remark: this type product is 3m/PC.

HarH608 Series Guide Rails

HarH608型小C护栏

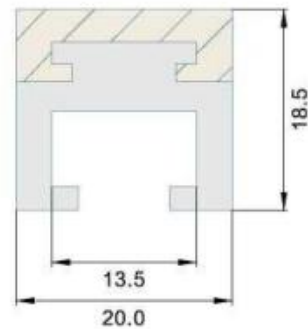
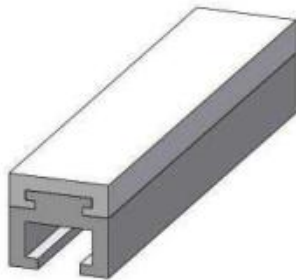

型号 Type	材质 Material	颜色 Color	重量 Weight (KG/M)
HarH608	PE+Aluminum	Green/White	0.5

Remark: this type product is 3m/PC.

HarH609 Series Guide Rails

HarH609型小C护栏

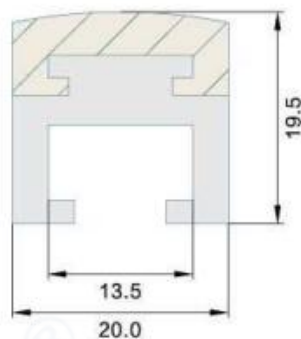
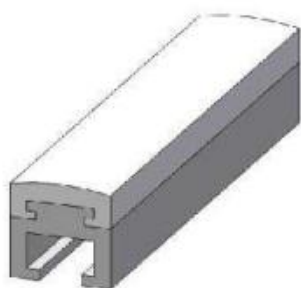

型号 Type	材质 Material	颜色 Color	重量 Weight (KG/M)
HarH609	PE+Aluminum	Green/White	0.65

Remark: this type product is 3m/PC.

HarH610 Series Guide Rails

HarH610型小C护栏

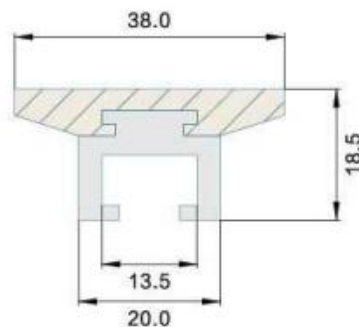
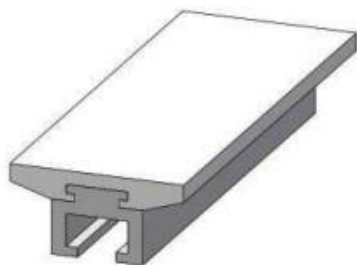

型号 Type	材质 Material	颜色 Color	重量 Weight (KG/M)
HarH610	PE+Aluminum	Green/White	0.55

Remark: this type product is 3m/PC.

HarH611 Series Guide Rails

HarH611型 C护栏

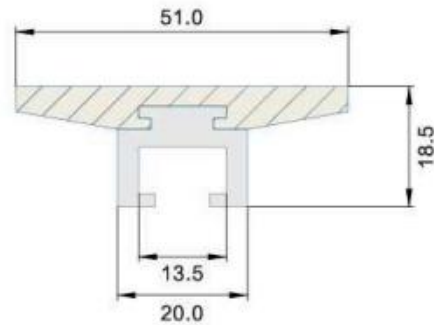
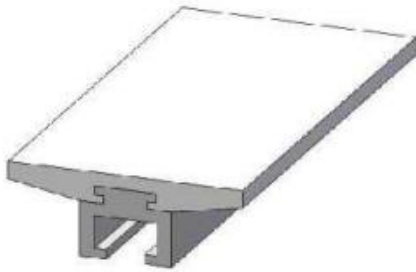

型号 Type	材质 Material	颜色 Color	重量 Weight (KG/M)
HarH611	PE+Aluminum	Green/White	0.65

Remark: this type product is 3m/PC.

HarH612 Series Guide Rails

HarH612型圆帽护栏

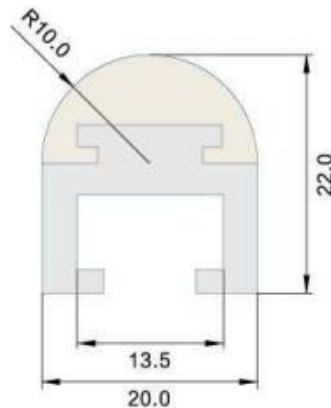
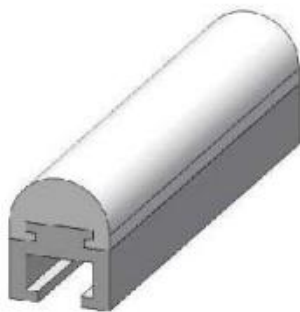

型号 Type	材质 Material	颜色 Color	重量 Weight (KG/M)
HarH612	PE+Aluminum	Green/White	0.52

Remark: this type product is 3m/PC.

HarH613 Series Guide Rails

HarH613型圆帽护栏

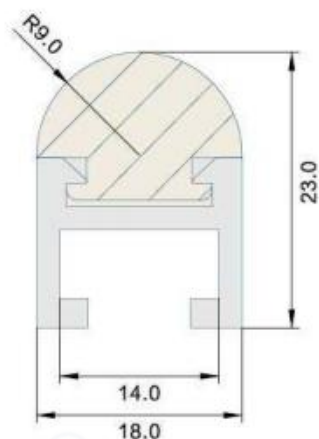
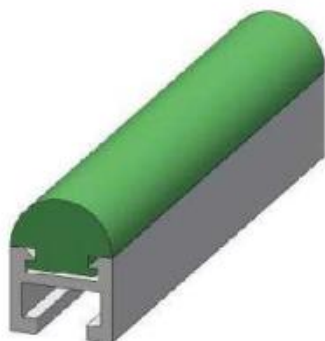

型号 Type	材质 Material	颜色 Color	重量 Weight (KG/M)
HarH613	PE+Aluminum	Green/White	0.55

Remark: this type product is 3m/PC.

HarH614 Series Guide Rails

HarH614型圆帽护栏

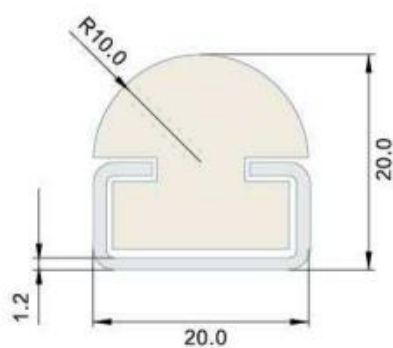
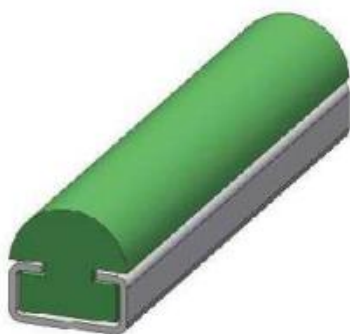

型号 Type	材质 Material	颜色 Color	重量 Weight (KG/M)
HarH614	PE+SUS	Green/White	0.6

Remark: this type product is 3m/PC.

HarH615 Series Guide Rails

HarH615型小C护栏

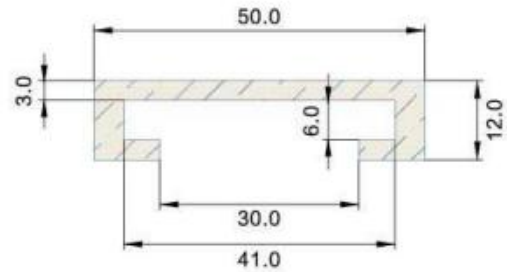
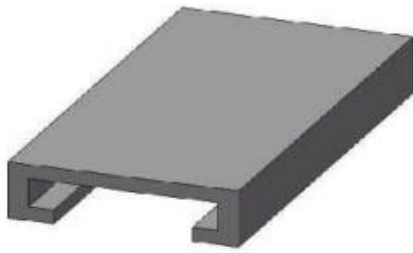

型号 Type	材质 Material	颜色 Color	重量 Weight (KG/M)
HarH615	PE+SUS	Green/White	0.15

Remark: this type product is 3m/PC.

HarH616 Series Guide Rails

HarH616型小C护栏

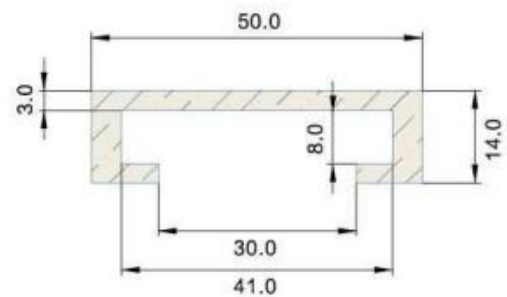
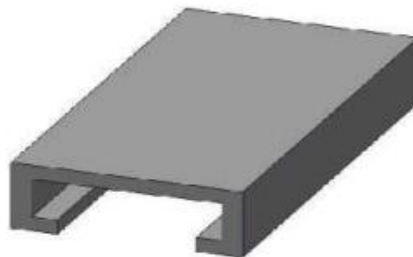

型号 Type	材质 Material	颜色 Color	重量 Weight (KG/M)
HarH616	PE+SUS	Green/White	0.5

Remark: this type product is 3m/PC.

配件 Accessories

HarH617 Series Guide Rails

HarH617型 平行垫轨

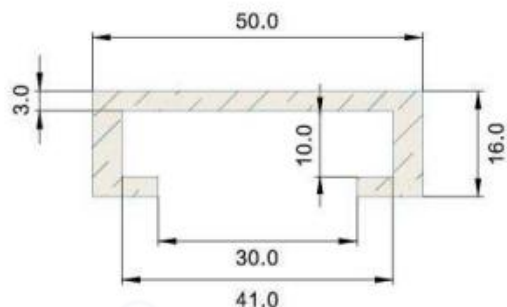
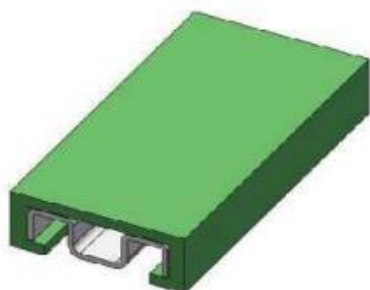

型号 Type	材质 Material	颜色 Color	重量 Weight (KG/M)
HarH617	PE+SUS	Green/White	0.6

Remark: this type product is 3m/PC.

HarH618 Series Guide Rails

HarH618型 侧边垫轨

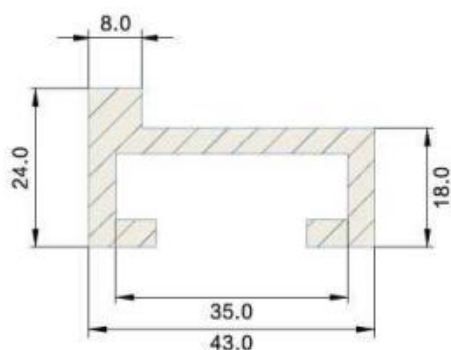
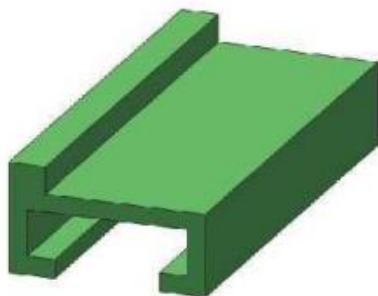

型号 Type	材质 Material	颜色 Color	重量 Weight (KG/M)
HarH618	PE+SUS	Green	0.28

Remark: this type product is 3m/PC.

HarH619 Series Guide Rails

HarH619型 侧边垫轨

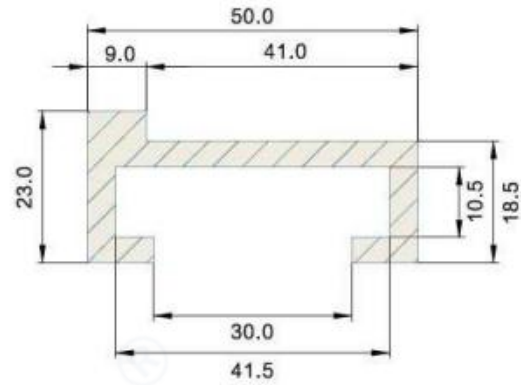
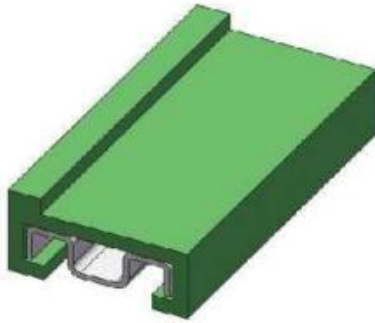

型号 Type	材质 Material	颜色 Color	重量 Weight (KG/M)
HarH619	PE+SUS	Green	1.0

Remark: this type product is 3m/PC.

HarH620 Series Guide Rails

HarH620型大C护栏

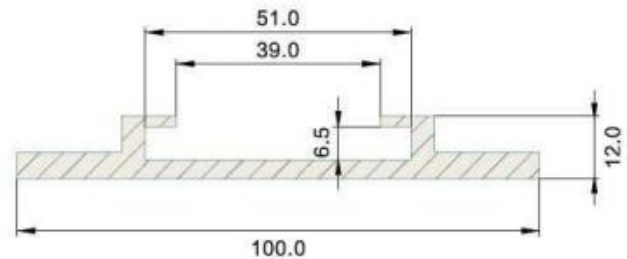

型号 Type	材质 Material	颜色 Color	重量 Weight (KG/M)
HarH620	PE+Aluminum	White	0.9

Remark: this type product is 3m/PC.

HarH621 Series Guide Rails

HarH621型大C护栏

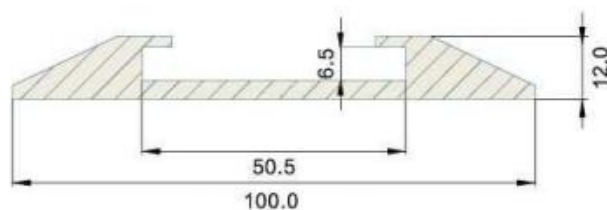
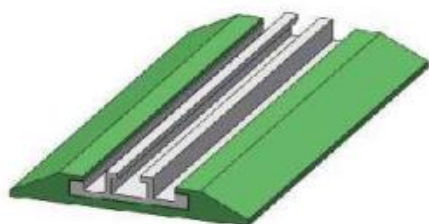

型号 Type	材质 Material	颜色 Color	重量 Weight (KG/M)
HarH621	PE+Aluminum	Green	1.2

Remark: this type product is 3m/PC.

HarH622 Series Guide Rails

HarH622型大C护栏

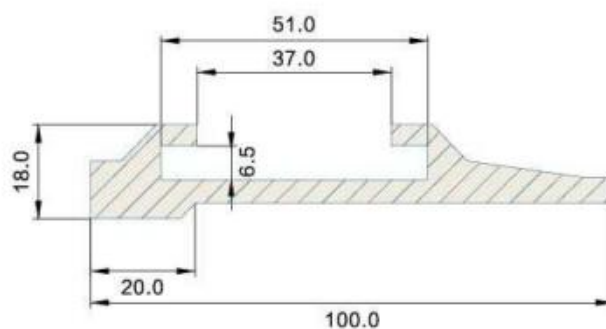

型号 Type	材质 Material	颜色 Color	重量 Weight (KG/M)
HarH622	PE+Aluminum	Green/Blue	1.2

Remark: this type product is 3m/PC.

HarH623 Series Guide Rails

HarH623型大C护栏

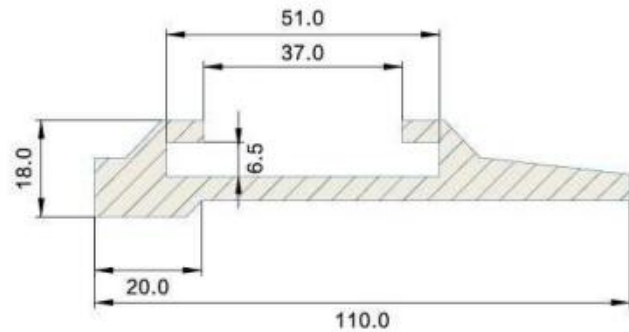
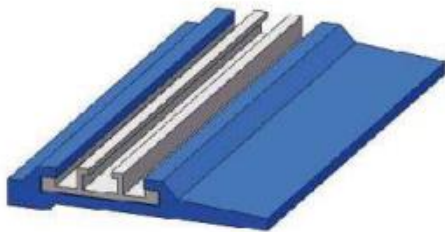

型号 Type	材质 Material	颜色 Color	重量 Weight (KG/M)
HarH623	PE+Aluminum	Green/Blue	1.4

Remark: this type product is 3m/PC.

HarH624 Series Guide Rails

HarH624型大C护栏

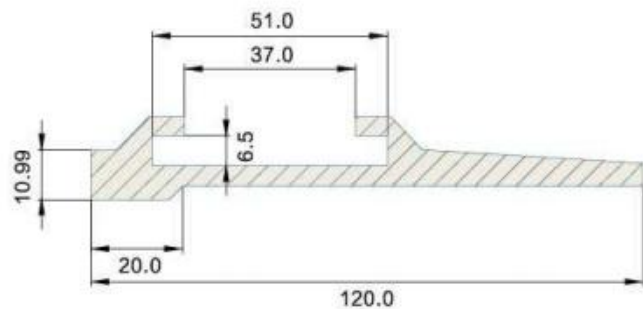

型号 Type	材质 Material	颜色 Color	重量 Weight (KG/M)
HarH624	PE+Aluminum	Green/Blue	1.6

Remark: this type product is 3m/PC.

HarH625 Series Guide Rails

HarH625型大C护栏

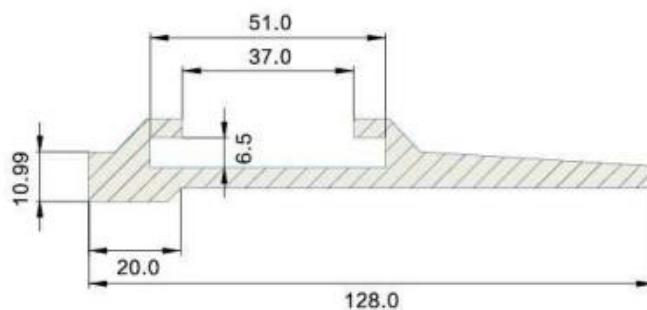

型号 Type	材质 Material	颜色 Color	重量 Weight (KG/M)
HarH625	PE+Aluminum	Green/Blue	1.25

Remark: this type product is 3m/PC.

HarH626 Series Guide Rails

HarH626型大C护栏

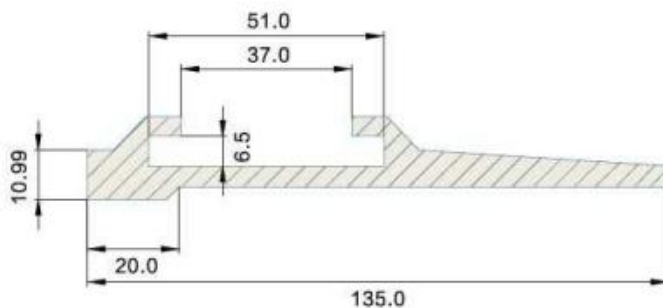

型号 Type	材质 Material	颜色 Color	重量 Weight (KG/M)
HarH626	PE+Aluminum	Green/Blue	1.25

Remark: this type product is 3m/PC.

HarH627 Series Guide Rails

HarH627型弓形钢护栏

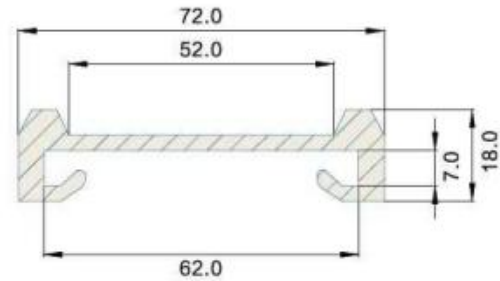
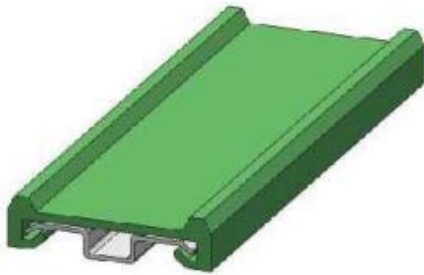

型号 Type	材质 Material	颜色 Color	重量 Weight (KG/M)
HarH627	PE+SUS	Green/Black	0.9

Remark: this type product is 3m/PC.

HarH628 Series Guide Rails

HarH628型弓形钢护栏

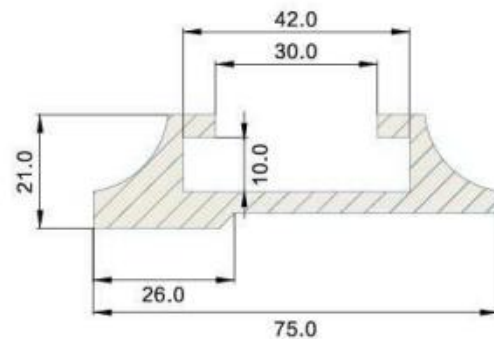
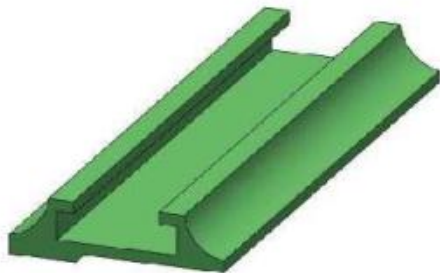

型号 Type	材质 Material	颜色 Color	重量 Weight (KG/M)
HarH628	PE+SUS	Green/Black	0.6

Remark: this type product is 3m/PC.

HarH629 Series Guide Rails

HarH629型弓形钢护栏

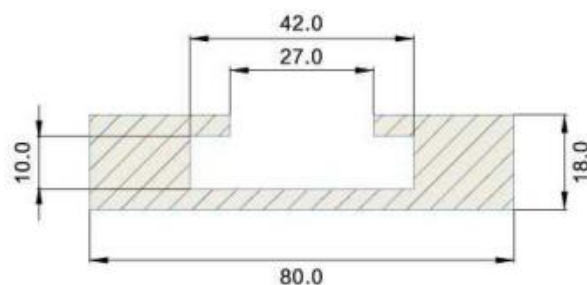

型号 Type	材质 Material	颜色 Color	重量 Weight (KG/M)
HarH629	PE+SUS	Green/Black	1.05

Remark: this type product is 3m/PC.

HarH630 Series Guide Rails

HarH630型弓形钢护栏

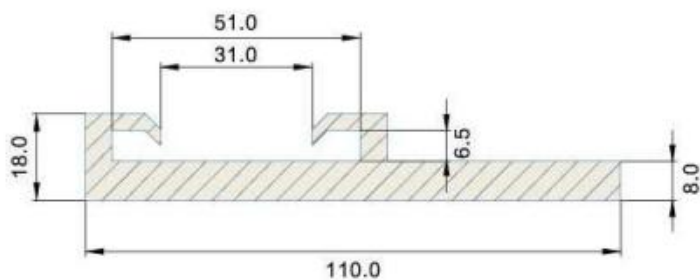
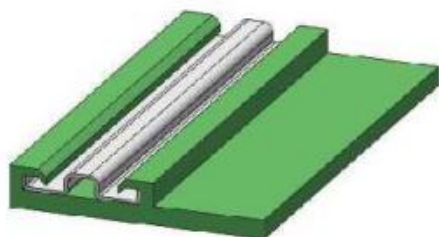

型号 Type	材质 Material	颜色 Color	重量 Weight (KG/M)
HarH630	PE+SUS	Green/Black	1.15

Remark: this type product is 3m/PC.

HarH631 Series Guide Rails

HarH631型护栏

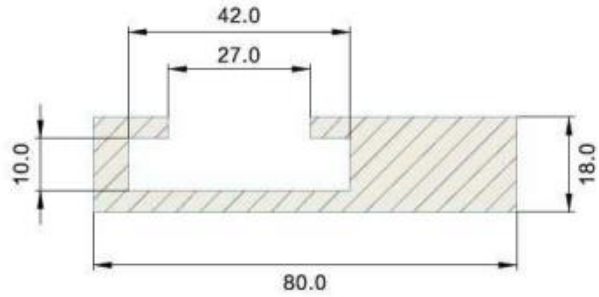
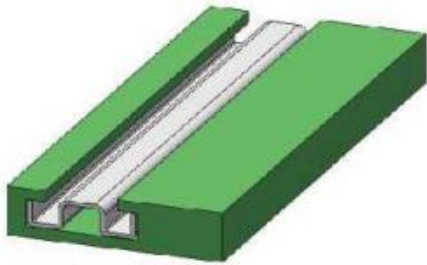

型号 Type	材质 Material	颜色 Color	重量 Weight (KG/M)
HarH631	PE+SUS	Black/Green	1.05

Remark: this type product is 3m/PC.

HarH632 Series Guide Rails

HarH632型护栏

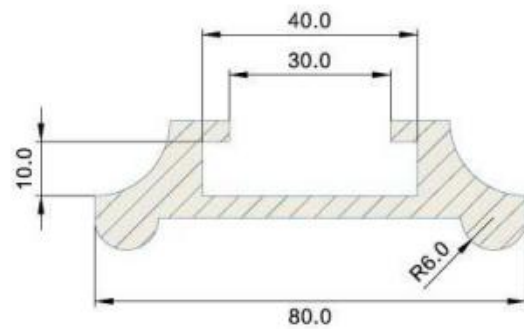

型号 Type	材质 Material	颜色 Color	重量 Weight (KG/M)
HarH632	PE+SUS	Black/Green	1.10

Remark: this type product is 3m/PC.

HarH633 Series Guide Rails

HarH633型护栏

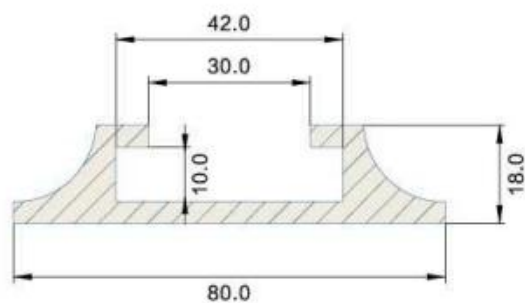

型号 Type	材质 Material	颜色 Color	重量 Weight (KG/M)
HarH633	PE+SUS	Green/Blue	0.9

Remark: this type product is 3m/PC.

HarH634 Series Guide Rails

HarH634型护栏

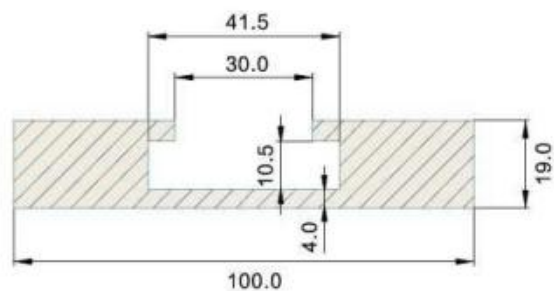

型号 Type	材质 Material	颜色 Color	重量 Weight (KG/M)
HarH634	PE+SUS	Black/Green	1.05

Remark: this type product is 3m/PC.

HarH635 Series Guide Rails

HarH635型护栏

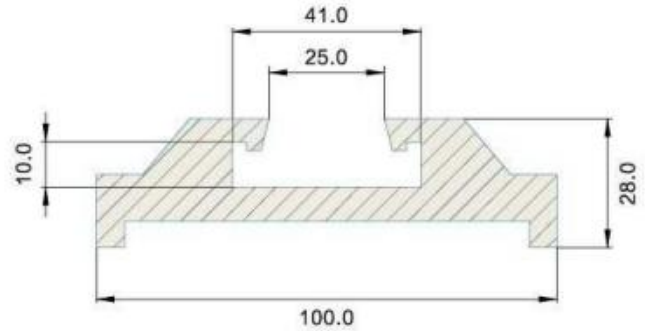
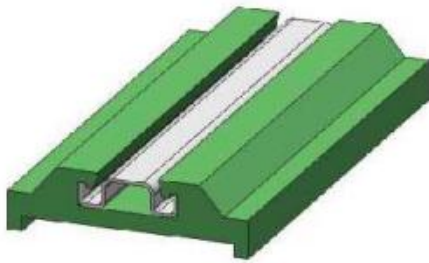

型号 Type	材质 Material	颜色 Color	重量 Weight (KG/M)
HarH635	PE+SUS	Black/Green	1.15

Remark: this type product is 3m/PC.

HarH636 Series Guide Rails

HarH636型护栏

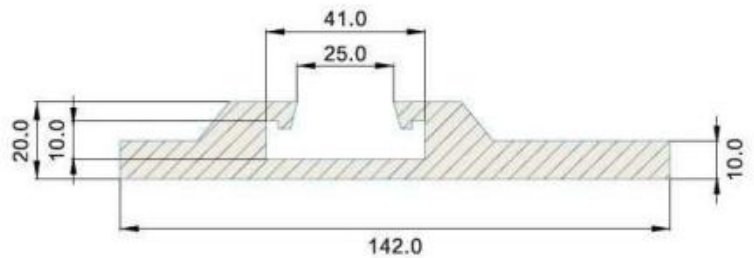
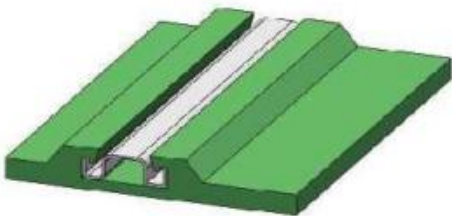

型号 Type	材质 Material	颜色 Color	重量 Weight (KG/M)
HarH636	PE+SUS	Black/Green	1.2

Remark: this type product is 3m/PC.

HarH637 Series Guide Rails

HarH637型护栏

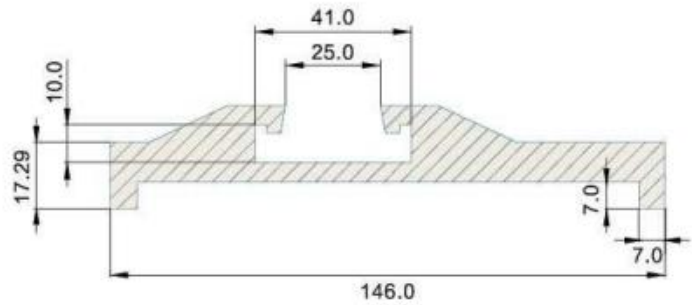
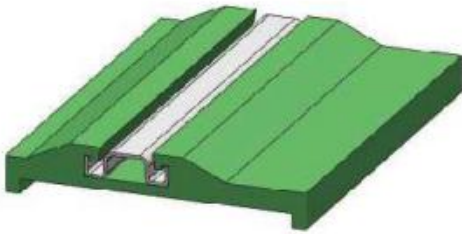

型号 Type	材质 Material	颜色 Color	重量 Weight (KG/M)
HarH637	PE+SUS	Black/Green	1.65

Remark: this type product is 3m/PC.

HarH638 Series Guide Rails

HarH638型护栏

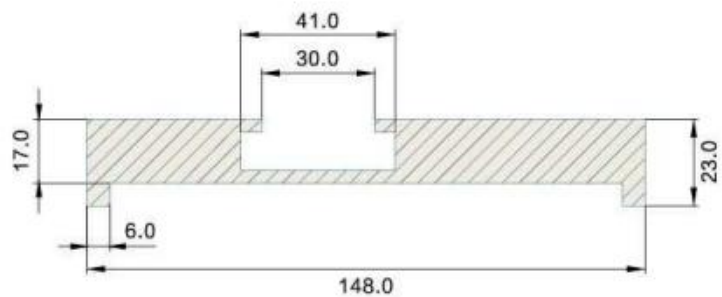
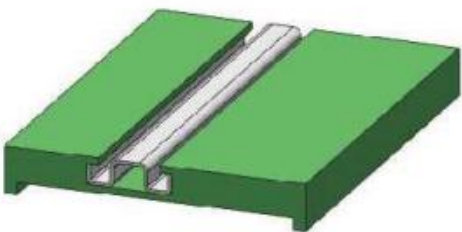

型号 Type	材质 Material	颜色 Color	重量 Weight (KG/M)
HarH638	PE+SUS	Black/Green	1.62

Remark: this type product is 3m/PC.

HarH639 Series Guide Rails

HarH639型护栏

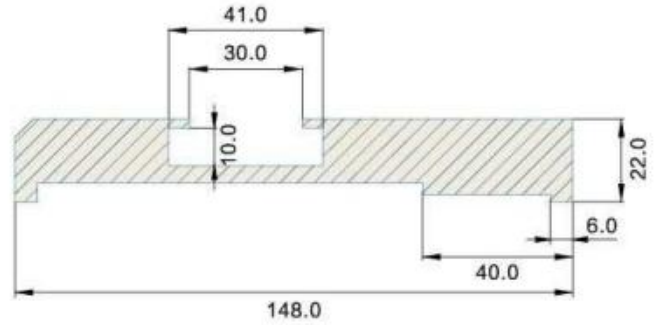

型号 Type	材质 Material	颜色 Color	重量 Weight (KG/M)
HarH639	PE+SUS	Black/Green	1.62

Remark: this type product is 3m/PC.

HarH640 Series Guide Rails

HarH640型护栏

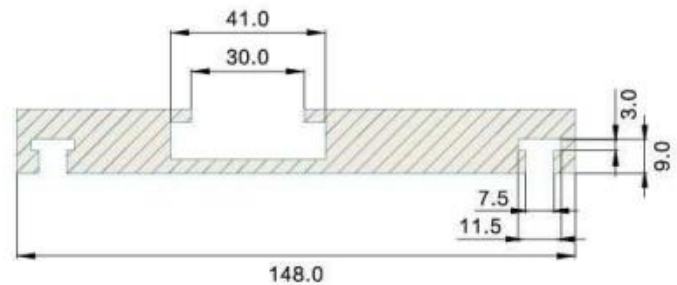
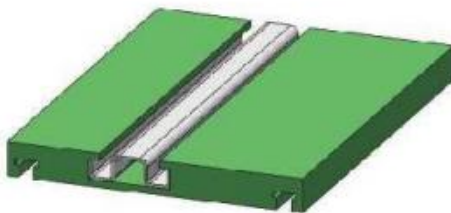

型号 Type	材质 Material	颜色 Color	重量 Weight (KG/M)
HarH640	PE+SUS	Black/Green	1.53

Remark: this type product is 3m/PC.

HarH637-1 Series Guide Rails

HarH637-1型 侧边垫轨

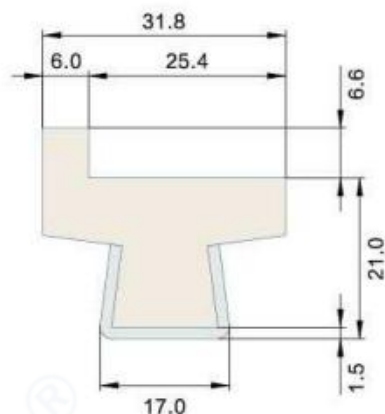
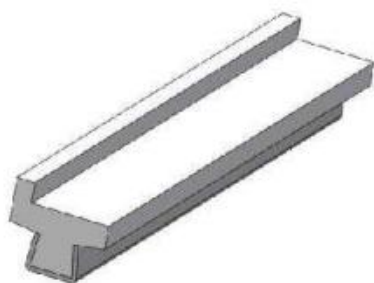

型号 Type	材质 Material	颜色 Color	重量 Weight (KG/M)
HarH637-1	PE+SUS UHMWPE+ SUS	White	0.9

Remark: this type product is 3m/PC.

HarH638-1 Series Guide Rails

HarH638-1型 中间垫轨

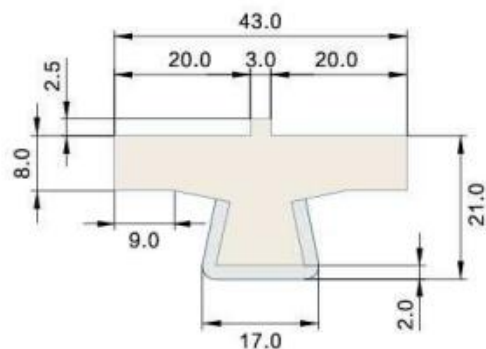
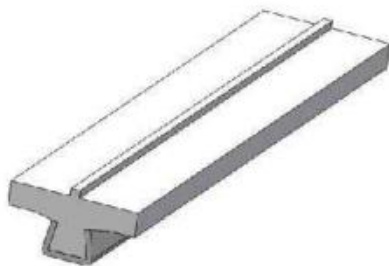

型号 Type	材质 Material	颜色 Color	重量 Weight (KG/M)
HarH638-1	PE+SUS UHMWPE+ SUS	White	1.0

Remark: this type product is 3m/PC.

HarH639-1 Series Rails

HarH639-1弓形钢

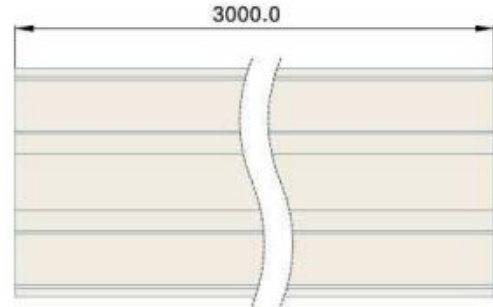
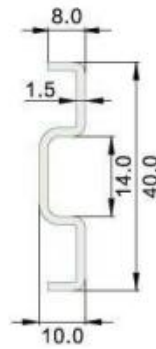

型号 Type	材质 Material	颜色 Color	重量 Weight (KG/M)
HarH639-1	SUS	Nature	0.62

Remark: this type product is 3m/PC.

HarH640-1 Series Rails

HarH640-1护栏配套不锈钢型材

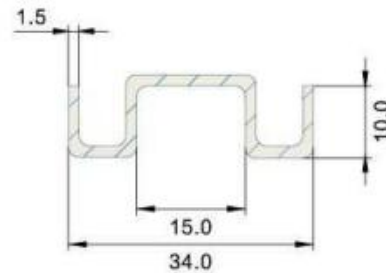
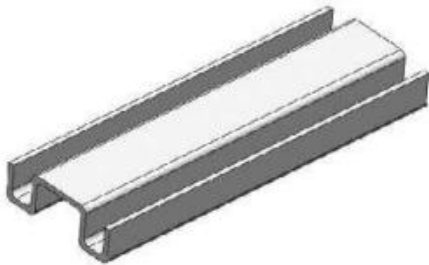

型号 Type	材质 Material	颜色 Color	重量 Weight (KG/M)
HarH640-1	SUS	Nature	0.5

Remark: this type product is 3m/PC.

HarH641 Series Rails

HarH641配套护栏弓形钢

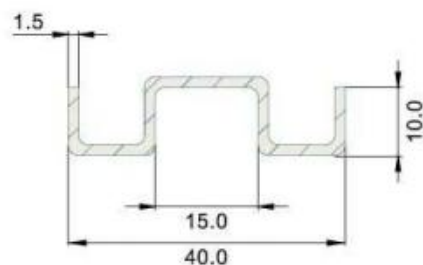
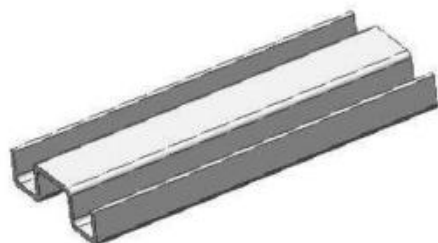

型号 Type	材质 Material	颜色 Color	重量 Weight (KG/M)
HarH641	SUS	Nature	0.6

Remark: this type product is 3m/PC.

HarH642 Series Steel Rails

HarH642护栏弓形钢

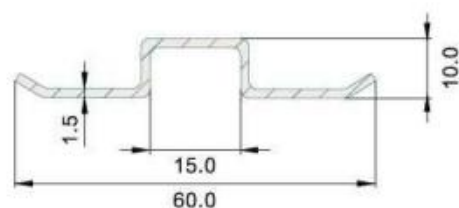
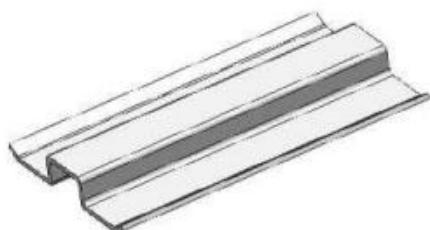

型号 Type	材质 Material	颜色 Color	重量 Weight (KG/M)
HarH642	SUS	Nature	0.72

Remark: this type product is 3m/PC.

HarH643 Series Steel Rails

HarH643护栏弓形钢

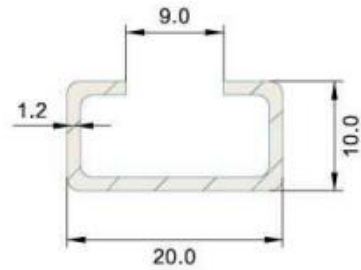
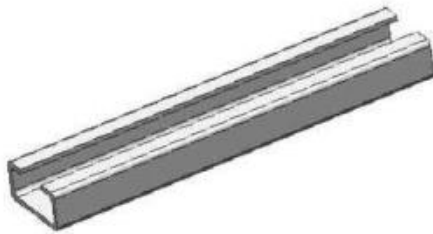

型号 Type	材质 Material	颜色 Color	重量 Weight (KG/M)
HarH643	SUS	Nature	0.37

Remark: this type product is 3m/PC.

HarH644 Series Rails

HarH644小C 护栏配套铝型材

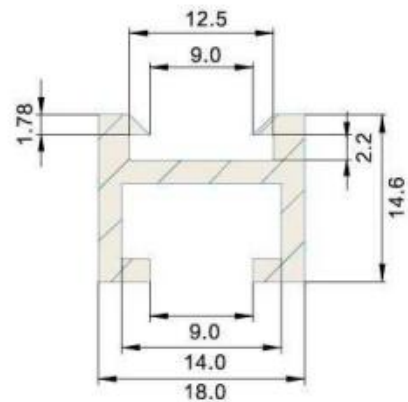
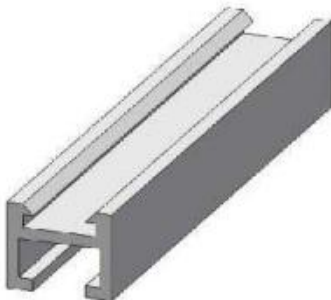

型号 Type	材质 Material	颜色 Color	重量 Weight (KG/M)
HarH644	Aluminium	Nature	0.9

Remark: this type product is 3m/PC.

HarH645 Series Steel Rails

HarH645小C 护栏配套铝型材

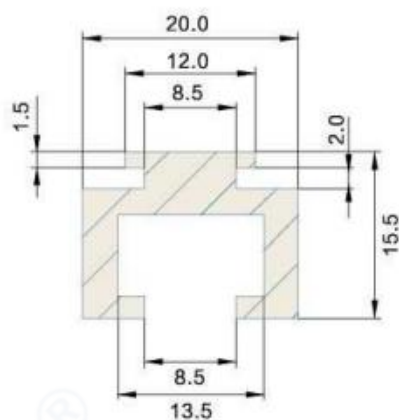
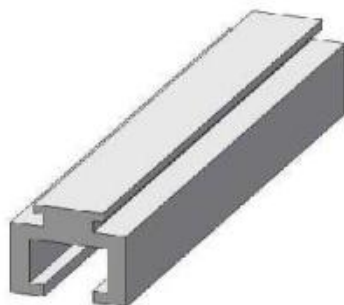

型号 Type	材质 Material	颜色 Color	重量 Weight (KG/M)
HarH645	Aluminium	Nature	0.32

Remark: this type product is 3m/PC.

HarH646 Series Steel Rails

HarH646大C 护栏配套铝型材

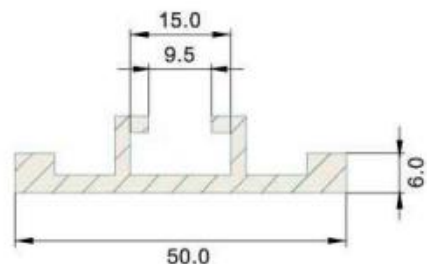

型号 Type	材质 Material	颜色 Color	重量 Weight (KG/M)
HarH646	Aluminium	Nature	0.5

Remark: this type product is 3m/PC.

HarH647 Series Rails Connect Plate

HarH647型大C护栏连接片

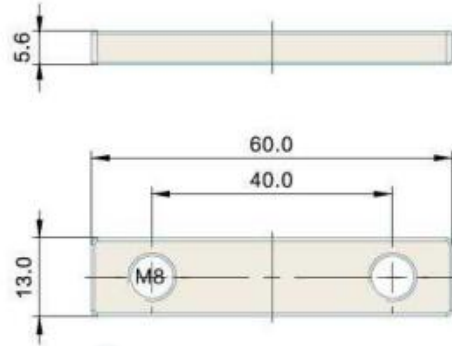
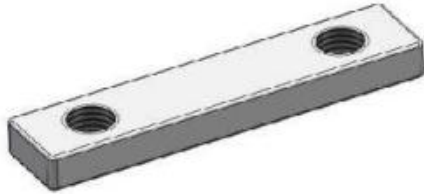

型号 Type	材质 Material	颜色 Color	重量 Weight (KG/M)
HarH647	SUS	Nature	0.45

Remark: this type product is 3m/PC.

HarH648 Series Rails

HarH648弓形钢连接杆

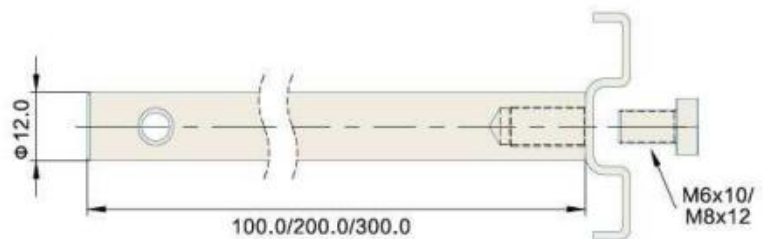

型号 Type	材质 Material	颜色 Color	重量 Weight (KG/M)
HarH648	SUS	Nature	0.35

HarH649 Series Rails

HarH649型侧边垫轨

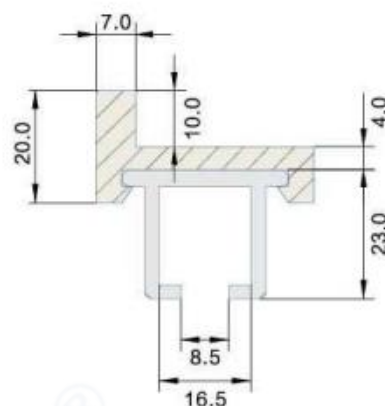
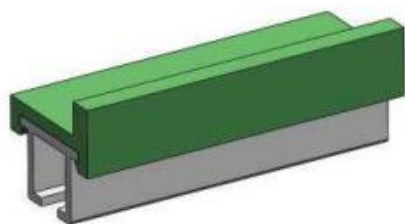

型号 Type	材质 Material	颜色 Color	重量 Weight (KG/M)
HarH649	PE+Aluminium	Green/White	0.58

Remark: this type product is 3m/PC.

HarH650 Series Rails

HarH650型侧边垫轨

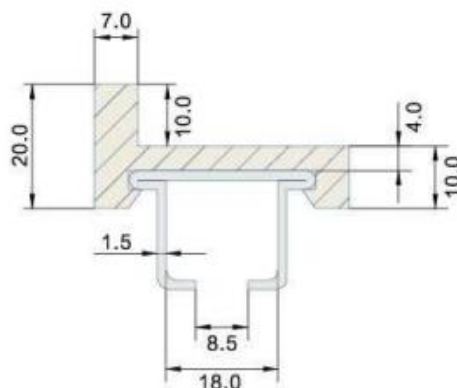
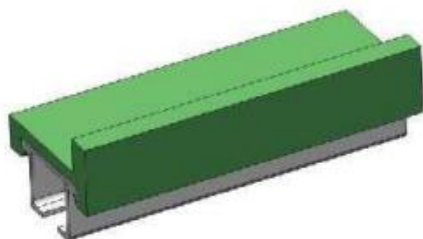

型号 Type	材质 Material	颜色 Color	重量 Weight (KG/M)
HarH650	PE+SUS	Green/White	0.73

Remark: this type product is 3m/PC.

HarH651 Series Rails

HarH651型平行垫轨

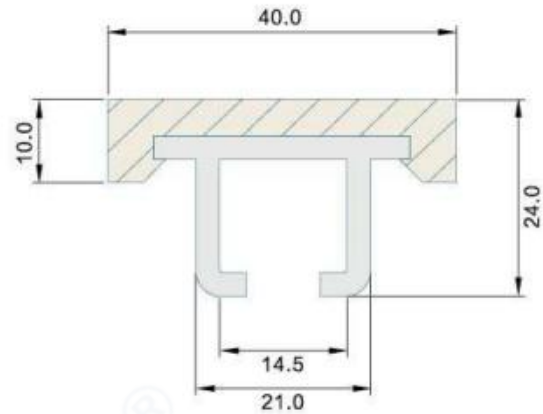
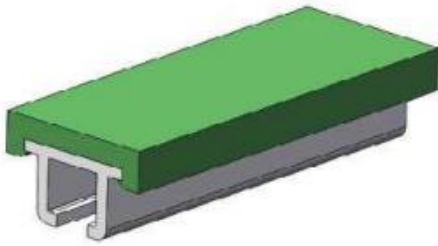

型号 Type	材质 Material	颜色 Color	重量 Weight (KG/M)
HarH651	PE+Aluminium	Green/White	0.52

Remark: this type product is 3m/PC.

HarH652 Series Rails

HarH652型不锈钢平行垫轨

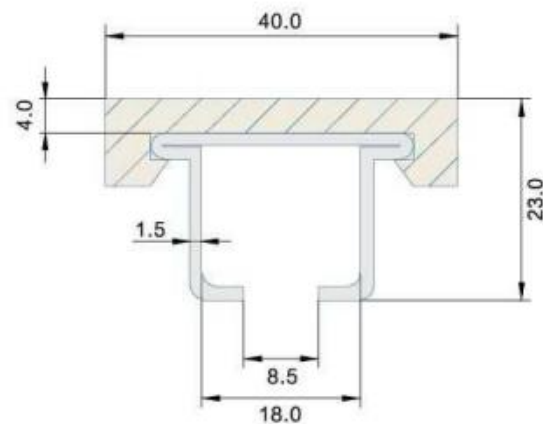
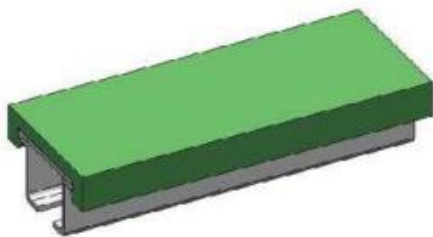

型号 Type	材质 Material	颜色 Color	重量 Weight (KG/M)
HarH652	PE+SUS	Green/White	0.67

Remark: this type product is 3m/PC.

HarH653 Series Rails

HarH653型中间垫轨

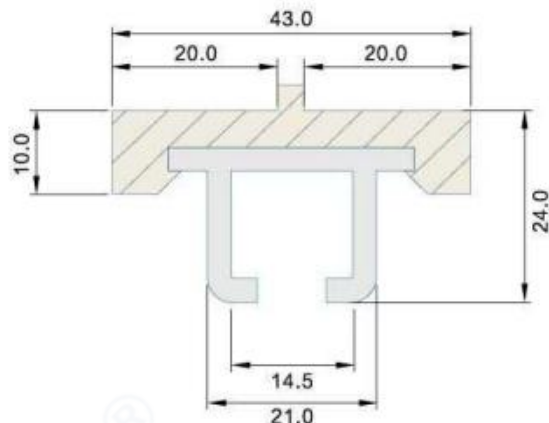
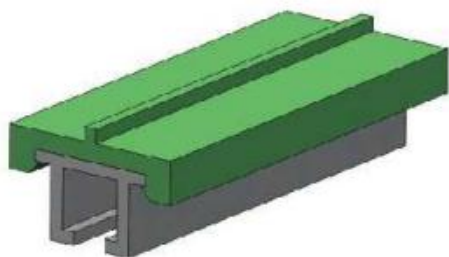

型号 Type	材质 Material	颜色 Color	重量 Weight (KG/M)
HarH653	PE+Aluminium	Green	0.54

Remark: this type product is 3m/PC.

HarH654 Series Rails

HarH654型中间垫轨

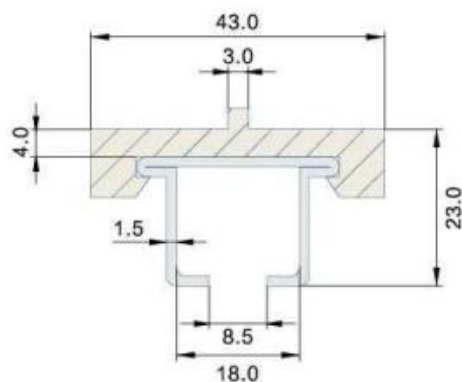
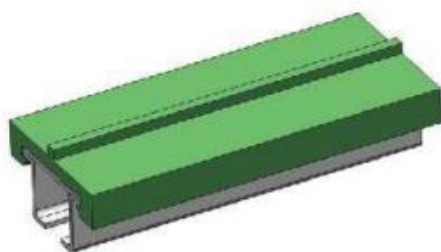

型号 TYPE	材质 MATERIAL	颜色 COLOR	重量 WEIGHT (KG/M)
HarH654	PE+SUS	Green	0.7

Remark: this type product is 3m/PC.

HarH655 Series Rails

HarH655不锈钢垫轨型材

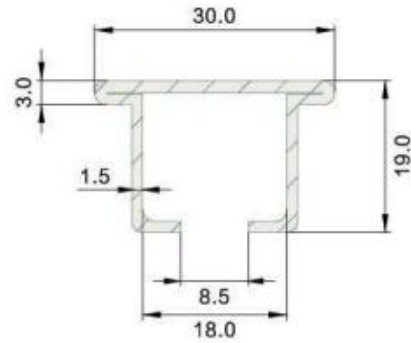
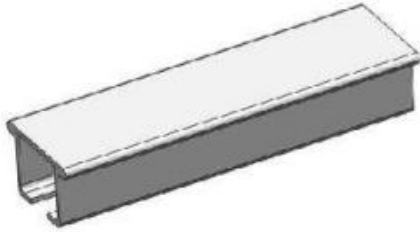

型号 Type	材质 Material	颜色 Color	重量 Weight (KG/M)
HarH655	SUS	Nature	0.5

Remark: this type product is 3m/PC.

HarH656 Series Steel Rails

HarH656平行垫轨型材

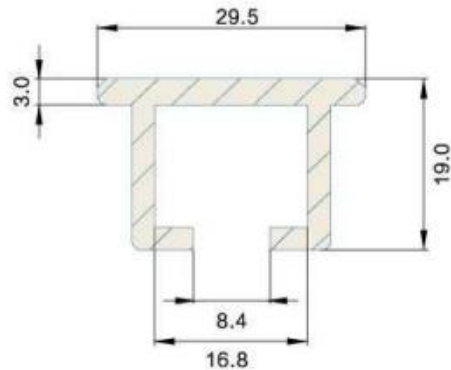
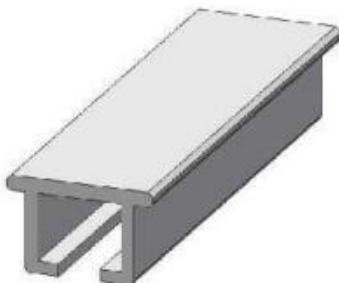

型号 Type	材质 Material	颜色 Color	重量 Weight (KG/M)
HarH656	Aluminium	Nature	0.5

Remark: this type product is 3m/PC.

HarH657 Series Rails

HarH657平行垫轨型材

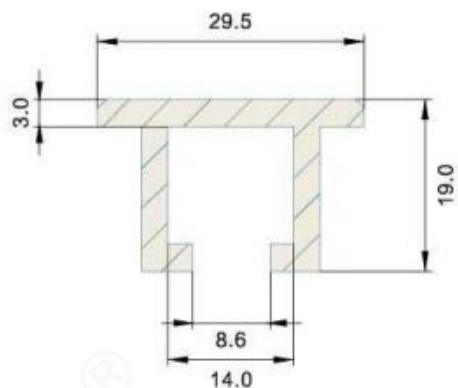

型号 Type	材质 Material	颜色 Color	重量 Weight (KG/M)
HarH657	Aluminium	Nature	0.5

Remark: this type product is 3m/PC.

HarH658 Series Rails

HarH658平行垫轨型材

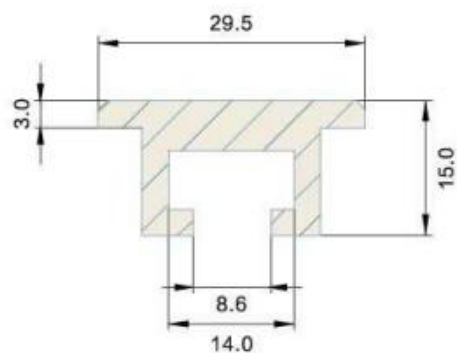
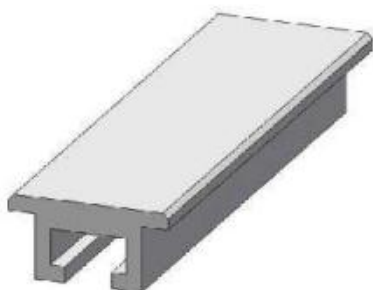

型号 Type	材质 Material	颜色 Color	重量 Weight (KG/M)
HarH658	Aluminium	Nature	0.5

Remark: this type product is 3m/PC.

HarH659 Series Guide Rails

HarH659型弓形钢护栏

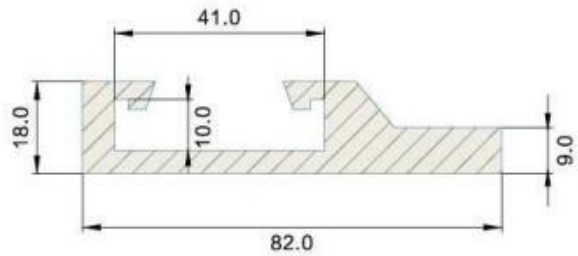
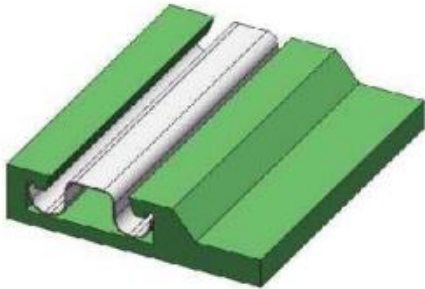

型号 TYPE	材质 MATERIAL	颜色 COLOR	重量 WEIGHT (KG/M)
HarH659	PE+SUS	Black/Green	0.65

Remark: this type product is 3m/PC.

HarH608-1 Roller Guide Rails

HarH608-1型护栏

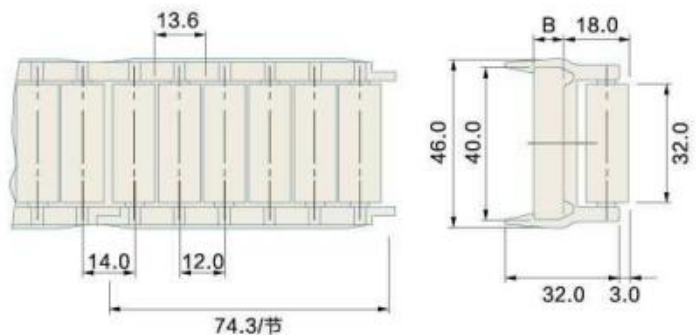

型号 Type	材质 Material	颜色 Color	重量 Weight (KG/M)
HarH608-1	POM+SUS	White	0.65

Remark: this type product is 3m/PC.

HarH609-1 Roller Guide Rails

HarH609-1型护栏

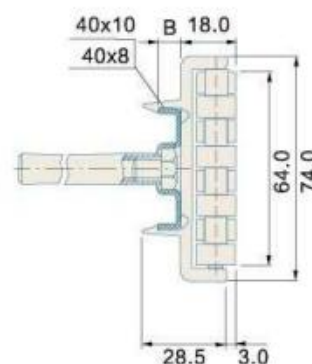
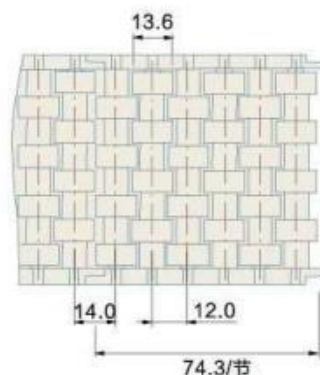

型号 Type	材质 Material	颜色 Color	重量 Weight (KG/M)
HarH609-1	POM+SUS	White	1.04

Remark: this type product is 3m/PC.

HarH610-1 Roller Guide Rails

HarH610-1型滚珠护栏

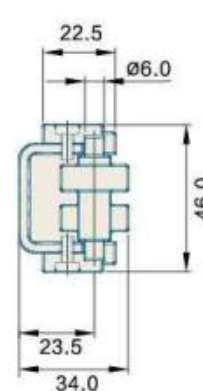
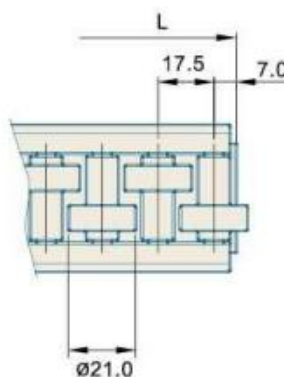

型号 Type	材质 Material	颜色 Color	重量 Weight (KG/M)
HarH610-1	POM+SUS	White	2.2

Remark: this type product is 3m/PC.

HarH610-2 Roller Guide Rails

HarH610-2型滚珠护栏

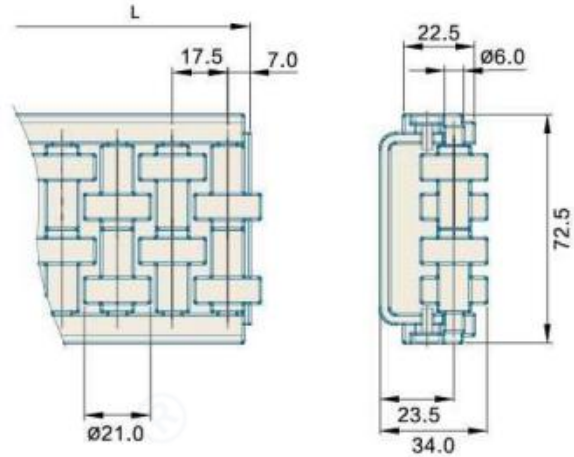

型号 Type	材质 Material	颜色 Color	重量 Weight (KG/M)
HarH610-2	POM+SUS	White	3.5

Remark: this type product is 3m/PC.

HarH610-3 Roller Guide Rails

HarH610-3型滚珠护栏

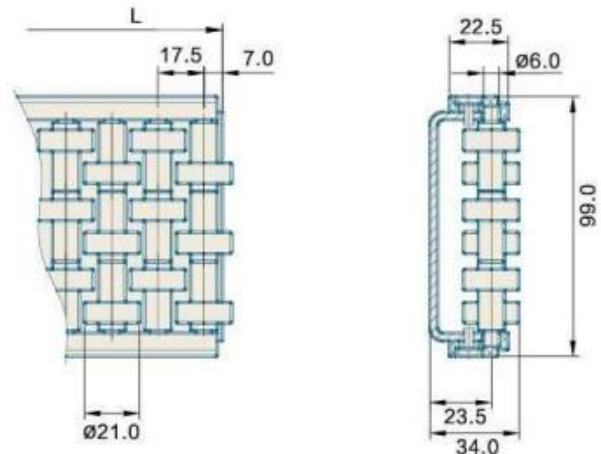

型号 Type	材质 Material	颜色 Color	重量 Weight (KG/M)
HarH610-3	POM+SUS	White	4.7

Remark: this type product is 3m/PC.

HarH610-4 Roller Guide Rails

HarH610-4型滚珠护栏

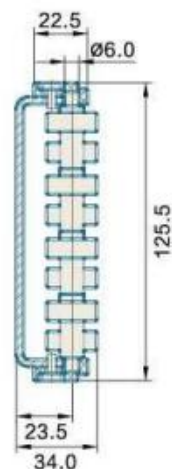
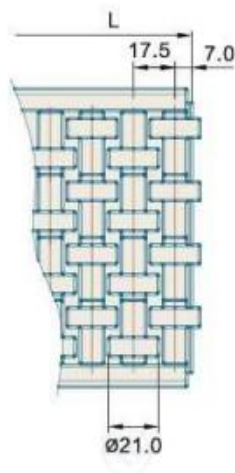

型号 Type	材质 Material	颜色 Color	重量 Weight (KG/M)
HarH610-4	POM+SUS	White	6.0

Remark: this type product is 3m/PC.

HarH611-1 Roller Guide Rails

HarH611-1型护栏

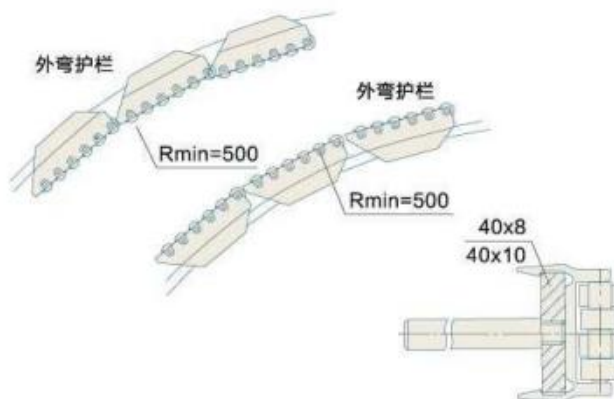

型号 Type	材质 Material	颜色 Color	重量 Weight (KG/M)
HarH611-1	POM+SUS	White	0.65

Remark: this type product is 3m/PC.

HarH612-1 Roller Guide Rails

HarH612-1型护栏

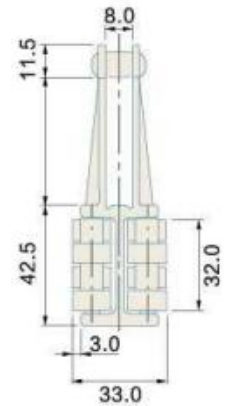
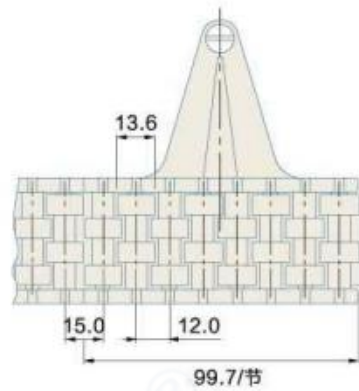

型号 Type	材质 Material	颜色 Color	重量 Weight (KG/M)
HarH612-1	POM+SUS	White	1

Remark: this type product is 3m/PC.

HarH615-1 Roller Guide Rails

HarH615-1型滚珠护栏

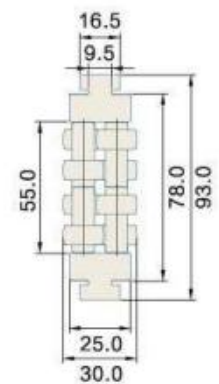
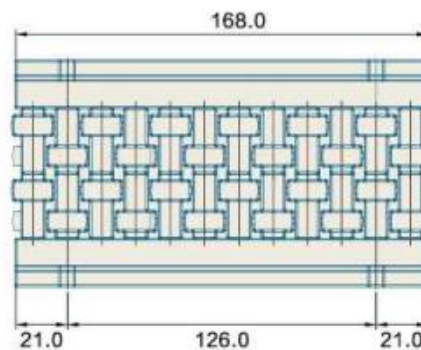
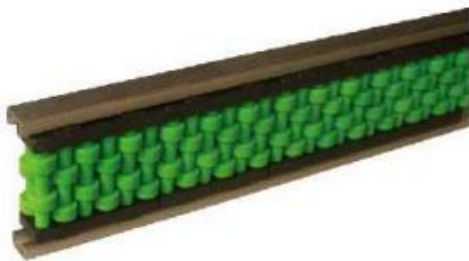

型号 Type	材质 Material	颜色 Color	重量 Weight (KG/M)
HarH615-1	POM+SUS	Green	5.6

Remark: this type product is 3m/PC.

HarH668 Series Roller Guide Rails

HarH668型滚珠护栏

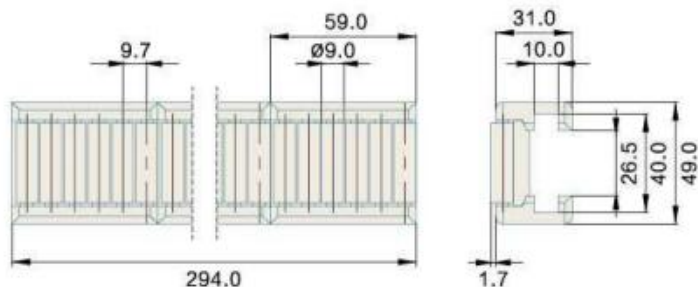

型号 Type	材质 Material	颜色 Color
HarH668	POM+SUS	Brown Roller + Black Shell

Remark: this type product is 3m/PC.

HarH669 Series Roller Guide Rails

HarH669型护栏

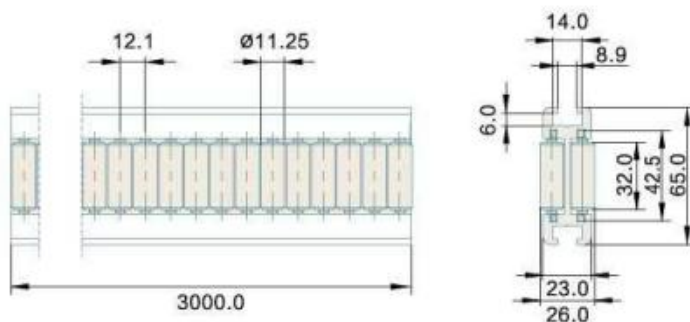
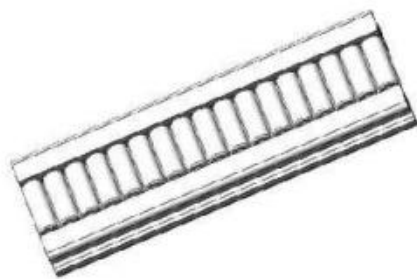

型号 Type	材质 Material	颜色 Color	重量 Weight (KG/M)
HarH669	PE+Aluminium	Green	0.53

Remark: this type product is 3m/PC.

HarH670 Roller Guide Rails

HarH670型护栏

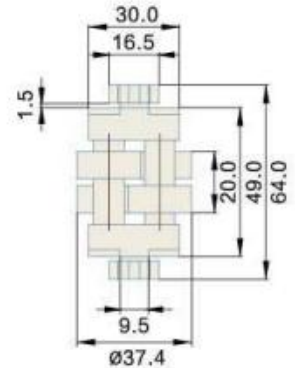
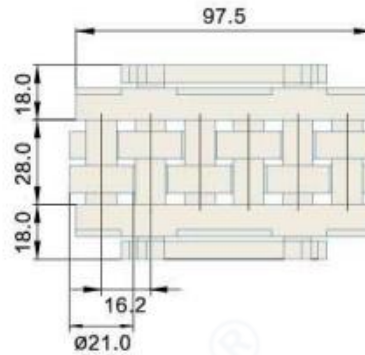

型号 Type	材质 Material	颜色 Color	重量 Weight (KG/M)
HarH670	POM+SUS	Green	0.65

Remark: this type product is 3m/PC.

HarH671 Roller Guide Rails

HarH671型护栏

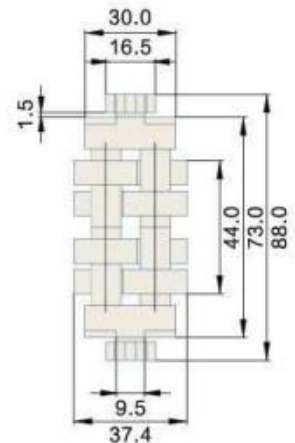
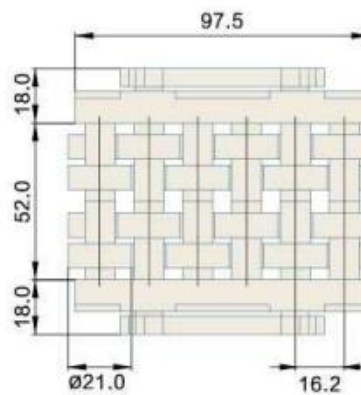

型号 Type	材质 Material	颜色 Color	重量 Weight (KG/M)
HarH671	POM+SUS	Green	0.65

Remark: this type product is 3m/PC.

HarH672 Roller Guide Rails

HarH672型护栏

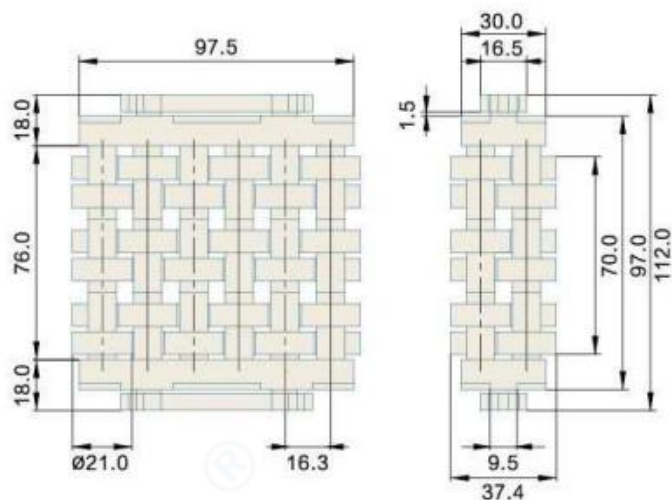

型号 Type	材质 Material	颜色 Color	重量 Weight (KG/M)
HarH672	POM+SUS	Green	0.65

Remark: this type product is 3m/PC.

HarH660 Series Guide Rails

HarH660型钢护栏

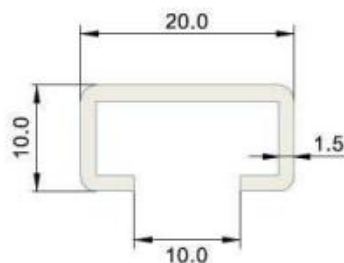
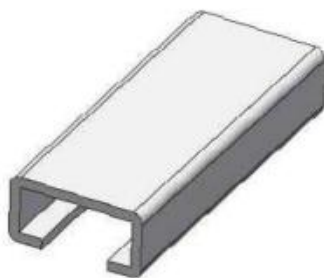

型号 Type	材质 Material	颜色 Color	重量 Weight (KG/M)
HarH660	SUS304	Nature	1.42

Remark: this type product is 3m/PC.

HarH673 Series Connected Part

HarH673分道护栏连接片

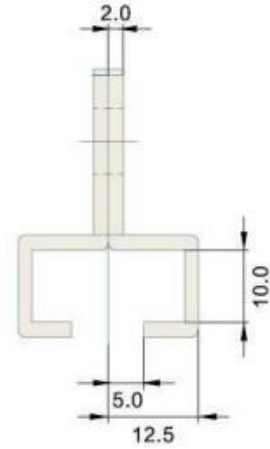
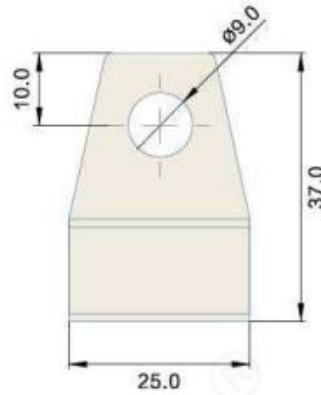
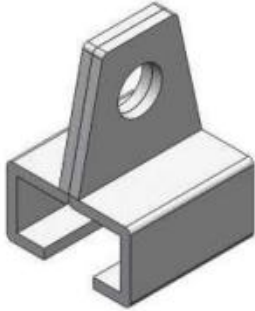

型号 Type	材质 Material	颜色 Color	重量 Weight (KG/M)
HarH673	SUS304	Nature	0.25

HarH674 Roller Guide Rails

HarH674流利条

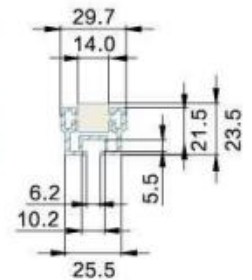
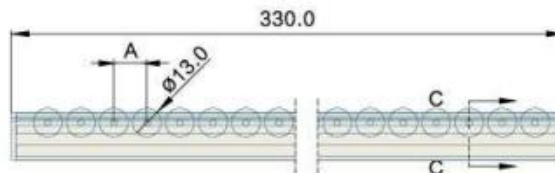

型号 Type	材质 Material	颜色 Color	重量 Weight (KG/M)
HarH674	POM+Aluminium	Yellow	1.15

Remark: this type product is 3m/PC.

HarH675 Roller Guide Rails

HarH675流利条

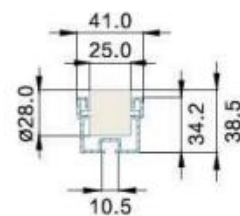
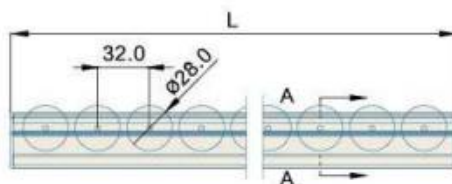

型号 Type	材质 Material	颜色 Color	重量 Weight (KG/M)
HarH675	POM+Aluminium	Yellow	1.15

Remark: this type product is 3m/PC.



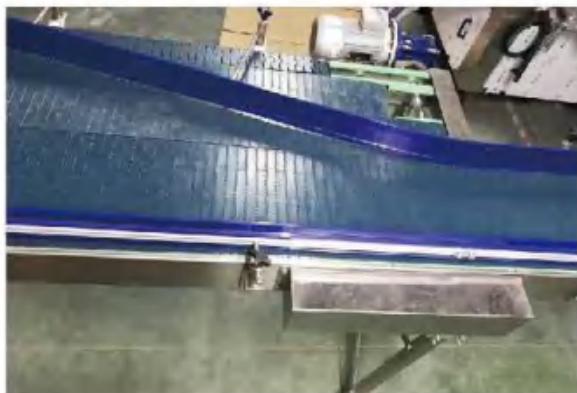
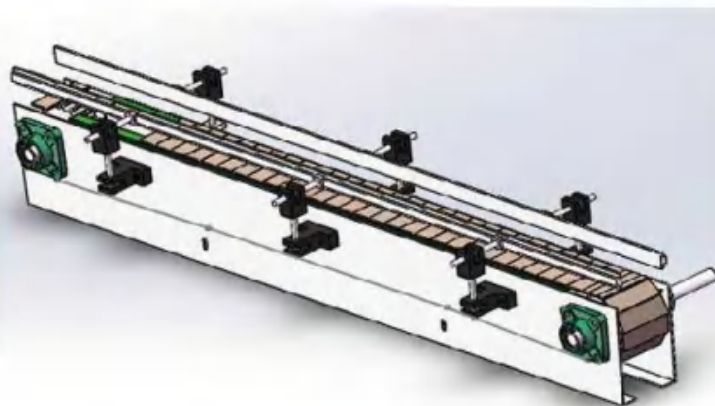
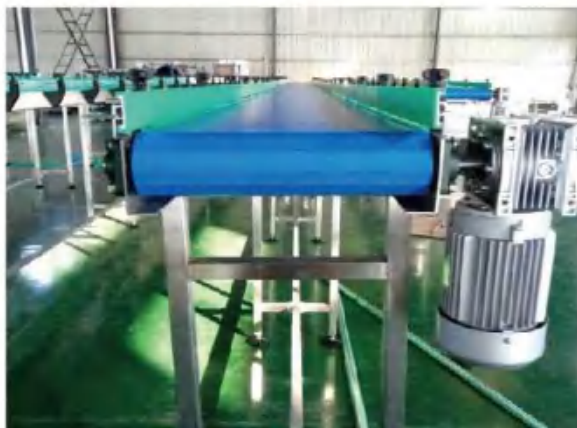

N01 Neck Guides

N01 宝特瓶风送条

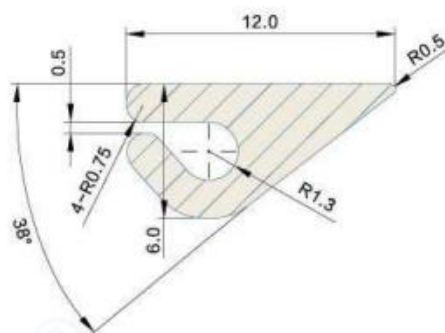

型号 Type	材质 Material	颜色 Color
N01	UHMW-PE1000	灰色 Grey

N02 Neck Guides

N02 宝特瓶风送条

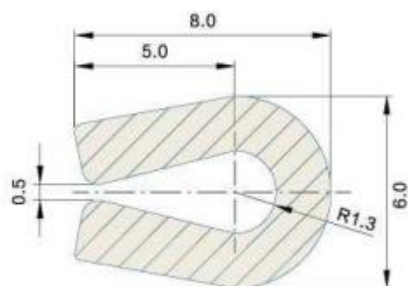

型号 Type	材质 Material	颜色 Color
N02	UHMW-PE1000	灰色 Grey

N03 Neck Guides

N03 机加工风送条

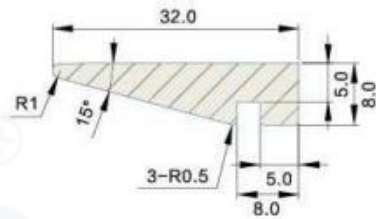
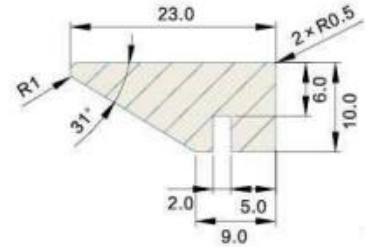
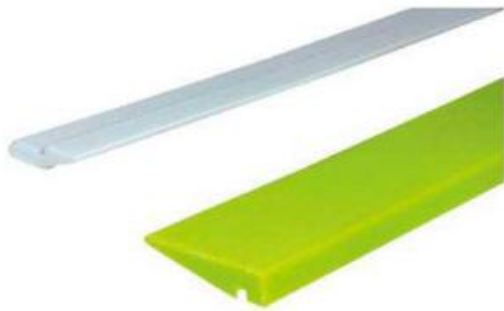

型号 Type	材质 Material	颜色 Color
N03	UHMW-PE1200	绿色 Green

N04 Neck Guides

N04 机加工风送条

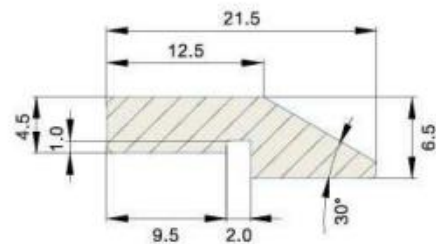

型号 Type	材质 Material	颜色 Color
N04	UHMW-PE1200	绿色 Green

N05 Neck Guides

N05 宝特瓶风送条

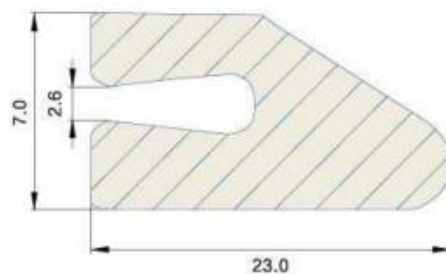

型号 Type	材质 Material	颜色 Color
N05	UHMW-PE450/PE1000	灰色 Grey

N06 Neck Guides

N06 宝特瓶风送条

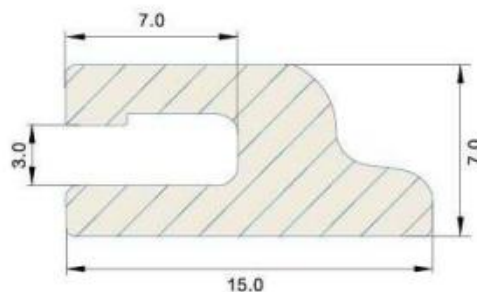

型号 Type	材质 Material	颜色 Color
N06	UHMW-PE450/PE1000	灰色 Grey

N07 Neck Guides

N07 宝特瓶风送条

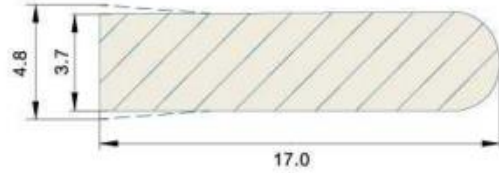

型号 Type	材质 Material	颜色 Color
N07	UHMW-PE450/PE1000	灰色 Grey

N08 Neck Guides

N08 宝特瓶风送条

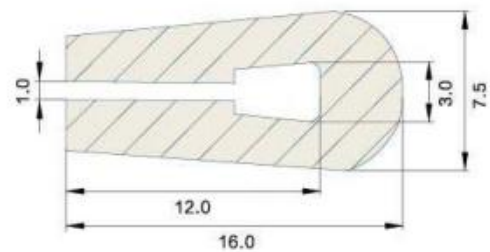

型号 Type	材质 Material	颜色 Color
N08	UHMW-PE450/PE1000	灰色 Grey

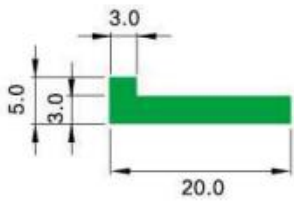

D501

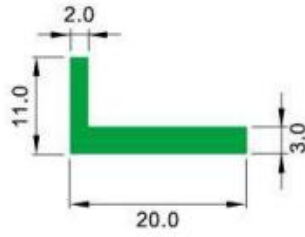

D502

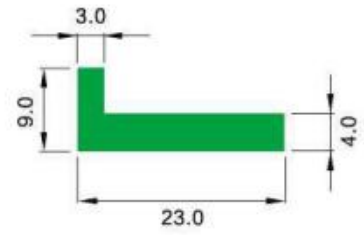

D503

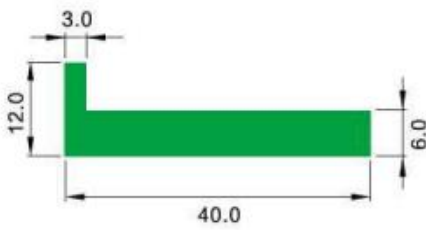

D504

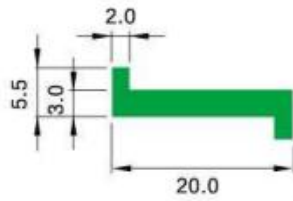

D505

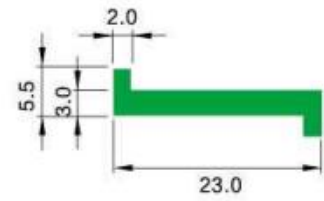

D506

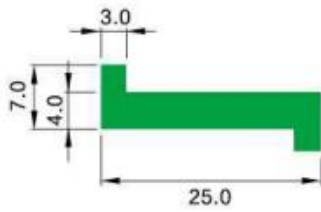

D507

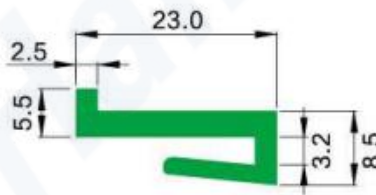

D508

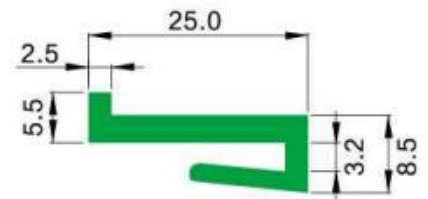

D509

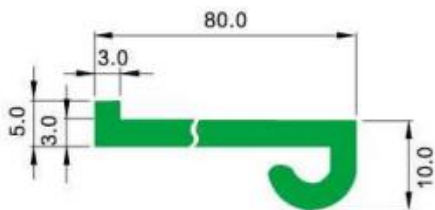

D510



D511

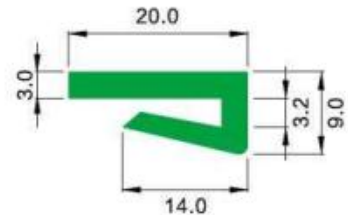

D512

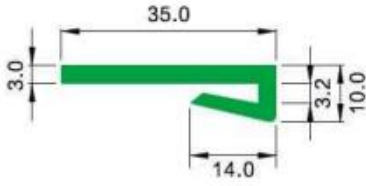

D513

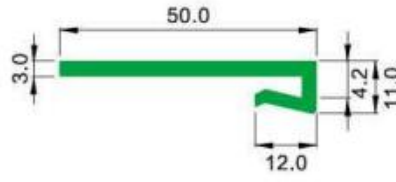

D514

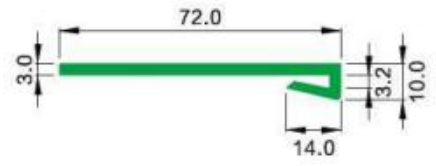

D515

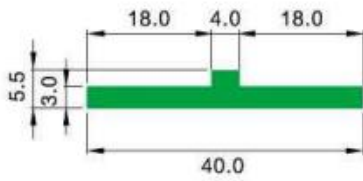

D516

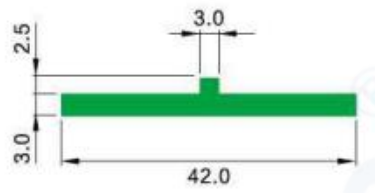

D517

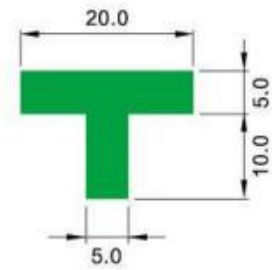

D518

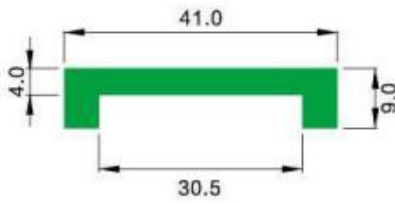

D519

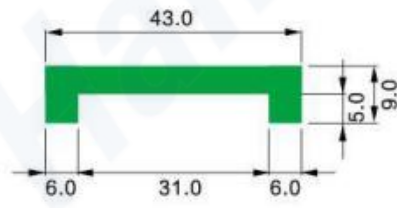

D520

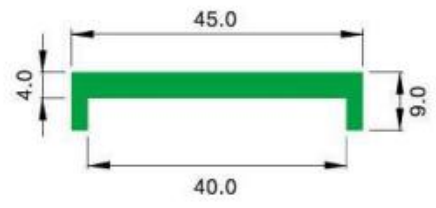

D521

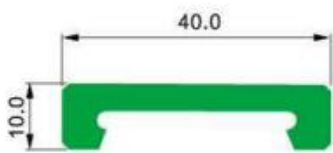

D522

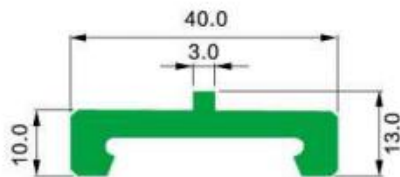

D523

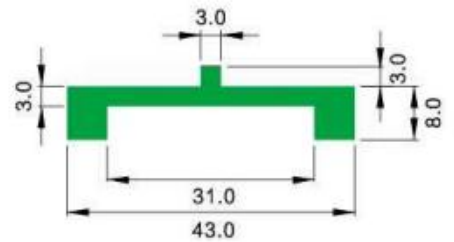

D524

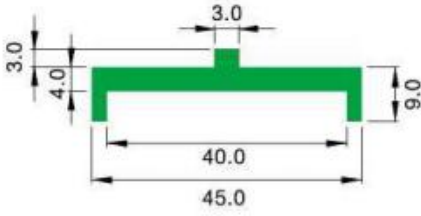

D525

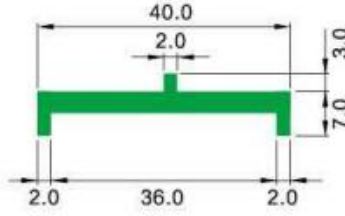

D526

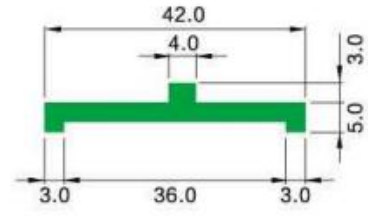

D527

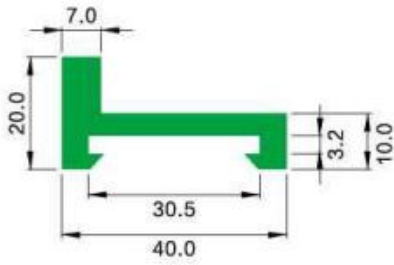

D528



D529

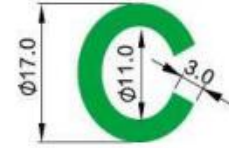

D530

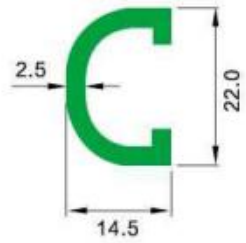

D531



D532

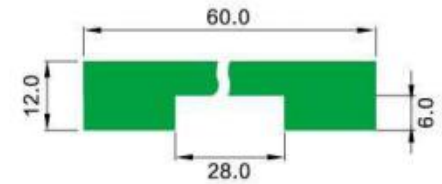

D533

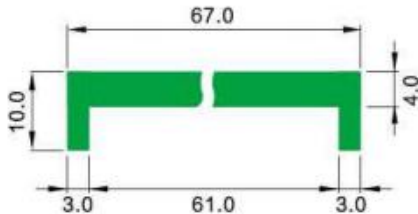

D534

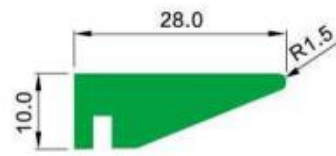

D535

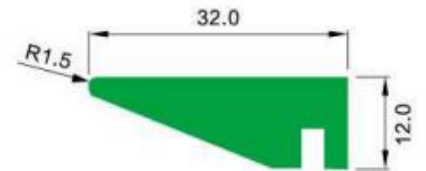

D536

W
配件 Accessories

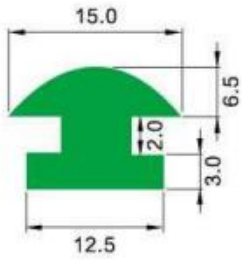

D537

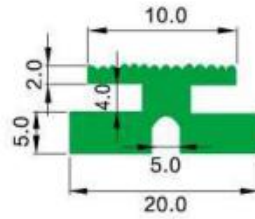

D538

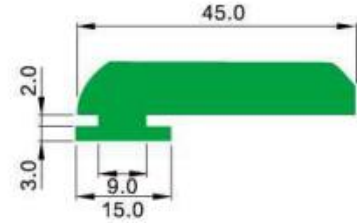

D539

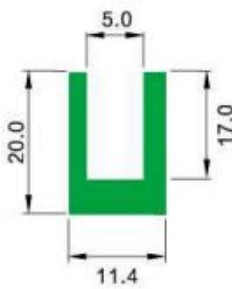

D540

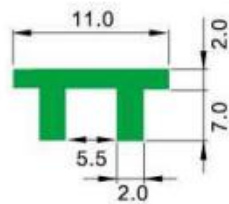

D541

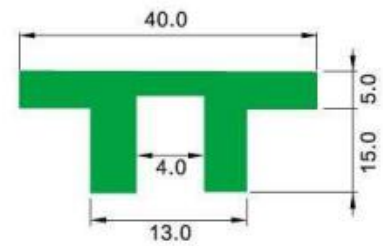

D542

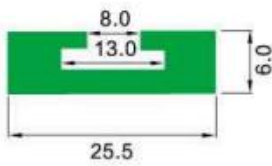

D543



D544

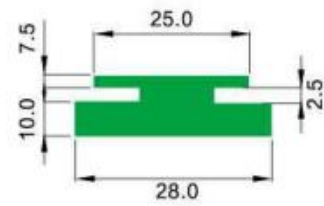

D545

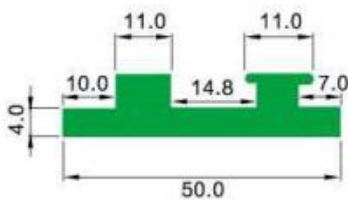

D546

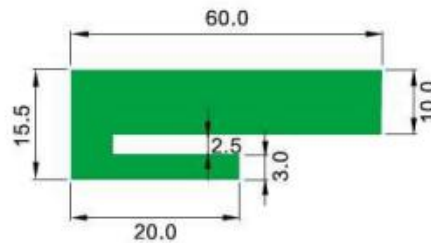

D547



W、T参数见W14页

D548

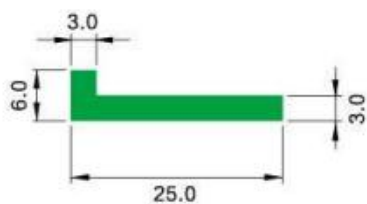

D549

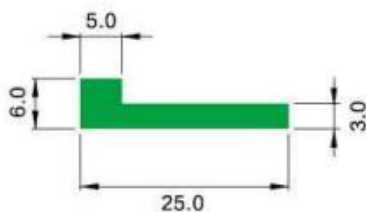

D550

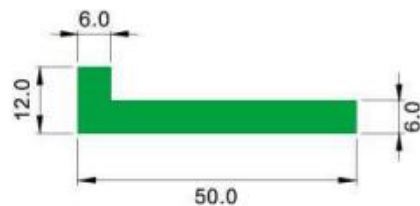

D551

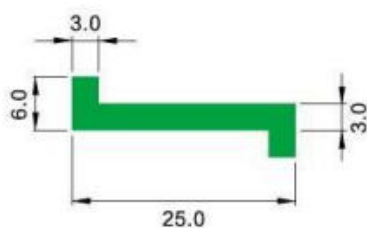

D552

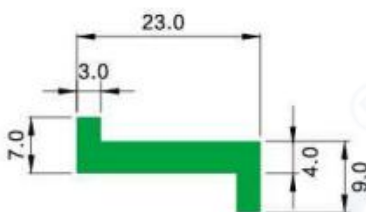

D553

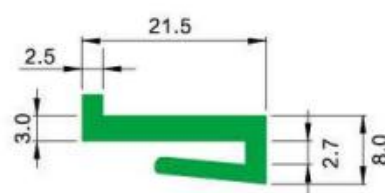

D554

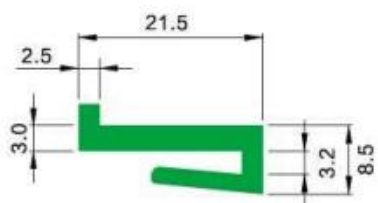

D555

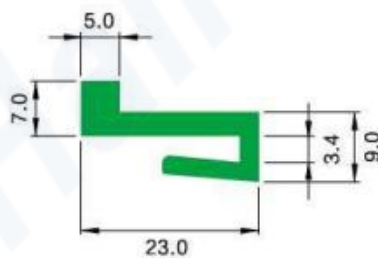

D556

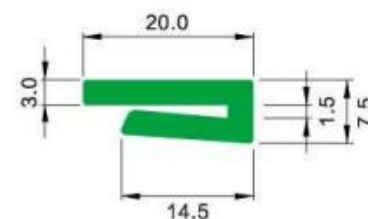

D557

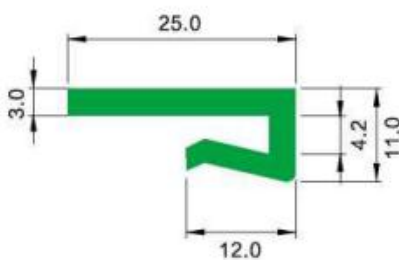

D558

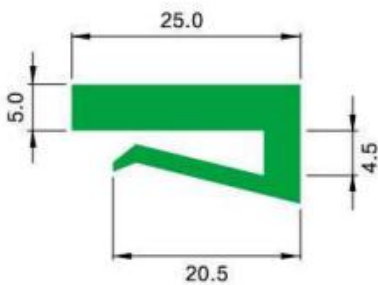

D559

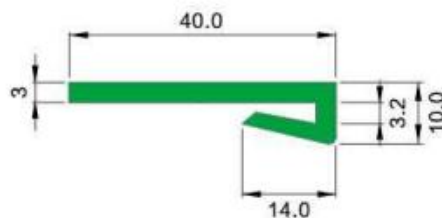

D560

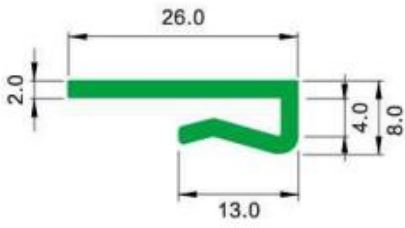

D561

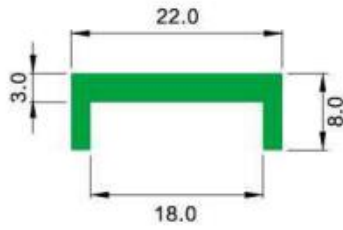

D562

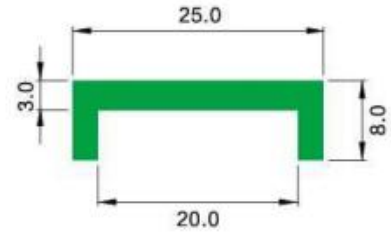

D563

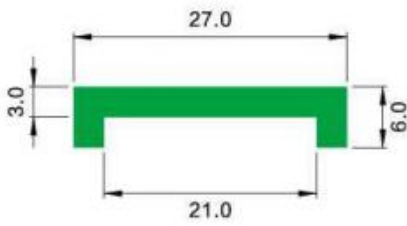

D564

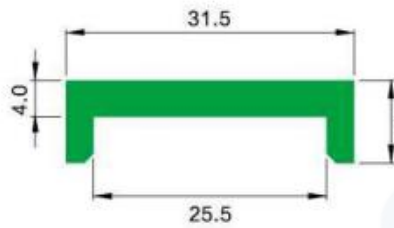

D565

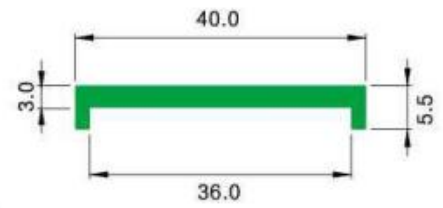

D566

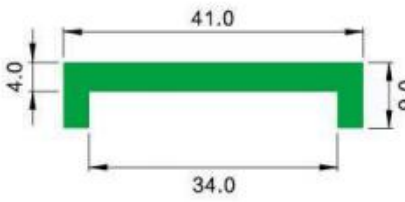

D567

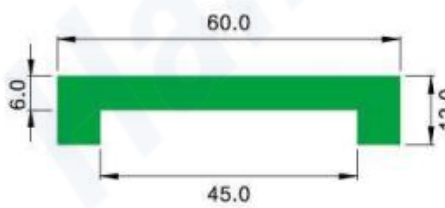

D568

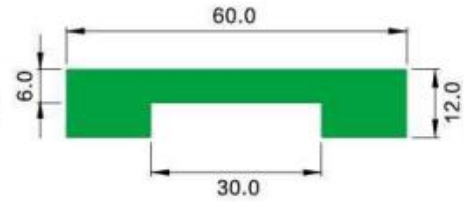

D569



D570

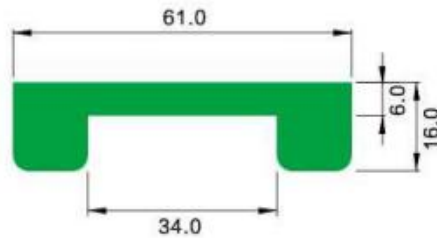

D580

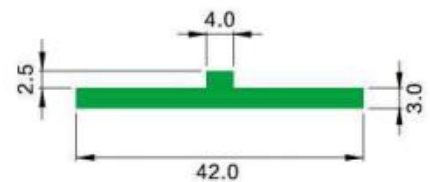

D581

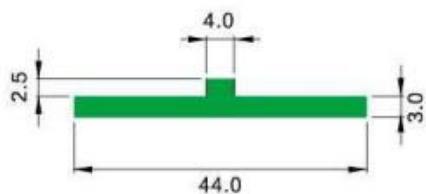

D582

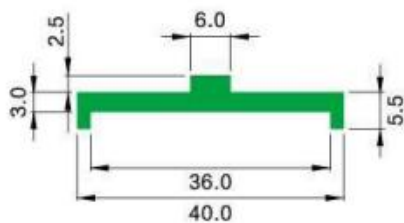

D583

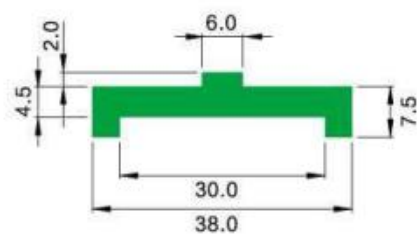

D584

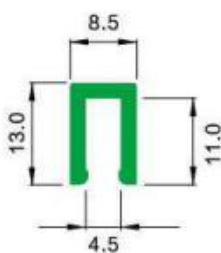

D585

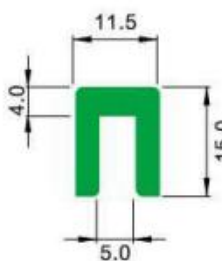

D586

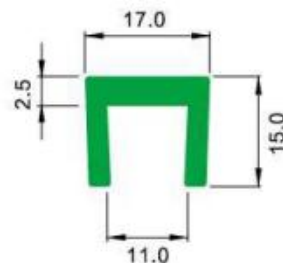

D587

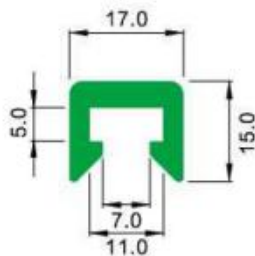

D588

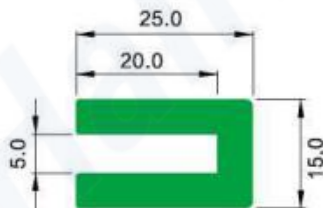

D589

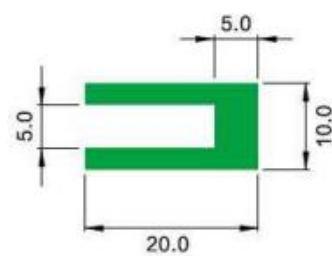

D590

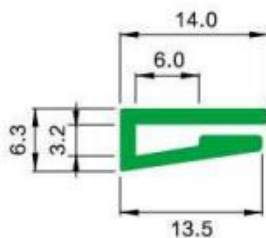

D591

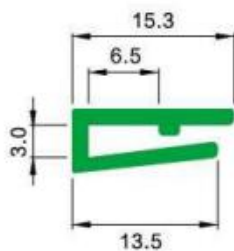

D592

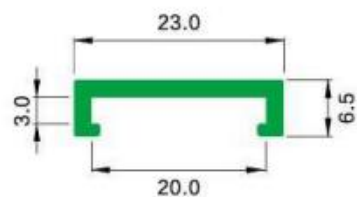

D593

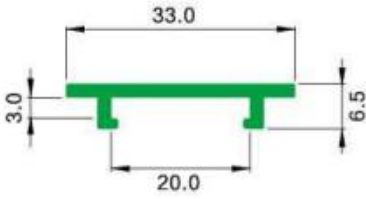

D594

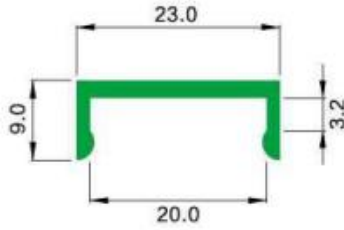

D595

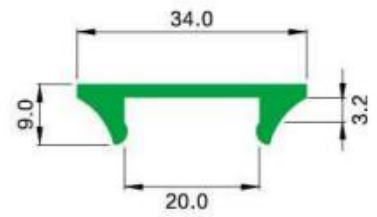

D596

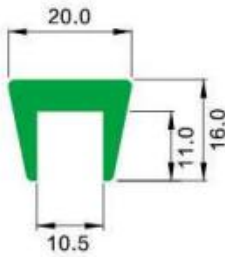

D597

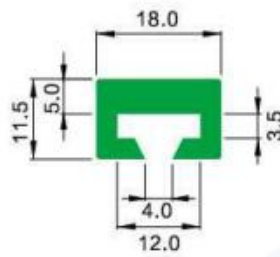

D598

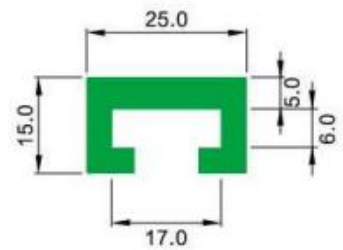

D599

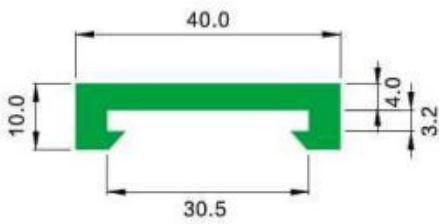

D600

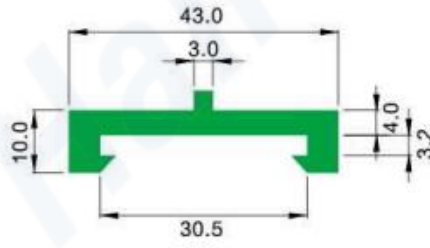

D601

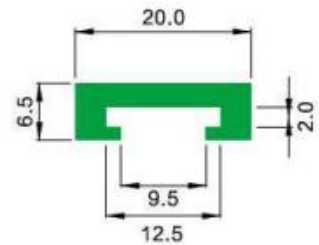

D602

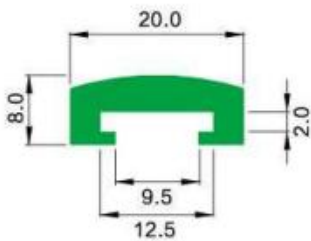

D603

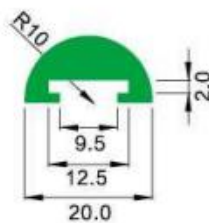

D604

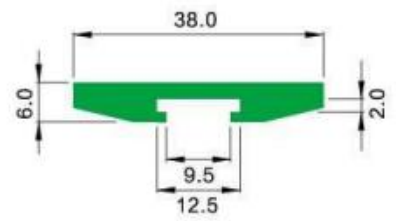

D605

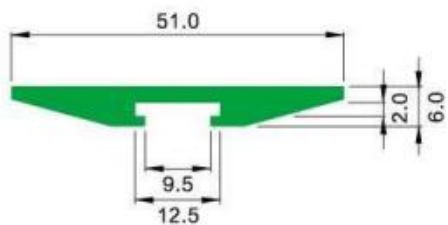

D606

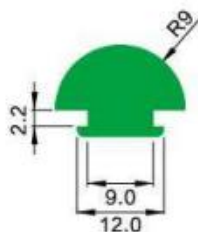

D607

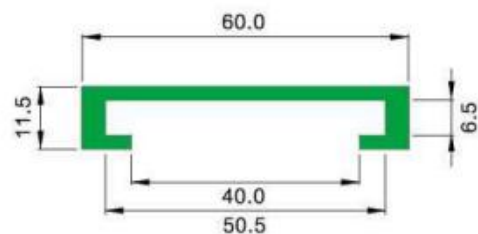

D608

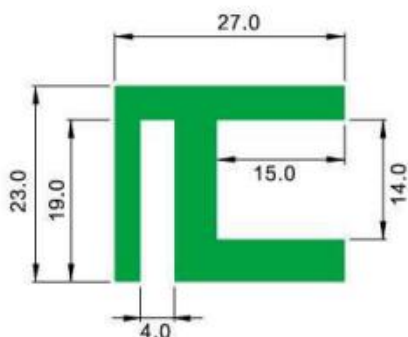

D609

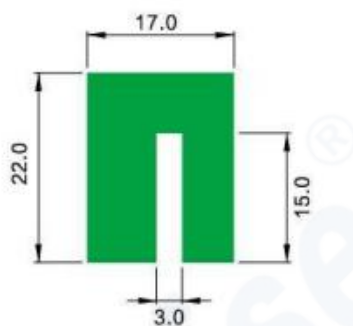

D610

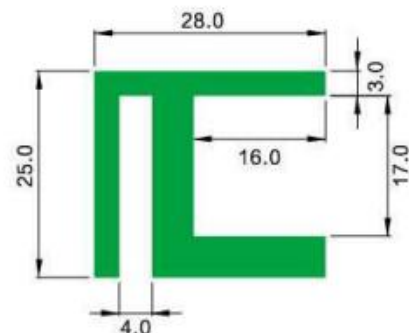

D611

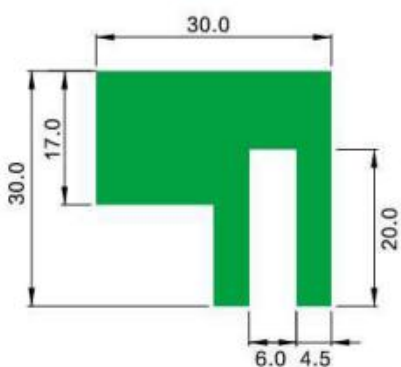

D612

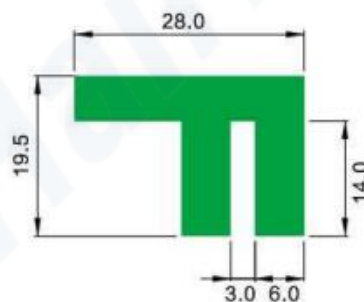

D613

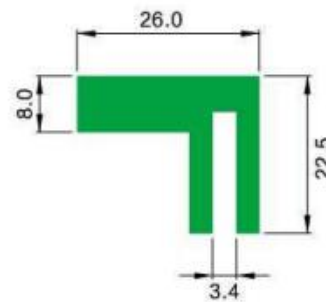

D614

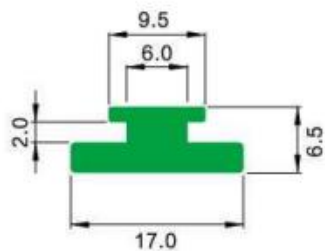

D615

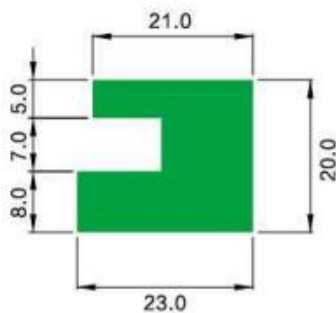

D616

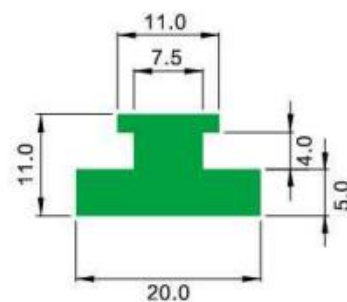

D617

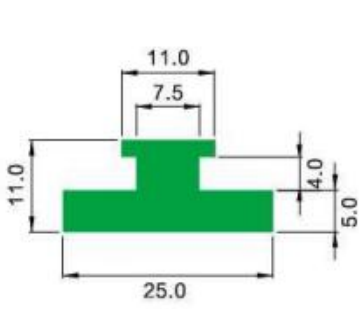

D618

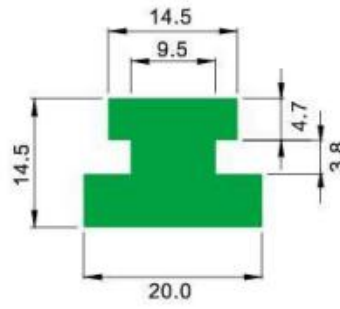

D619

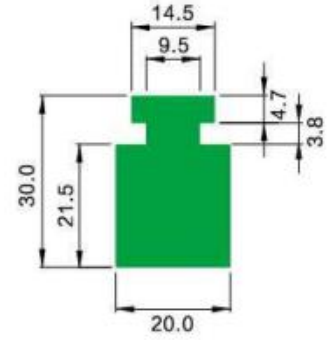

D620

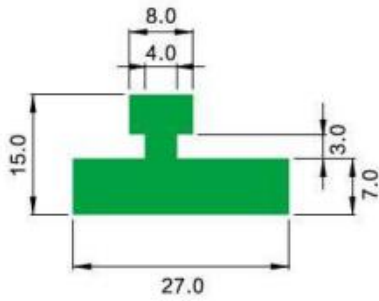

D621

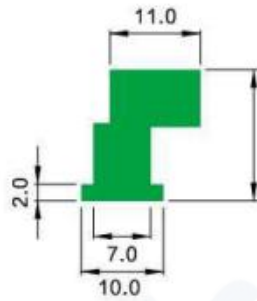

D622

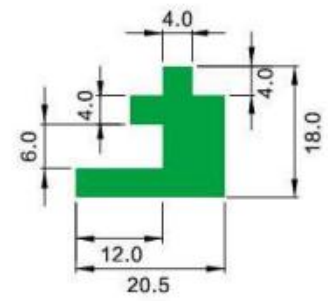

D623

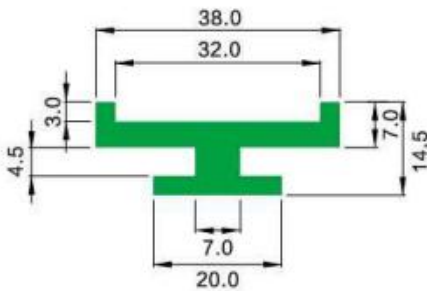

D624

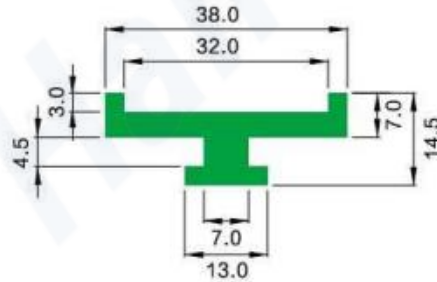

D625

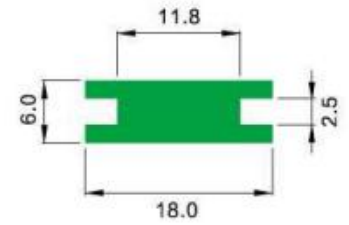

D626

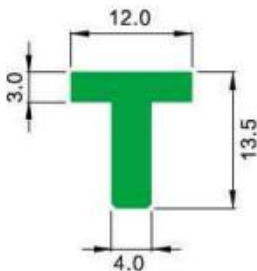

D627

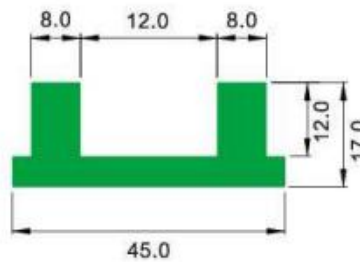

D628

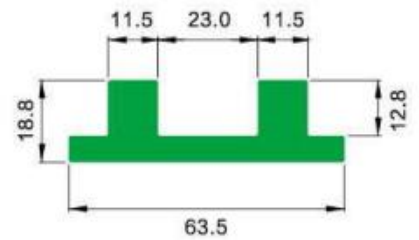

D629

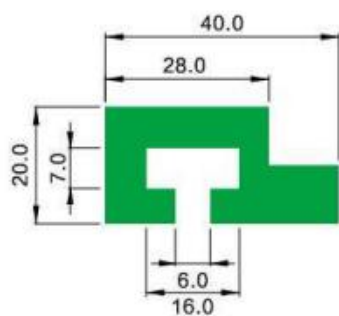

D630

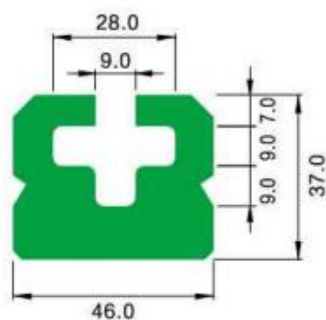

D631

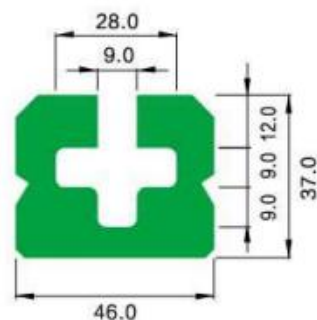

D632

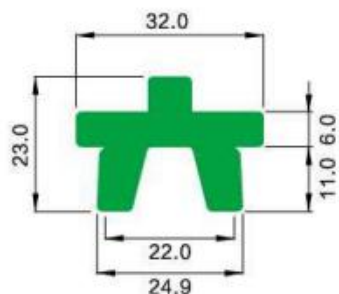

D633

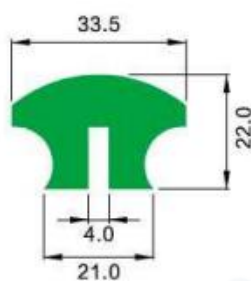

D634

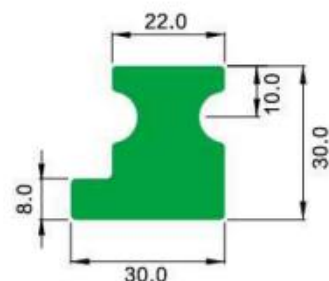

D635

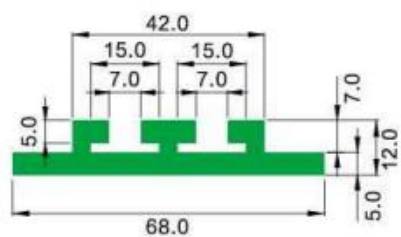

D636

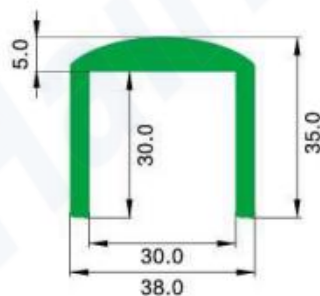

D637

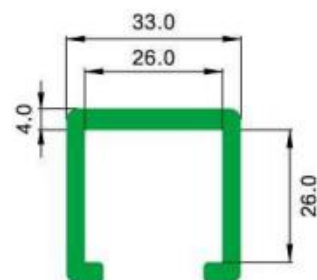

D638

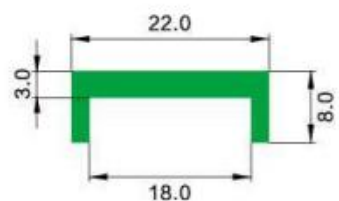

D639

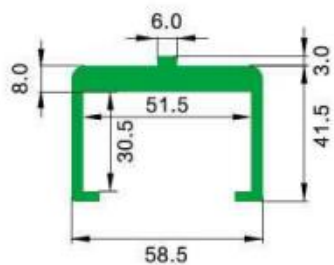

D640

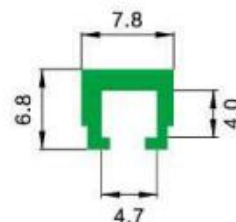

D641

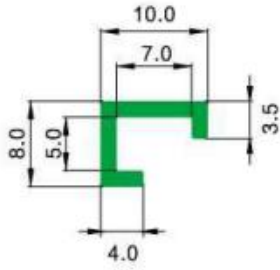

D642

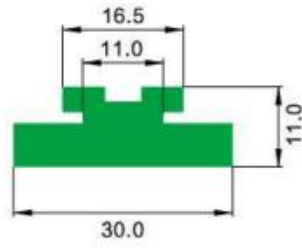

D643

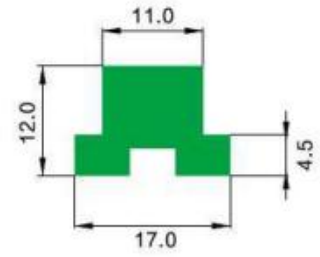

D644

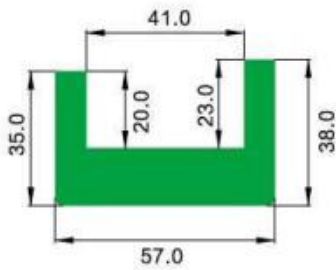

D645

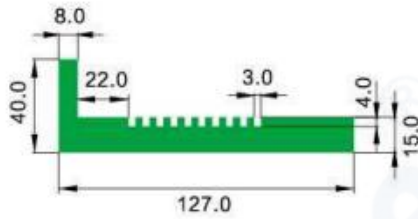

D646

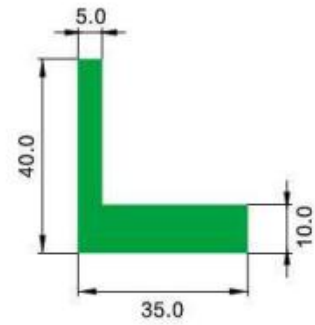

D647

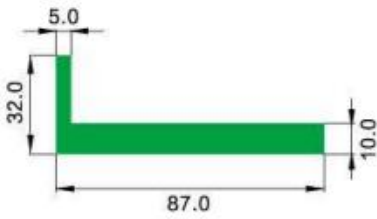

D648

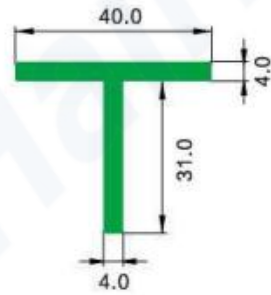

D649

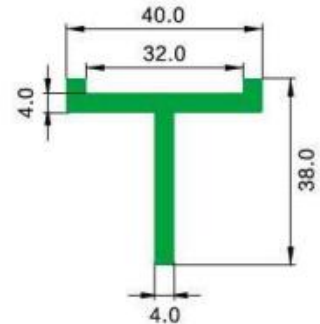

D650

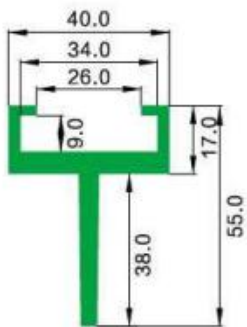

D651

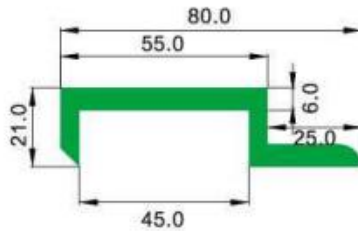

D652

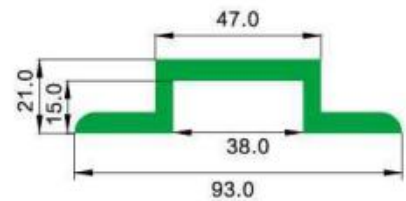

D653

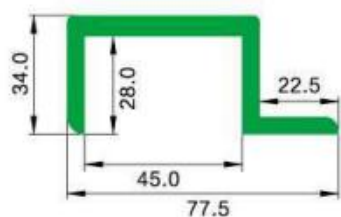

D654

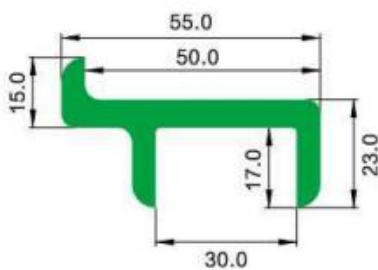

D655

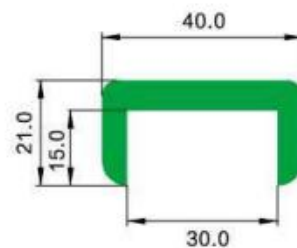

D656

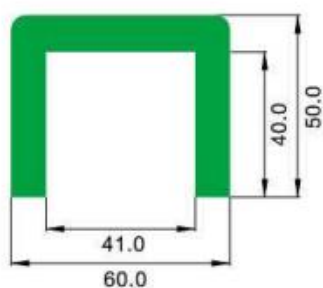

D657

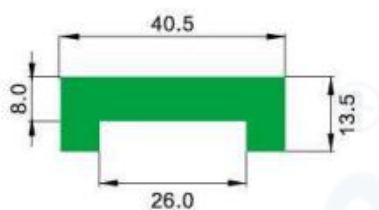

D658

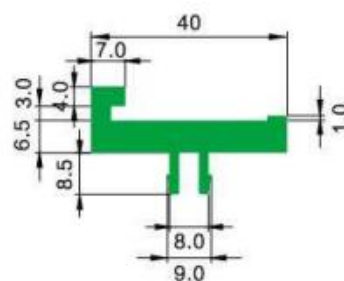

D659

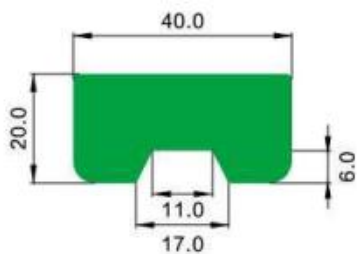

D660

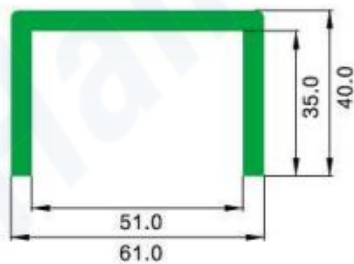

D661

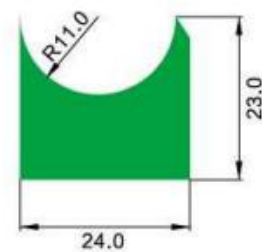

D662

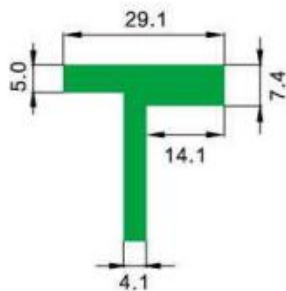

D663

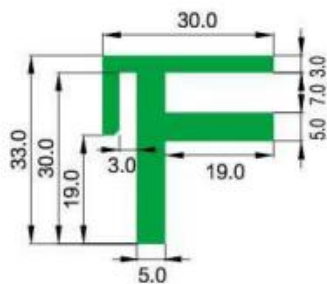

D664

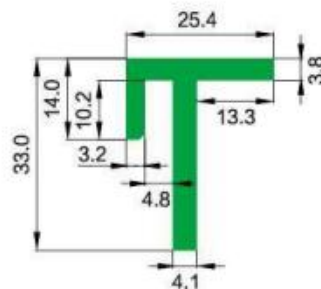

D665

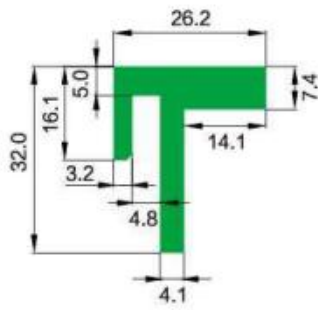

D666

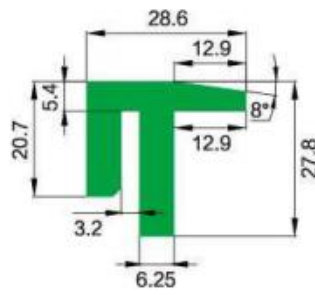

D667

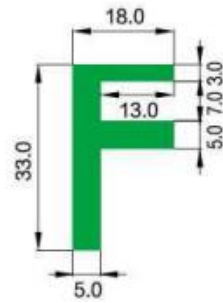

D668

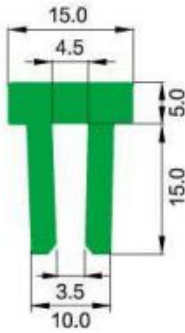

D669

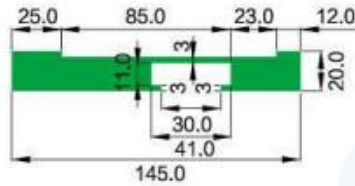

D670

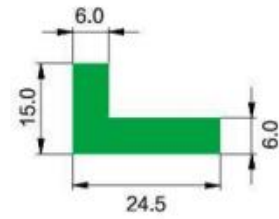

D671

D548参数

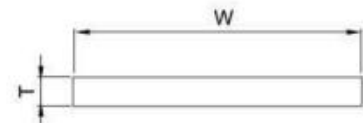

规格Size											
W (mm)	20	20	20	25	25	25	30	30	30	35	35
T (mm)	3	4	5	6	8	10	35	5	6	6	7
W (mm)	35	35	40	40	40	40	40	42	45	50	50
T (mm)	8	10	3	4	6	8	10	3	6	3	5
W (mm)	50	55	55	60	70	70	80	90	100	100	110
T (mm)	6	5	6	5	5	6	10	6	3	4	3

HarP701 Series Bracket

HarP701型小支架

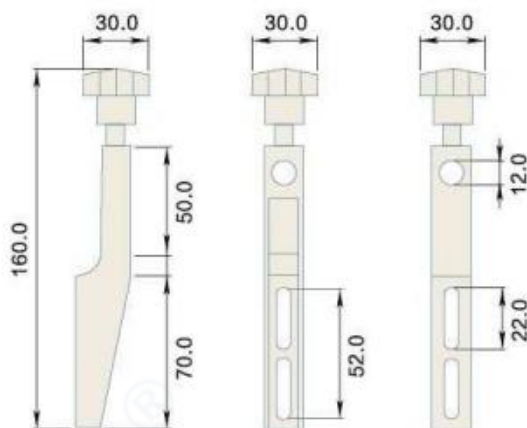

型号 Type	材质 Material	重量 Weight
HarP701	Nylon	60g

HarP702 Series Bracket

HarP702型转头支架

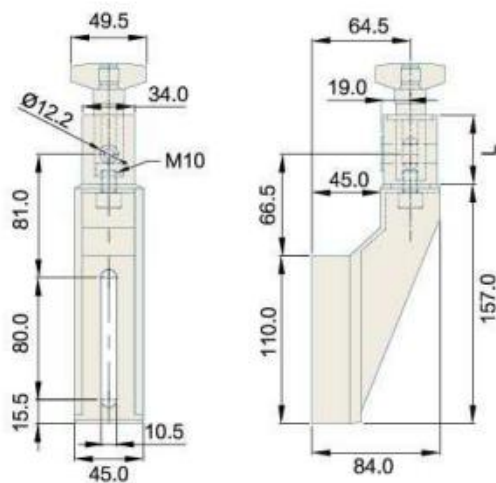

型号 Type	材质 Material	重量 Weight
HarP702	Nylon	260g

HarP703 Series Bracket

HarP703型插片支架

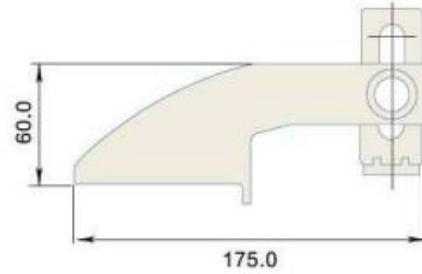

型号 Type	材质 Material	重量 Weight
HarP703	Nylon	173g

HarP704 Series Bracket

HarP704型大支架

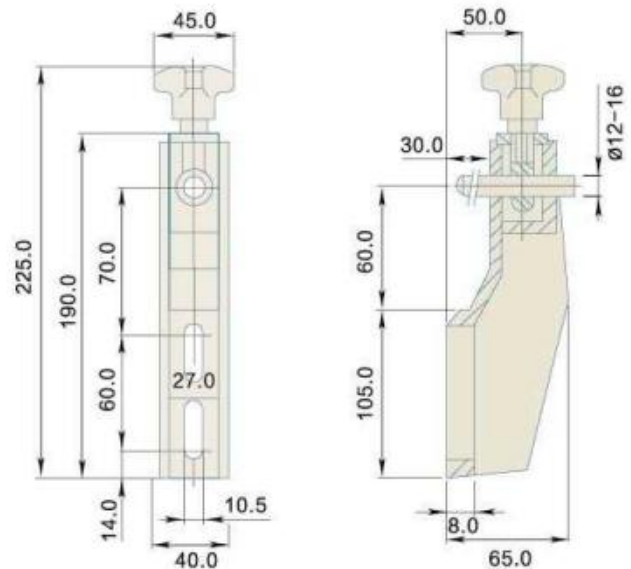

型号 Type	材质 Material	重量 Weight
HarP704	Nylon	185g

HarP705 Series Bracket

HarP705型支架

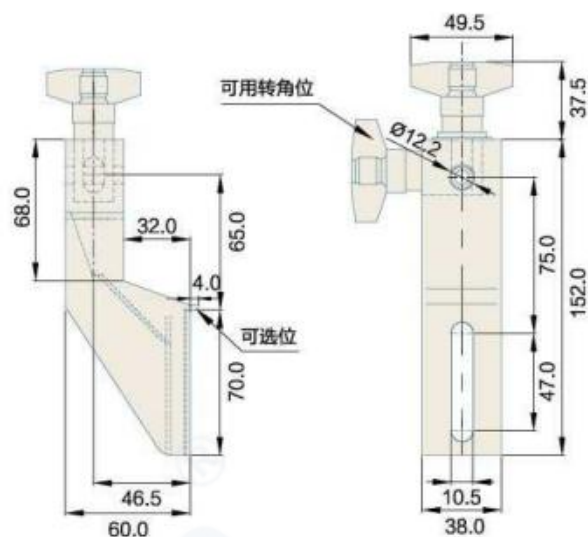

型号 Type	材质 Material	重量 Weight
HarP705	Nylon	190g

HarP706 Series Clamp For Sensors

HarP706型光电源接头

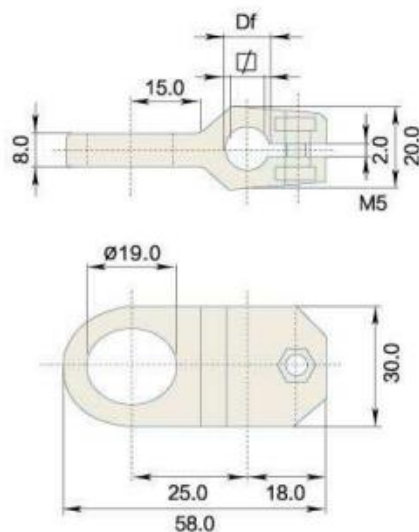

型号 Type	材质 Material	重量 Weight
HarP706	Nylon	20g

HarP707 Series Cross Clamp

HarP707型十字架

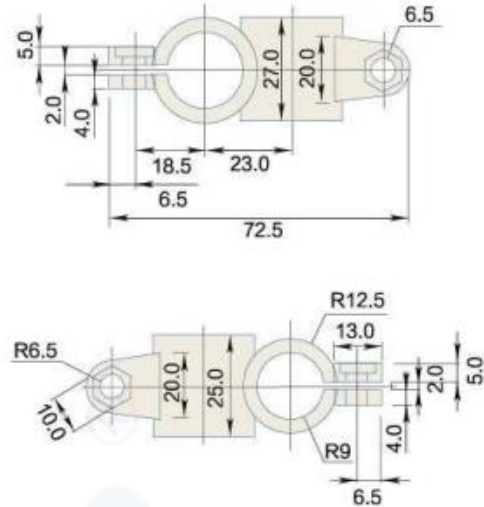

型号 Type	材质 Material	重量 Weight
HarP707	Nylon	30g

HarP708 Series Clamp For Bracket A

HarP708型光电源支架A

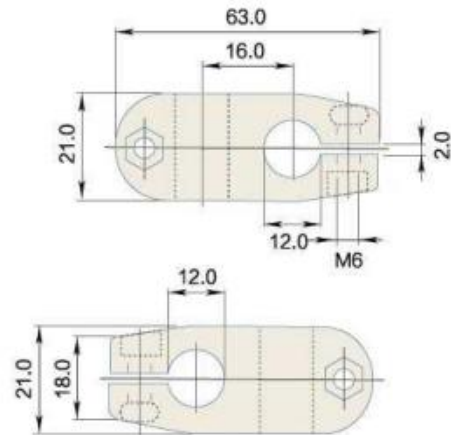

型号 Type	材质 Material	重量 Weight
HarP708	Nylon	30g

HarP709 Series Clamp For Bracket B

HarP709型光电源支架B

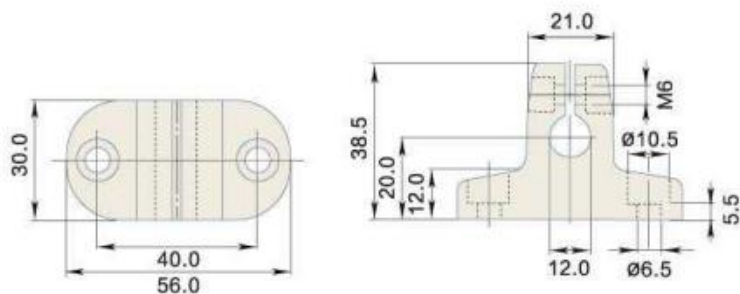

型号 Type	材质 Material	重量 Weight
HarP709	Nylon	30g

HarP710 Series Clamp For Bracket C

HarP710型光电源支架C

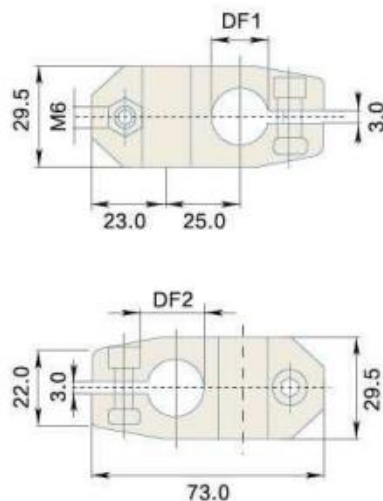

型号 Type	材质 Material	重量 Weight
HarP710	Nylon	60g

HarP711 Series Guide Rail Clamp A

HarP711型单夹A

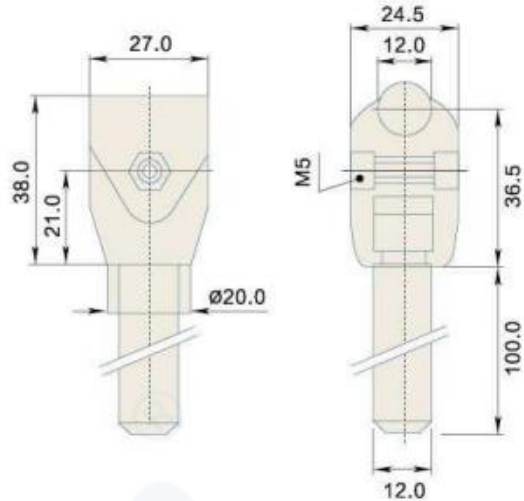

型号 Type	材质 Material	重量 Weight
HarP711	Nylon	125g

HarP712 Series Guide Rail Clamp B

HarP712型单夹B

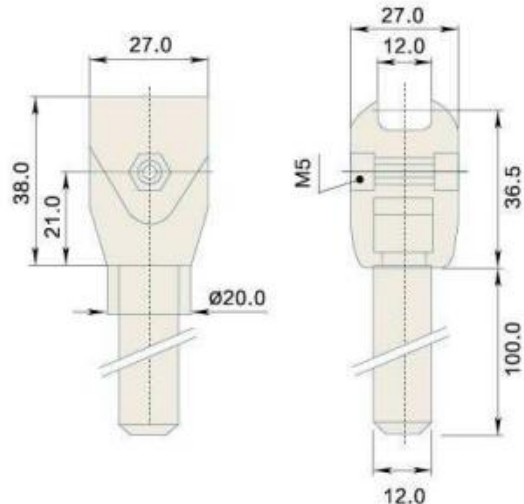

型号 Type	材质 Material	重量 Weight
HarP712	Nylon	125g

HarP713 Series Guide Rail Clamp

HarP713型方夹

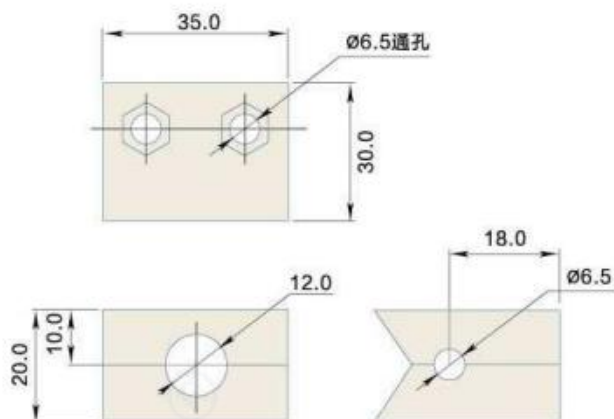

型号 Type	材质 Material	重量 Weight
HarP713	Nylon	42g

HarP714 Series Bracket

HarP714型可调单夹A

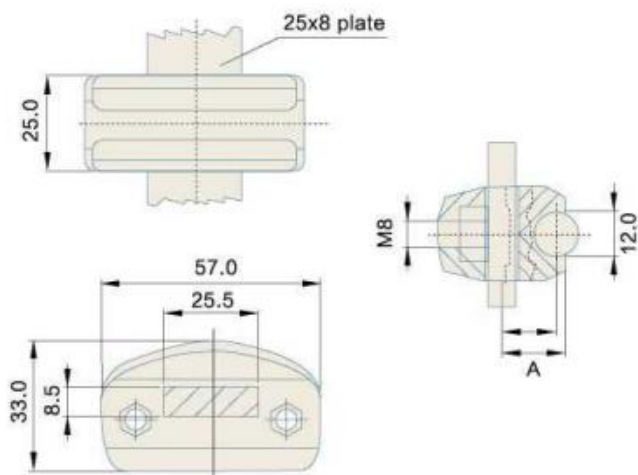

型号 Type	材质 Material	重量 Weight
HarP714	Nylon	51g

HarP715 Series Bracket

HarP715型可调单夹B

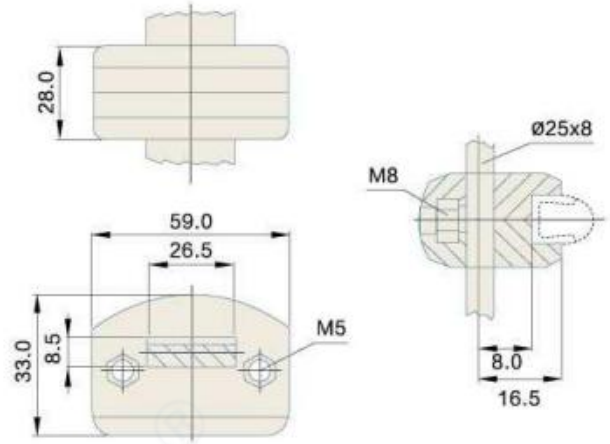

型号 Type	材质 Material	重量 Weight
HarP715	Nylon	50g

HarP716 Series Bracket

HarP716型双夹A

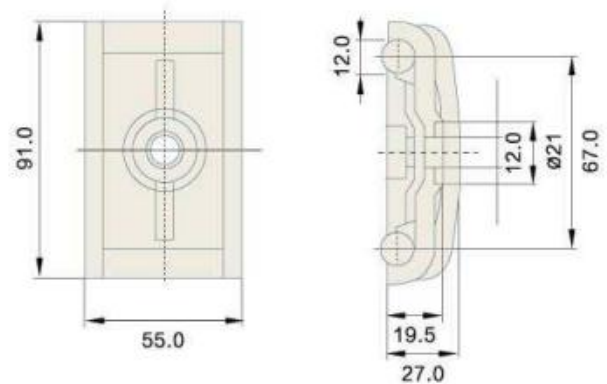

型号 Type	材质 Material	重量 Weight
HarP716	Nylon	185g

HarP717 Series Bracket

HarP717型双夹C

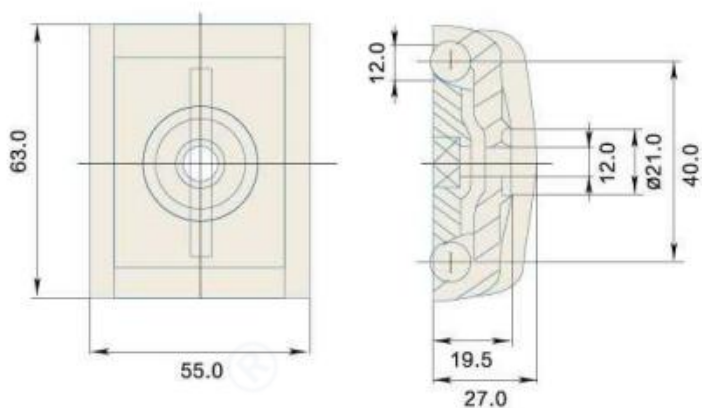

型号 Type	材质 Material	重量 Weight
HarP717	Nylon	150g

HarP718 Series Pulley

HarP718型托轮C

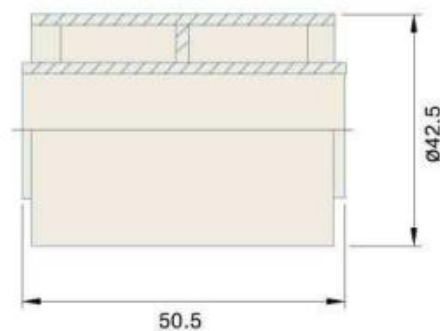

型号 Type	材质 Material	重量 Weight
HarP718	PP	30g

备注: 孔径 Bore Diameter: 20.5mm

HarP719 Series Pulley

HarP719型托轮D

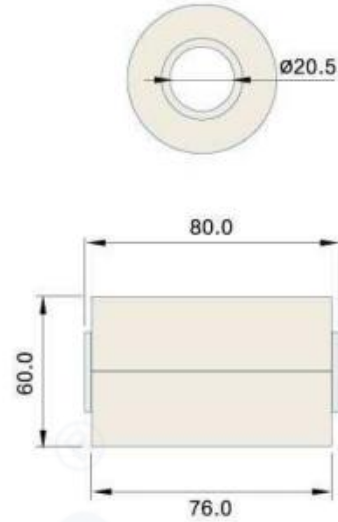

型号 Type	材质 Material	重量 Weight
HarP719	PE	90g

HarP720 Series Pulley

HarP720型托轮A

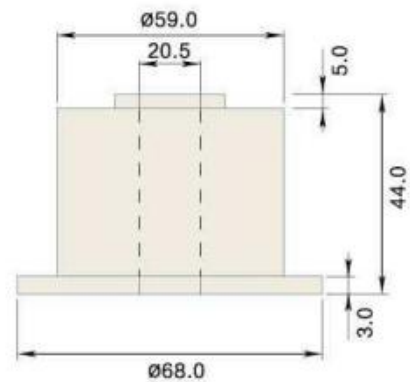

型号 Type	材质 Material	重量 Weight
HarP720	PP	18g

HarP721 Series Pulley

HarP721型拖轮B

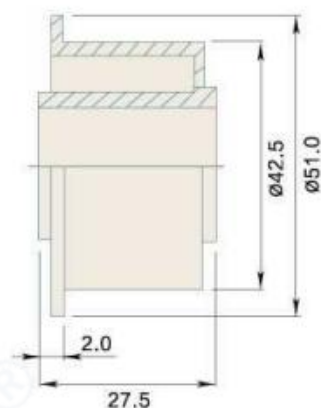

型号 Type	材质 Material	重量 Weight
HarP721	PP	10g

备注：孔径 Bore Diameter: 20.5mm

HarP722 Series Pulley

HarP722型拖轮C

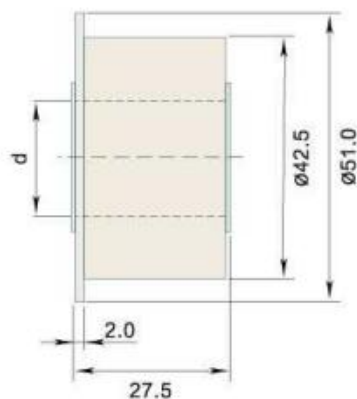

型号 Type	材质 Material	重量 Weight
HarP722	PP	10g

备注：孔径 Bore Diameter: 20.5mm

HarP723 Series Pulley

HarP723型拖轮D

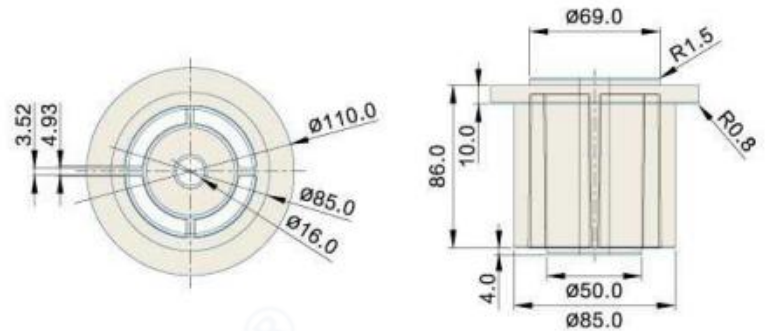

型号 Type	材质 Material	重量 Weight
HarP723	PP	320g

HarP724 Series Pulley

HarP724型大回路轮

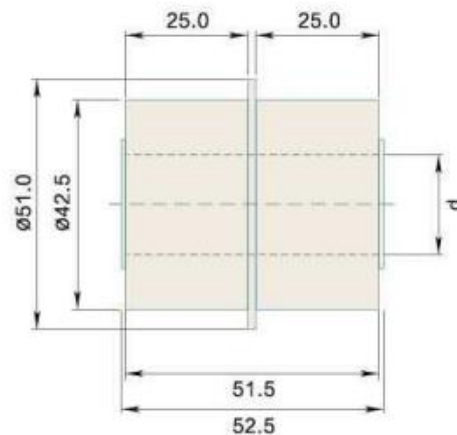

型号 Type	材质 Material	重量 Weight
HarP724	PP	20g

HarP725 Series Bracket

HarP725型托轮挡片

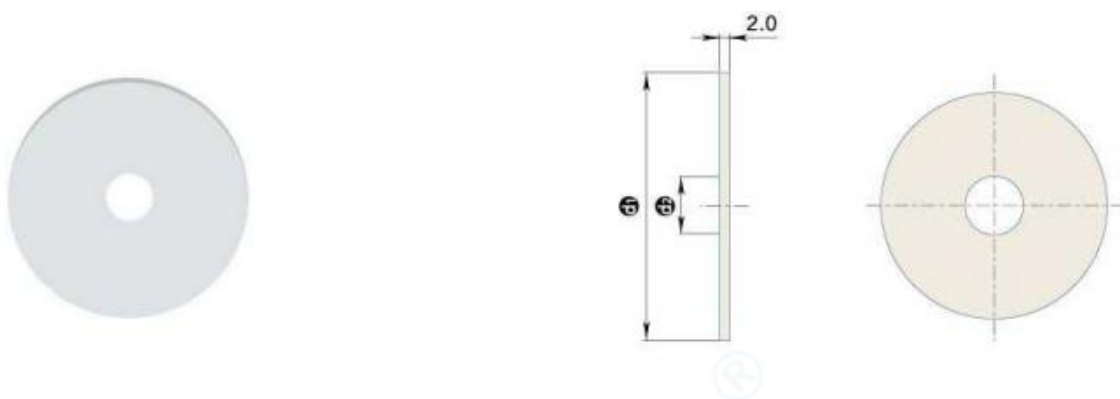

型号 Type	材质 Material	重量 Weight
HarP725	Nylon	10g

HarP725A Series Bracket Support

HarP725A型托块

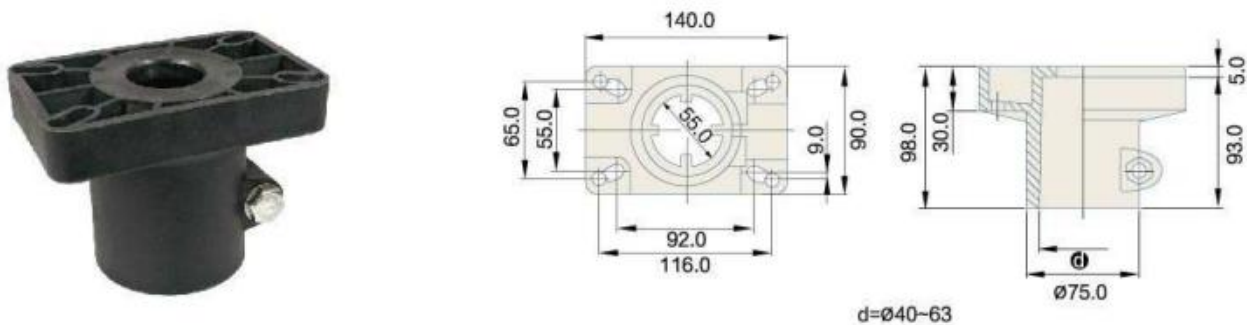

型号 Type	材质 Material	重量 Weight
HarP725A	Nylon	370g

HarP725B Series Bracket Support

HarP725B型托架

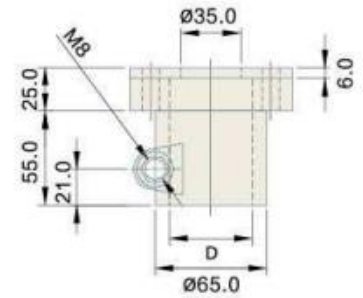
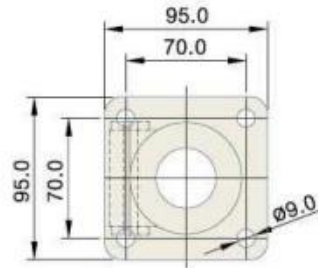

型号 Type	材质 Material	重量 Weight
HarP725B	Nylon	260g

HarP726 Series Bracket Support

HarP726型支脚三通

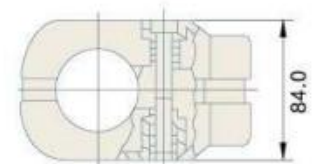
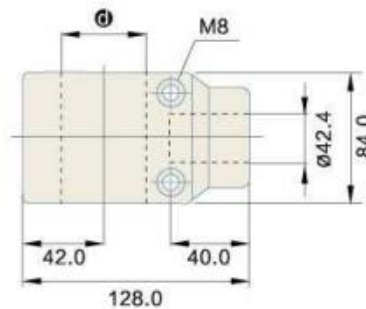

d=Ø48.3-60.3

型号 Type	材质 Material	重量 Weight
HarP726	Nylon	370g

HarP727 Series Side Mounting Top Bracket

HarP727型支撑座

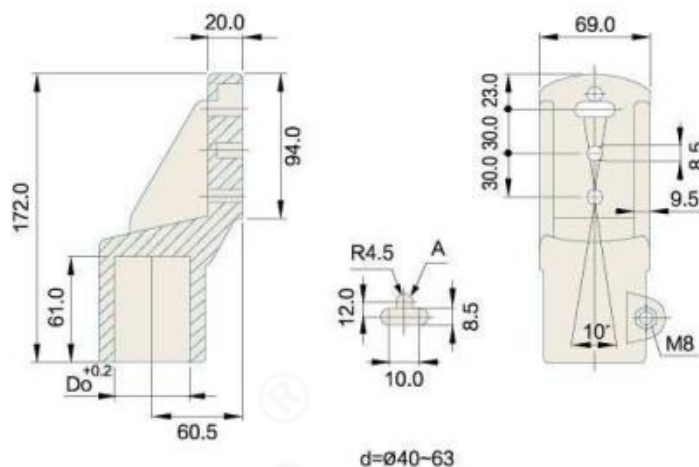

型号 Type	材质 Material	重量 Weight
HarP727	Nylon	250g

HarP728 Series Side Mounting Top Bracket

HarP728型支撑座

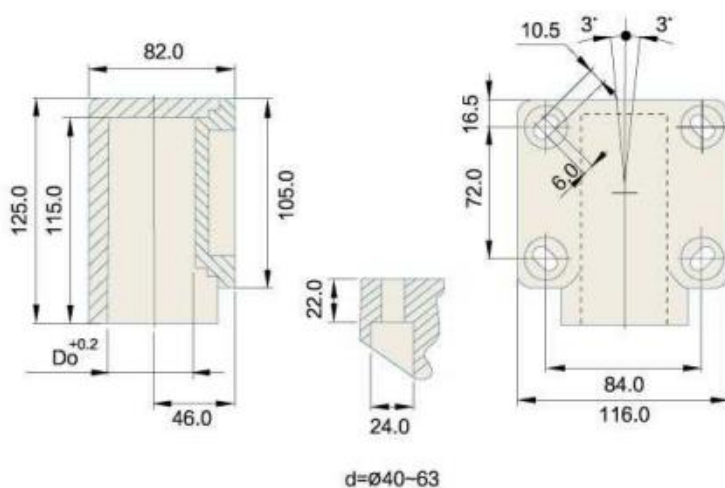

型号 Type	材质 Material	重量 Weight
HarP728	Nylon	150g

HarP729 Series Connect Part

HarP729型圆孔十字接头

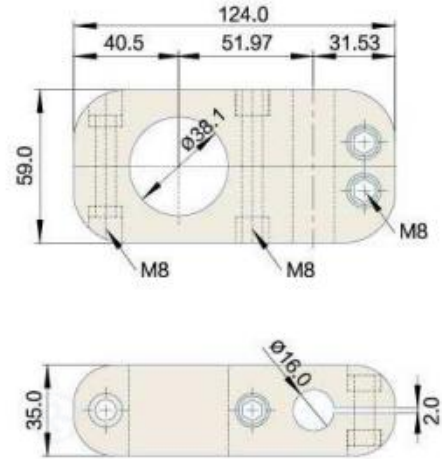

型号 Type	材质 Material	重量 Weight
HarP729	Nylon	70g

HarP730 Series Connect Part

HarP730型方孔十字接头

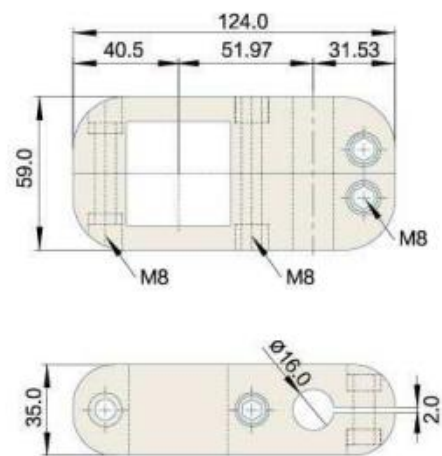

型号 Type	材质 Material	重量 Weight
HarP730	Nylon	75g

HarP731 Series Hinges

HarP731型中型活页

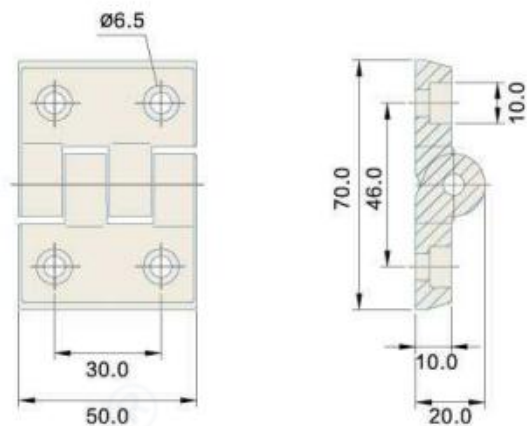

型号 Type	材质 Material	重量 Weight
HarP731	Nylon	50g

HarP732 Series Hinges

HarP732型大型活页

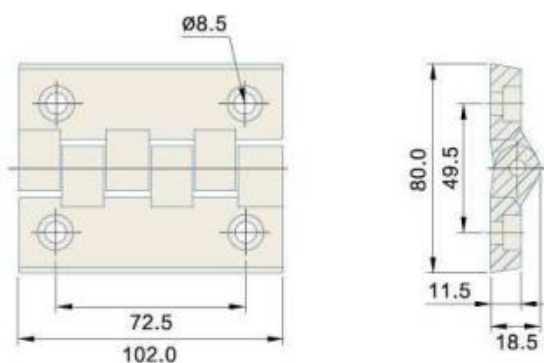

型号 Type	材质 Material	重量 Weight
HarP732	Nylon	80g

HarP733 Series Hinges

HarP733型小型活页(铝型材40×40专用)

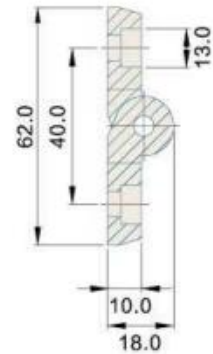
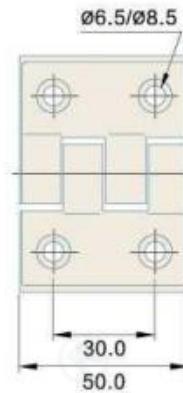

型号 Type	材质 Material	重量 Weight
HarP733	Nylon	30g

HarP734 Series Hinges

HarP734型小型活页

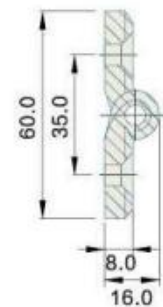
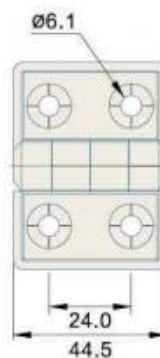

型号 Type	材质 Material	重量 Weight
HarP734	Nylon	20g

HarP735 Series Hinges

HarP735型特小型活页

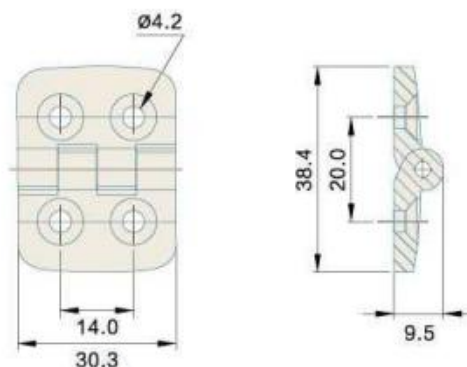

型号 Type	材质 Material	重量 Weight
HarP735	Nylon	10g

HarP736 Series Articulated Feet

HarP736型大底脚 $\varnothing 102$

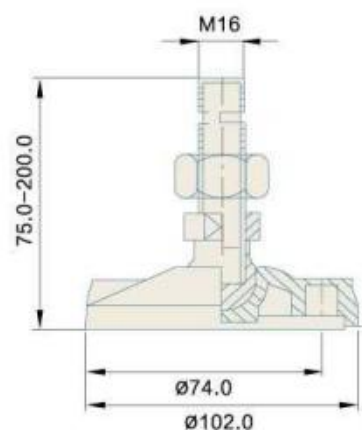

型号 Type	材质 Material	重量 Weight
HarP736	Nylon+SUS304	480g

HarP737 Series Articulated Feet

HarP737型关节底脚 $\varnothing 50$

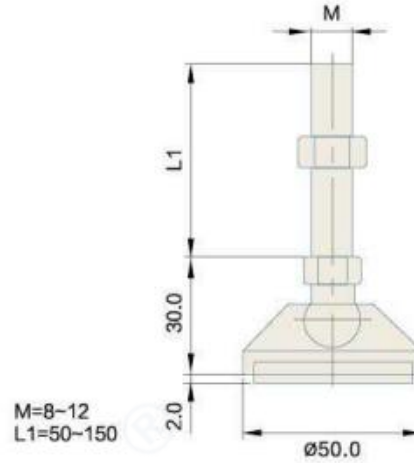

型号 Type	材质 Material	重量 Weight
HarP737	Nylon+SUS304	280g

HarP738 Series Articulated Feet

HarP738型关节底脚 $\varnothing 60$

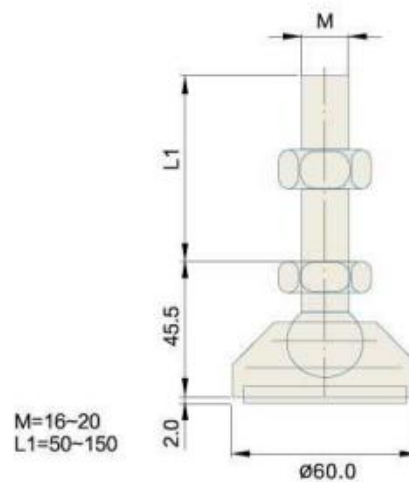

型号 Type	材质 Material	重量 Weight
HarP738	Nylon+SUS304	300g

HarP739 Series Articulated Feet

HarP739型关节底脚 $\varnothing 80$

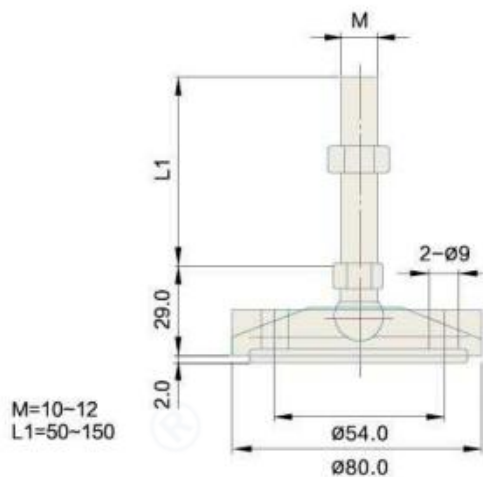

型号 Type	材质 Material	重量 Weight
HarP739	Nylon+SUS304	320g

HarP740 Series Articulated Feet

HarP740型关节底脚 $\varnothing 80$

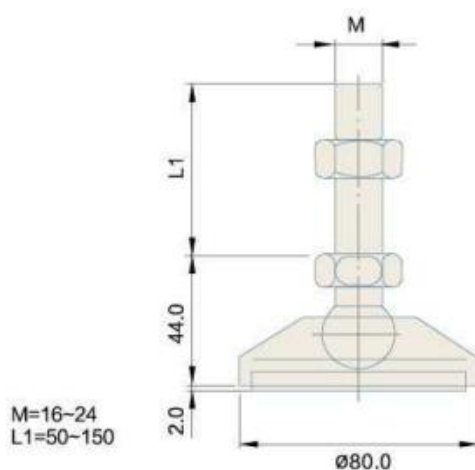

型号 Type	材质 Material	重量 Weight
HarP740	Nylon+SUS304	320g

HarP741 Series Articulated Feet

HarP741型关节底脚 $\varnothing 100$

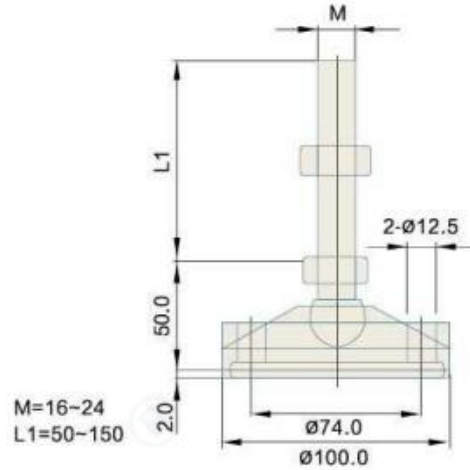

型号 Type	材质 Material	重量 Weight
HarP741	Nylon+SUS304	360g

HarP742 Series Articulated Feet

HarP742型小底脚 $\varnothing 80$

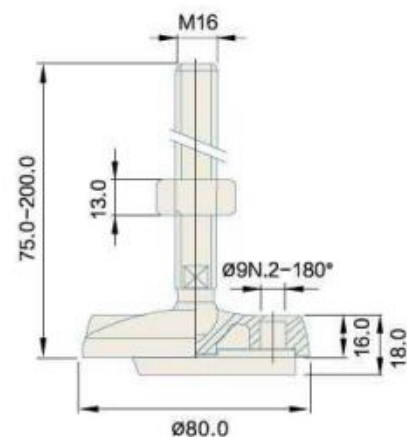

型号 Type	材质 Material	重量 Weight
HarP742	Nylon+SUS304	310g

HarP743 Series Articulated Feet

HarP743型底脚 $\varnothing 138$

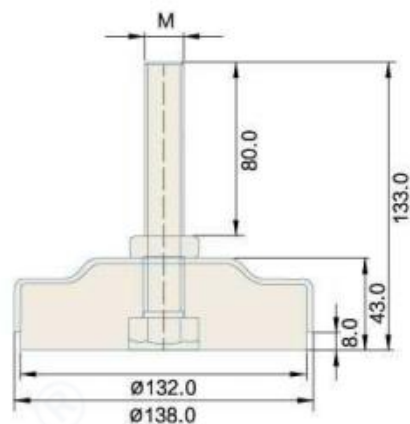

型号 Type	材质 Material	重量 Weight
HarP743	SUS 304	750g

HarP744 Series Handle

HarP744型中型把手

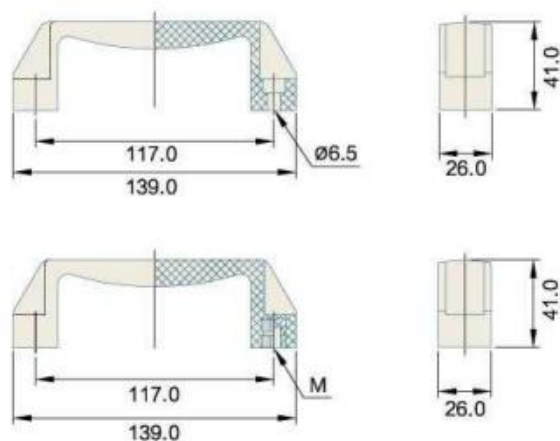

型号 Type	材质 Material	重量 Weight
HarP744	Nylon	55g

HarP745 Series Handle

HarP745型大型把手

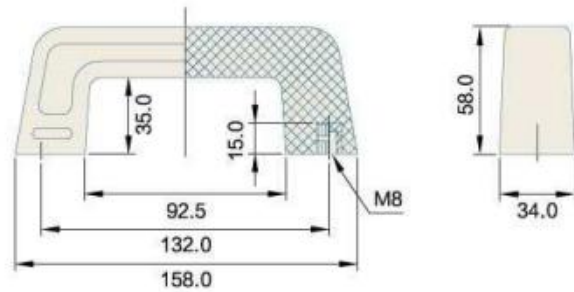

型号 Type	材质 Material	重量 Weight
HarP745	Nylon	130g

HarP746 Series Bolt

HarP746型插销

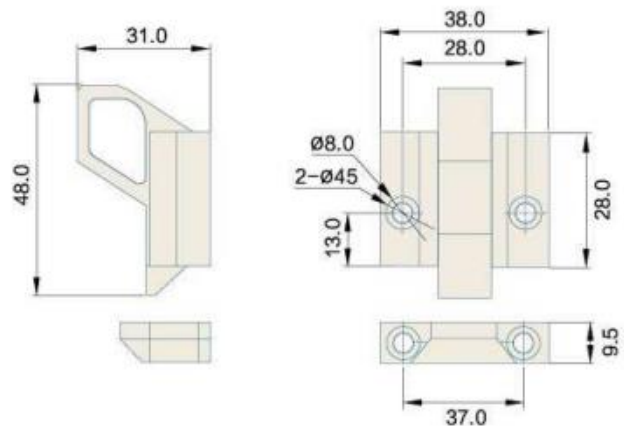

型号 Type	材质 Material	重量 Weight
HarP746	Nylon	68g

HarP747 Series Joint Part

HarP747型门框接头

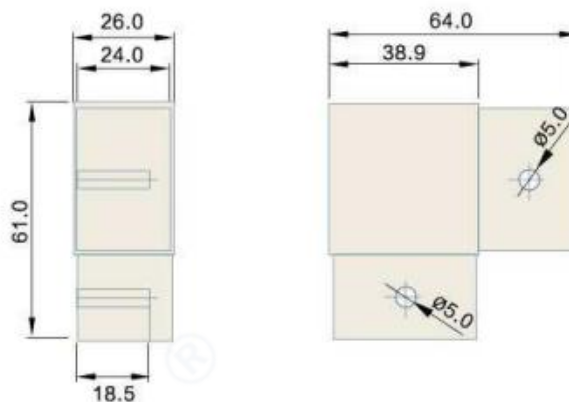

型号 Type	材质 Material	重量 Weight
HarP747	Nylon	68g

HarP748 Series Square Tube

HarP748型方管脚套

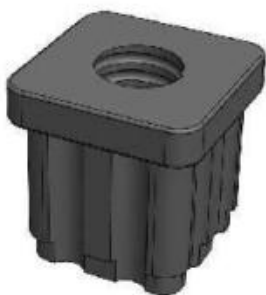

- ☐ 38X38
- ☐ 40X40
- ☐ 50X50

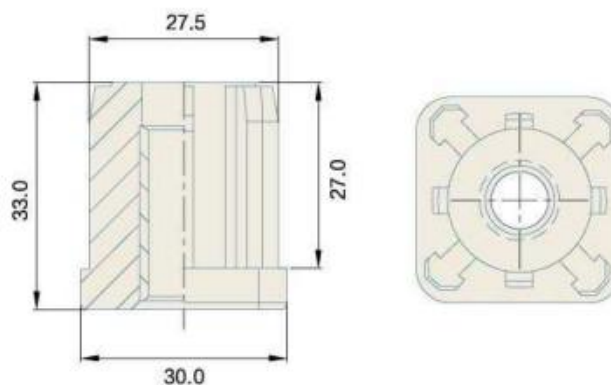

型号 Type	材质 Material	重量 Weight
HarP748	Nylon	68g

HarP749 Series Round Tube

HarP749型圆管脚套

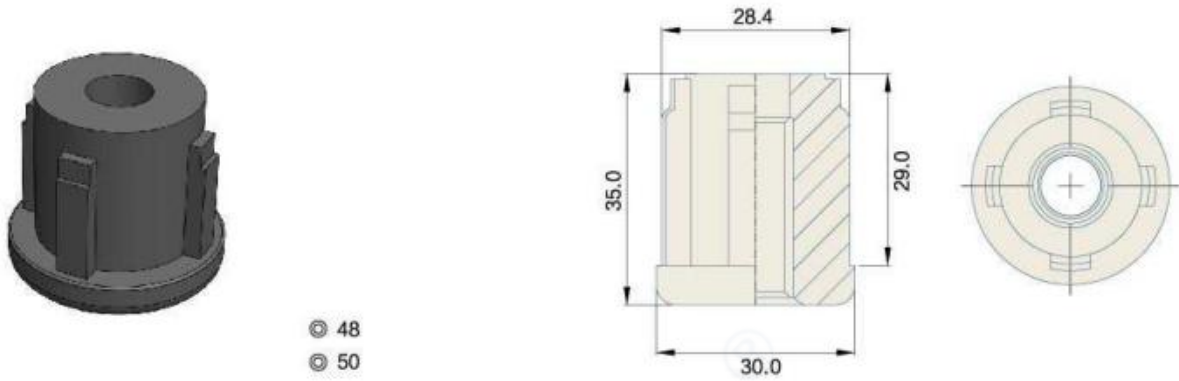

型号 Type	材质 Material	重量 Weight
HarP749	Nylon	68g

HarP750 Series Fix Handle

HarP750型固定扳手

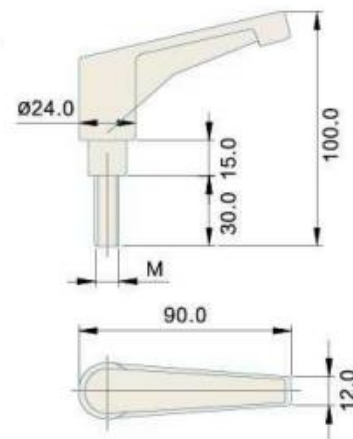

型号 Type	材质 Material	重量 Weight
HarP750	Nylon	68g

HarP751 Series Foot Pad

HarP751型垫脚A

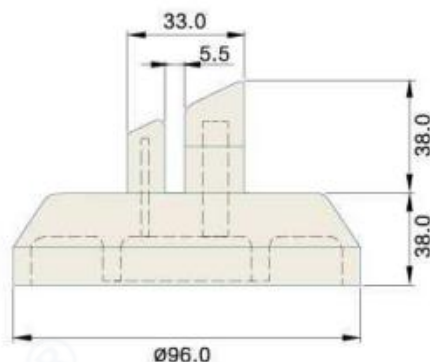

型号 Type	材质 Material	重量 Weight
HarP751	Nylon	68g

HarP752 Series Foot Pad

HarP752型垫脚B

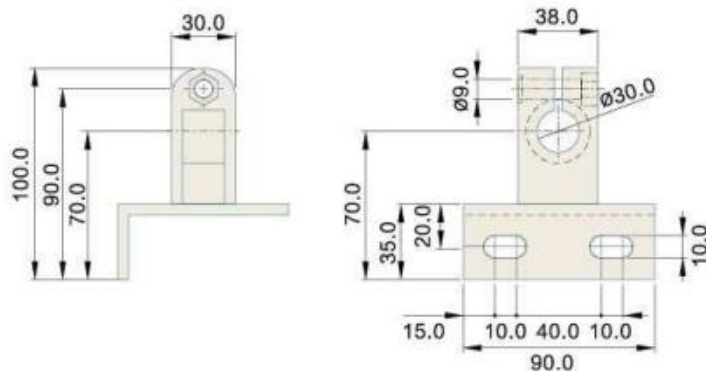

型号 Type	材质 Material	重量 Weight
HarP752	Nylon	68g

HarP753 Series Support Base

HarP753型二脚支架A

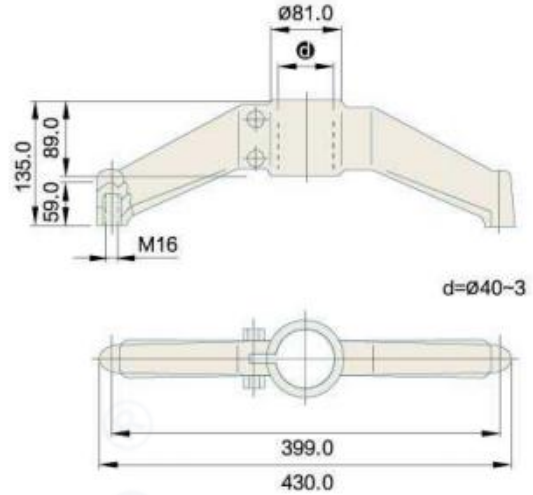

型号 Type	材质 Material	重量 Weight
HarP753	Nylon	860g

HarP754 Series Support Base

HarP754型二脚支架B

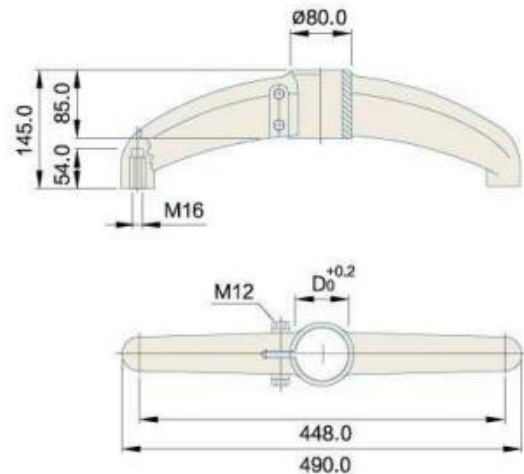

型号 Type	材质 Material	重量 Weight
HarP754	Nylon	800g

HarP755 Series Support Base

HarP755型二脚半支架C

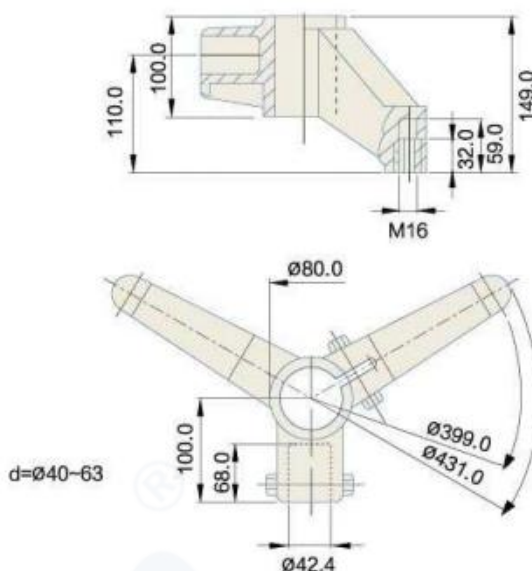

型号 Type	材质 Material	重量 Weight
HarP755	Nylon	1080g

HarP756 Series Support Base

HarP756型二脚半支架D

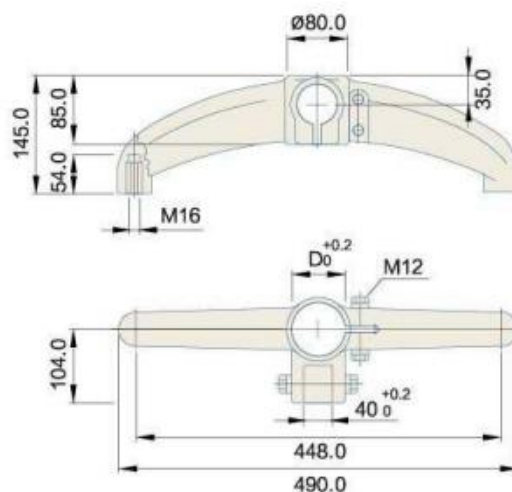

型号 Type	材质 Material	重量 Weight
HarP756	Nylon	1170g

HarP757 Series Squared Support Base

HarP757型方型三角底架

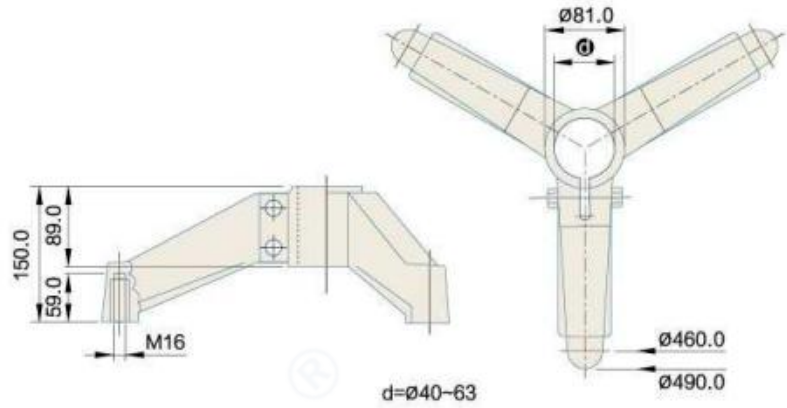

型号 Type	材质 Material	重量 Weight
HarP757	Nylon	1120g

HarP758 Series Round Support Base

HarP758型圆弧型三角底架

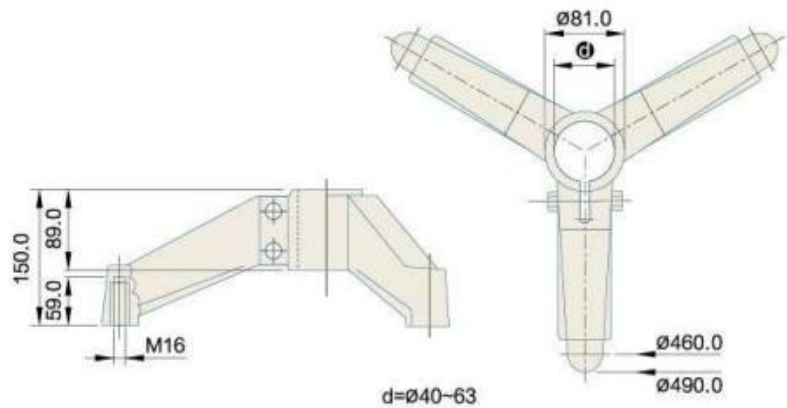

型号 Type	材质 Material	重量 Weight
HarP758	Nylon	1200g

HarP759 Series Connected Part

HarP759型平铺接头A

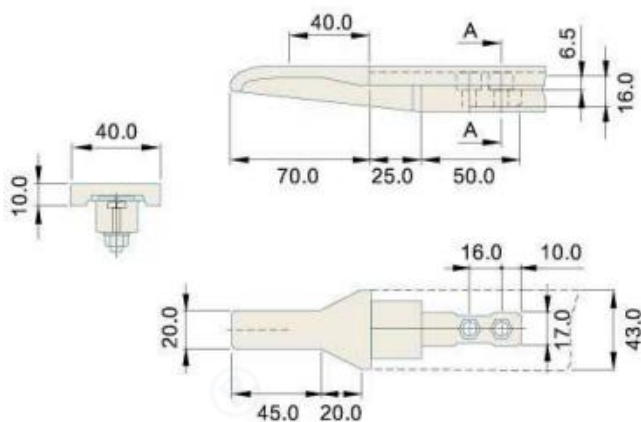

型号 Type	材质 Material	重量 Weight
HarP759	Nylon	60g

HarP760 Series Connected Part

HarP760型平铺接头B

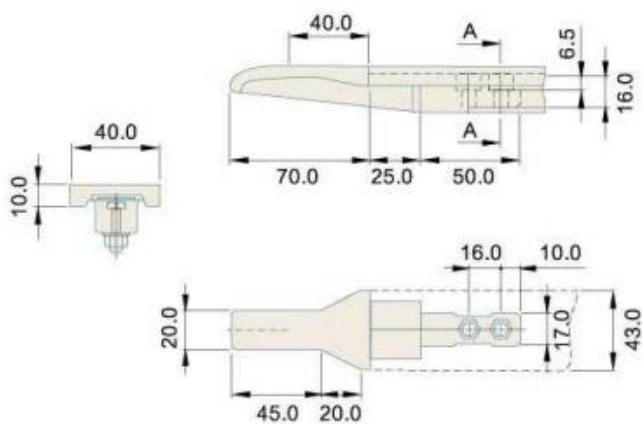

型号 Type	材质 Material	重量 Weight
HarP760	Nylon	60g

HarP761 Series Support Shaft

HarP761型支撑轴A

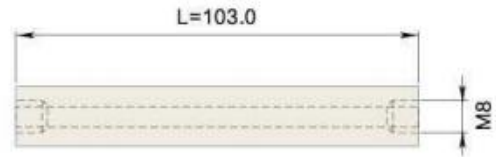

型号 Type	材质 Material	重量 Weight
HarP761	Nylon	46g

HarP762 Series Support Shaft

HarP762型支撑轴B

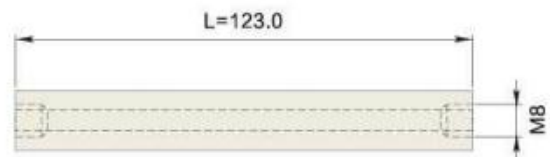

型号 Type	材质 Material	重量 Weight
HarP762	Nylon	56g

HarP763 Series Component

HarP763型导向叉A

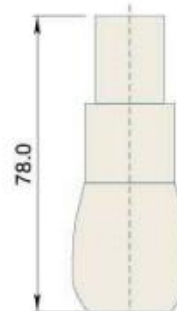
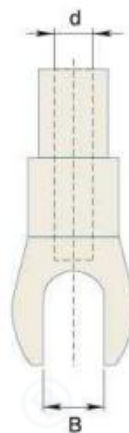

型号 Type	材质 Material	重量 Weight
HarP763	Nylon	45g

HarP764 Series Component

HarP764型导向叉B

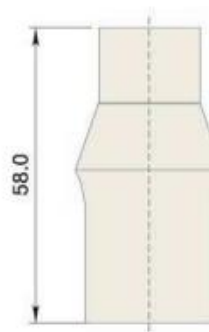
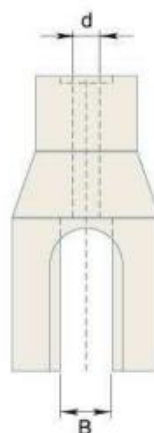

型号 Type	材质 Material	重量 Weight
HarP764	Nylon	40g

HarP765 Series Component

HarP765型导向叉C

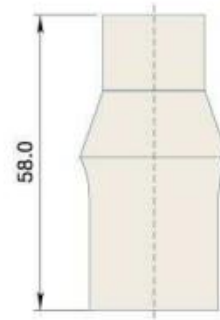
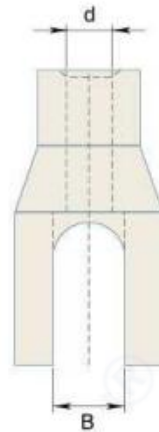

型号 Type	材质 Material	重量 Weight
HarP765	Nylon	40g

HarP766 Series Component

HarP766型导向叉D

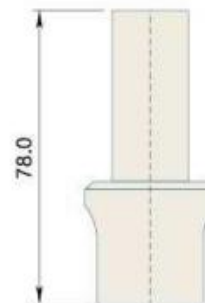
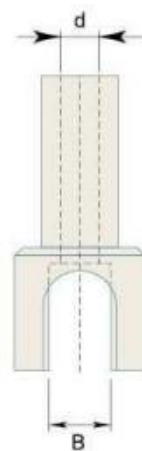

型号 Type	材质 Material	重量 Weight
HarP766	Nylon	45g

HarP767 Series Component

HarP767型导向叉E

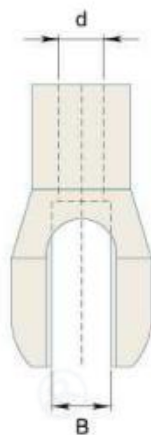

型号 Type	材质 Material	重量 Weight
HarP767	尼龙/Nylon	40g

HarP768 Series Component

HarP768型导向叉F

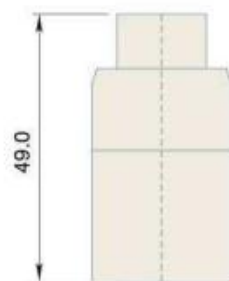
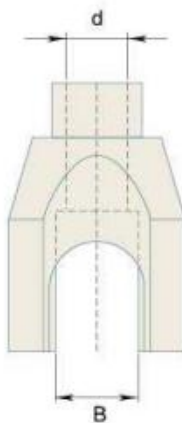

型号 Type	材质 Material	重量 Weight
HarP768	Nylon	40g

HarP769 Series Component

HarP769型导向叉G

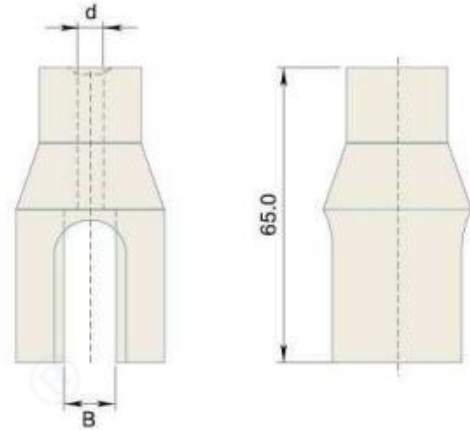

型号 Type	材质 Material	重量 Weight
HarP769	尼龙/Nylon	40g

HarP770 Series Water Sink Bracket

HarP770型水槽吊架

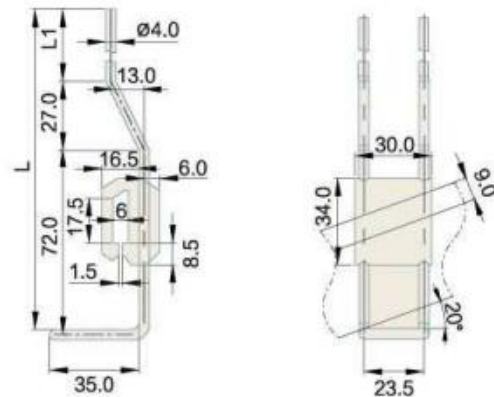
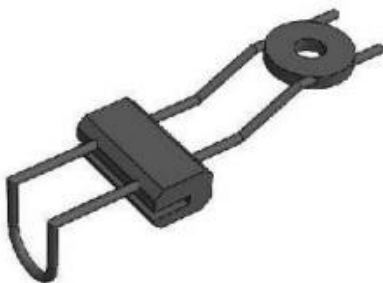

型号 Type	材质 Material	重量 Weight
HarP770	304不锈钢/SUS304	95g

HarP771 Series Water Sink Bracket

HarP771型水槽吊架

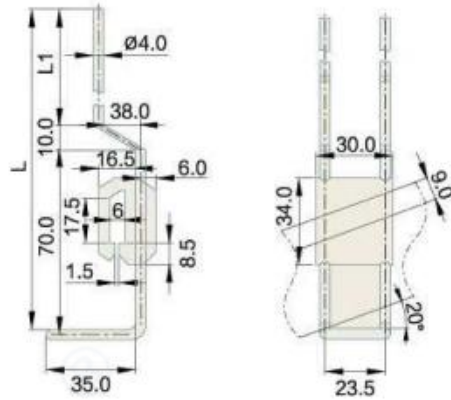
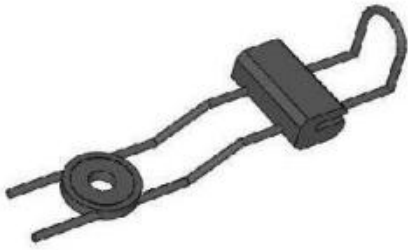

型号 Type	材质 Material	重量 Weight
HarP771	304不锈钢/SUS304	95g

HarP772 Series Water Sink Bracket

HarP772型水槽吊架

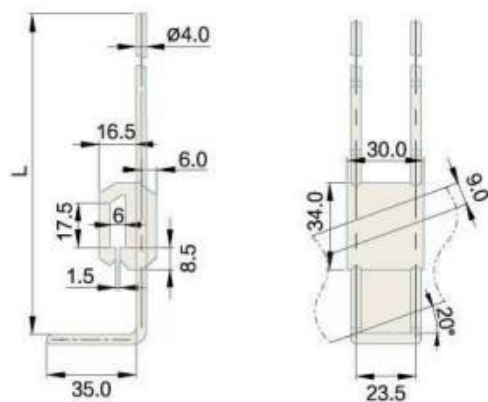
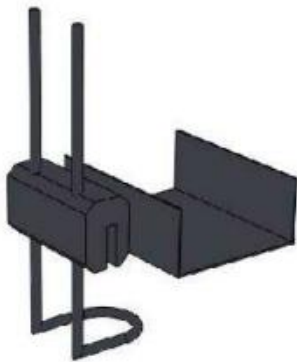

型号 Type	材质 Material	重量 Weight
HarP772	304不锈钢/SUS304	95g

HarP773 Series Water Sink Bracket

HarP773型水槽吊架

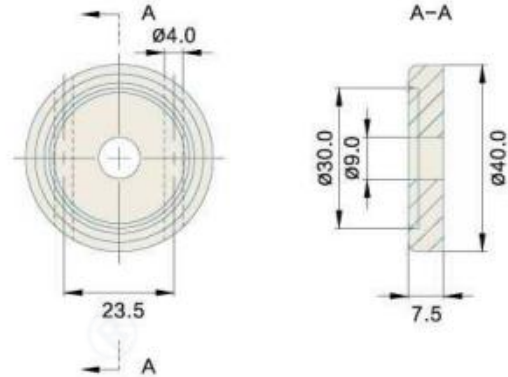

型号 Type	材质 Material	重量 Weight
HarP773	304不锈钢/SUS304	10g

HarP774 Series T Clamp

HarP774型接头 T型

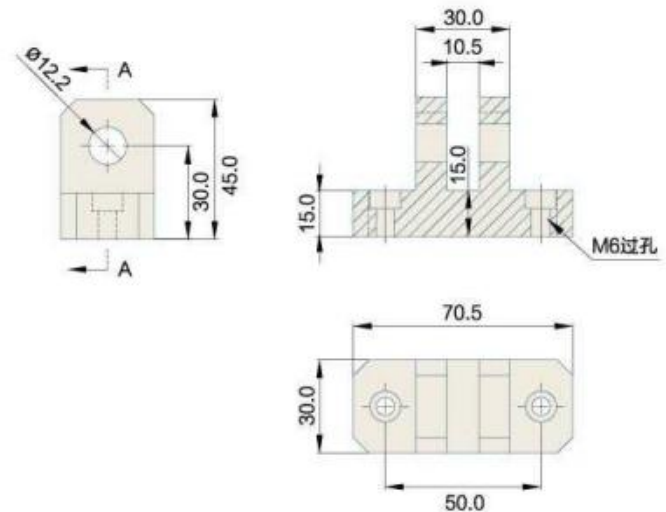
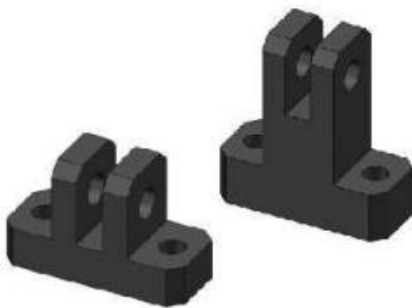

型号 Type	材质 Material	重量 Weight
HarP774	尼龙/Nylon	70g

HarP775 Series Clamp

HarP775型接头

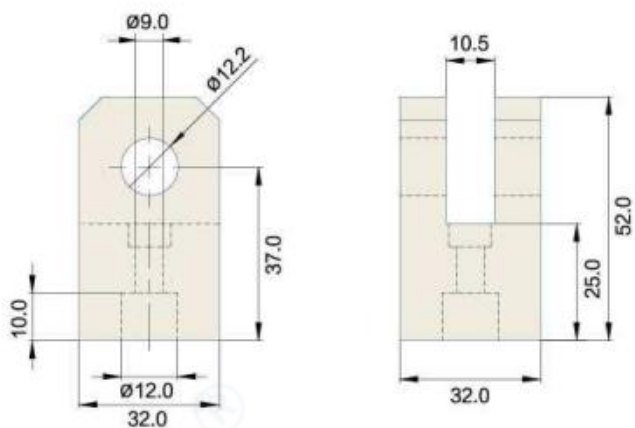

型号 Type	材质 Material	重量 Weight
HarP775	尼龙/Nylon	40g

HarP776 Series T Clamp

HarP776型接头 T型

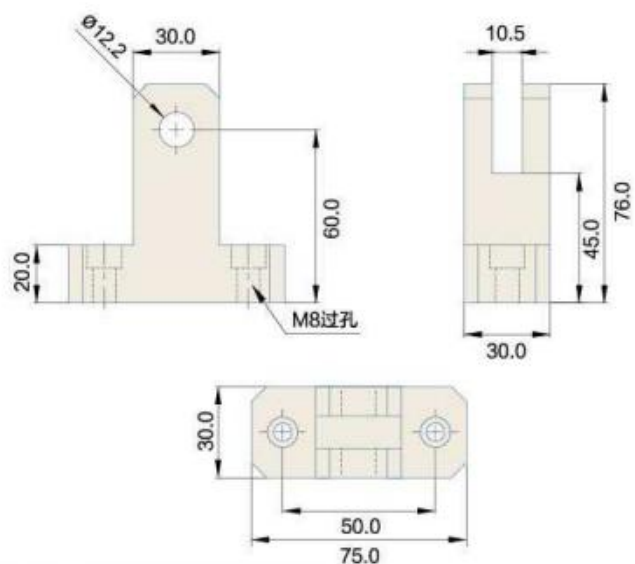

型号 Type	材质 Material	重量 Weight
HarP776	尼龙/Nylon	70g

HarP777 Series L Type SUS Bracket

HarP777型不锈钢支架 L型

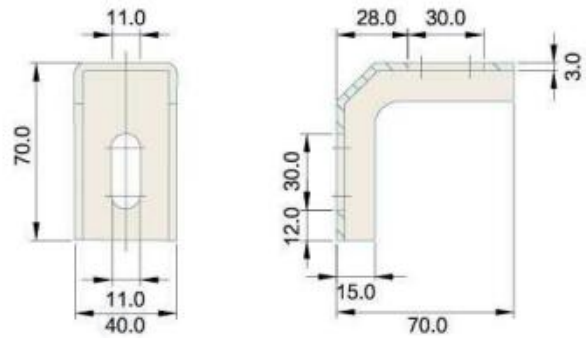

型号 Type	材质 Material	重量 Weight
HarP777	304不锈钢/SUS304	150g

HarP778 Series L Type SUS Bracket

HarP778型不锈钢支架 L型

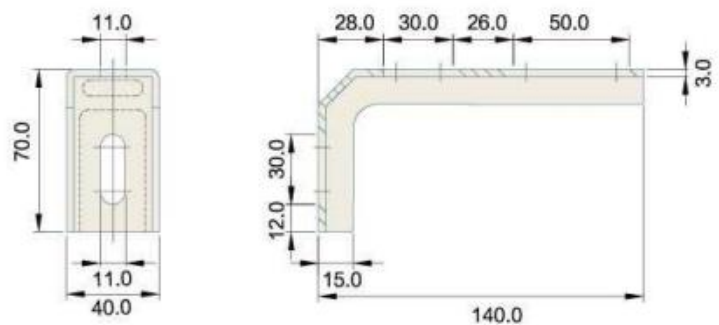

型号 Type	材质 Material	重量 Weight
HarP778	304不锈钢/SUS304	200g

HarP779 Series L Type SUS Bracket

HarP779型不锈钢支架L型

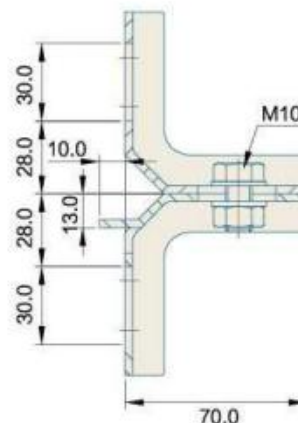
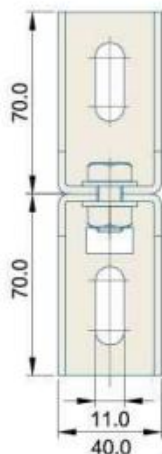

型号 Type	材质 Material	重量 Weight
HarP779	304不锈钢/SUS304	300g

HarP780 Series L Type SUS Bracket

HarP780型不锈钢支架L型

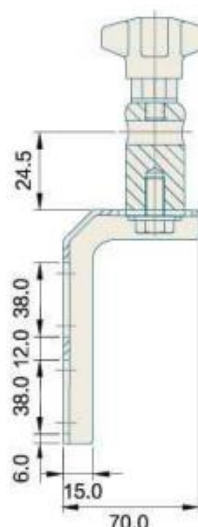
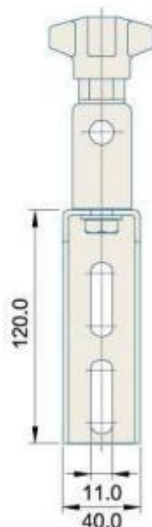

型号 Type	材质 Material	重量 Weight
HarP780	304不锈钢/SUS304	450g

HarP781 Series Cross Clamp

HarP781型调整头组(短)

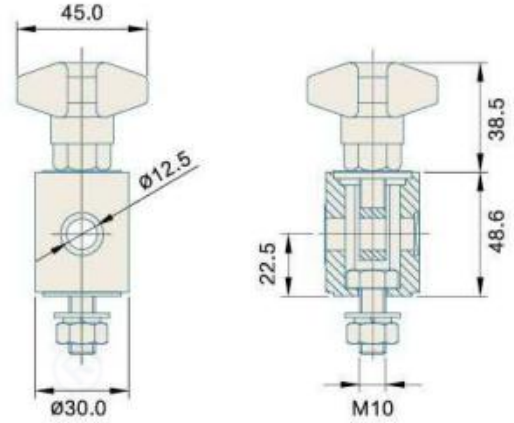

型号 Type	材质 Material	重量 Weight
HarP781	Nylon	85g

HarP782 Series Cross Clamp

HarP782型调整头组(长)

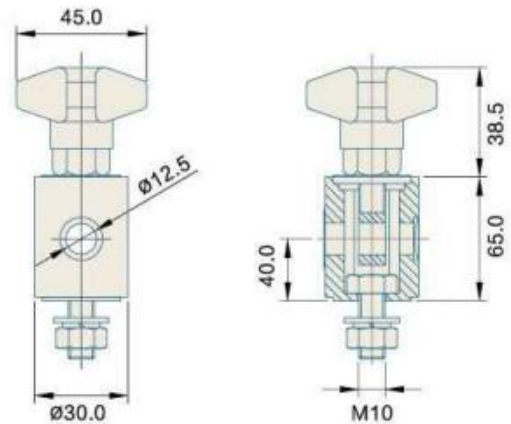

型号 Type	材质 Material	重量 Weight
HarP782	Nylon	100g

HarP783 Series Bracket

HarP783型金属固定头组

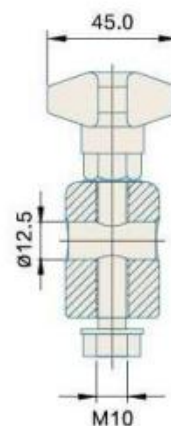
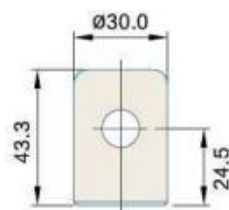

型号 Type	材质 Material	重量 Weight
HarP783	SS304	250g

HarP784 Series Clamp For Sensors

HarP784型金属固定头组(长)

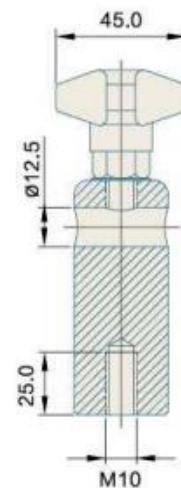
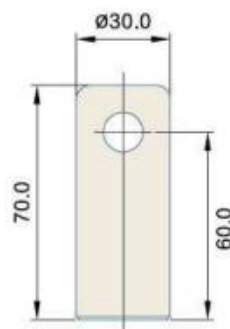

型号 Type	材质 Material	重量 Weight
HarP784	SS304	450g

HarP785 Series Cross Clamp

HarP785型调整头组支架

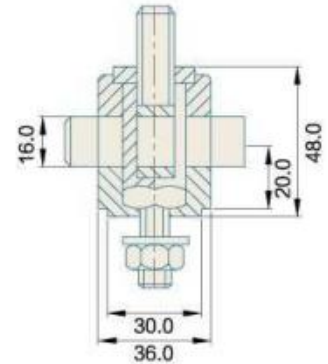
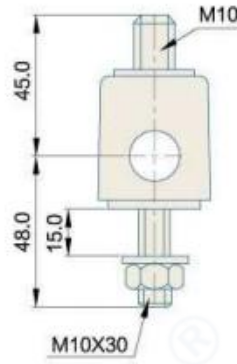

型号 Type	材质 Material	重量 Weight
HarP785	Nylon	120g

HarP786 Series Clamp For Bracket A

HarP786型星型螺钉

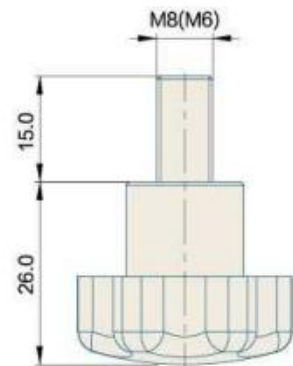
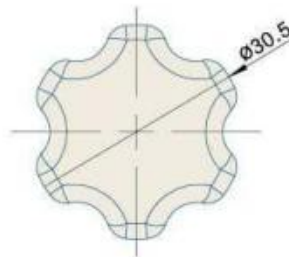

型号 Type	材质 Material	重量 Weight
HarP786	Nylon	100g

HarP787 Series Hand Knob

HarP787型内牙万向扳手

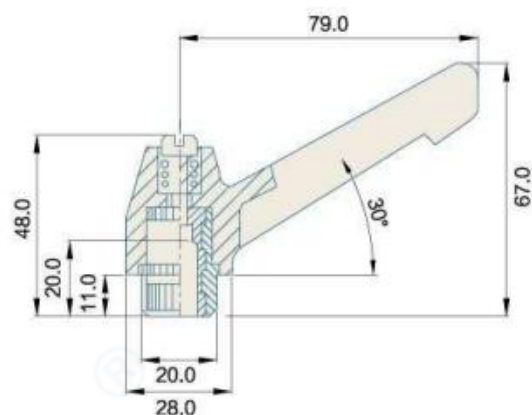
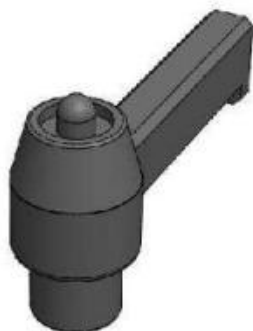

型号 Type	材质 Material	重量 Weight
HarP787	尼龙/Nylon	85g

HarP788 Series Hand Knob

HarP788型外牙万向扳手

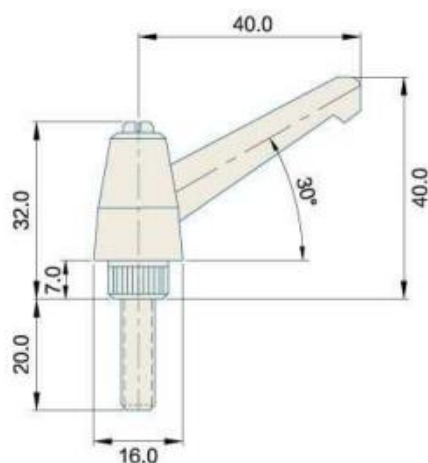
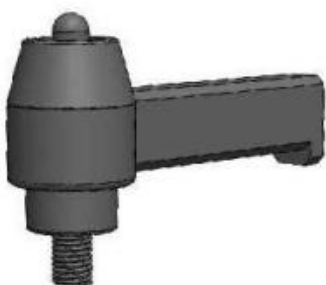

型号 Type	材质 Material	重量 Weight
HarP788	Nylon+SS304	50g

HarP789 Series Single Connect Part

HarP789型单接接头

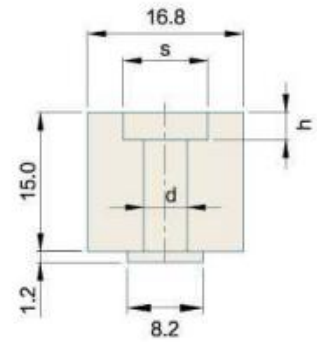
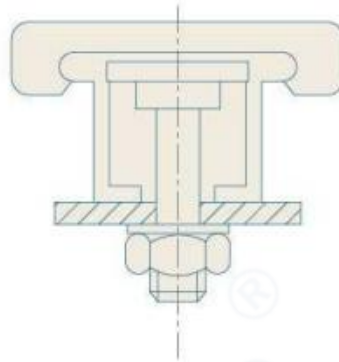

型号 Type	材质 Material	重量 Weight
HarP789	Nylon+SS304	25g

HarP790 Series Double Connect Part

HarP790型双接头

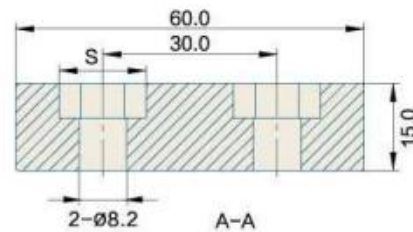
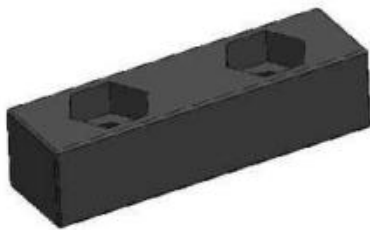

型号 Type	材质 Material	重量 Weight
HarP790	Nylon+SS304	50g

HarP791 Series Fixed Ring

HarP791型圆孔固定环

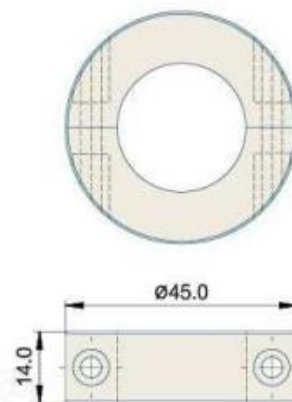

型号 Type	材质 Material	重量 Weight
HarP791	Nylon+SS304	20/25/30/40g

备注：圆孔 Round Bore: 20/25/30/40mm

HarP792 Series Fixed Ring

HarP792型方孔固定环

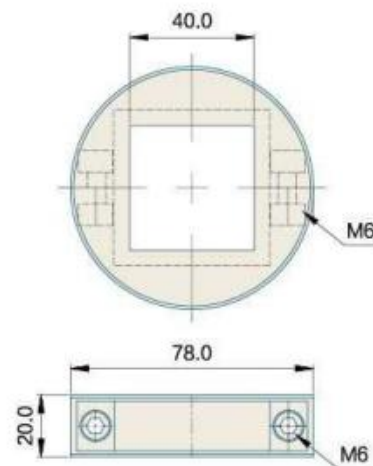
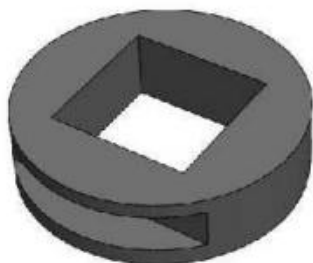

型号 Type	材质 Material	重量 Weight
HarP792	Nylon+SS304	50g

备注：方孔 Square Bore: 40/45mm

HarP793 Series Fixed Ring

HarP793型方孔固定环

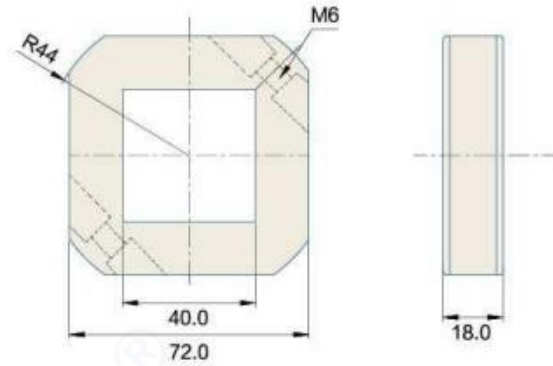

型号 Type	材质 Material	重量 Weight
HarP793	Nylon+SS304	80g

HarP794 Series T Clamp

HarP794型双夹方形夹

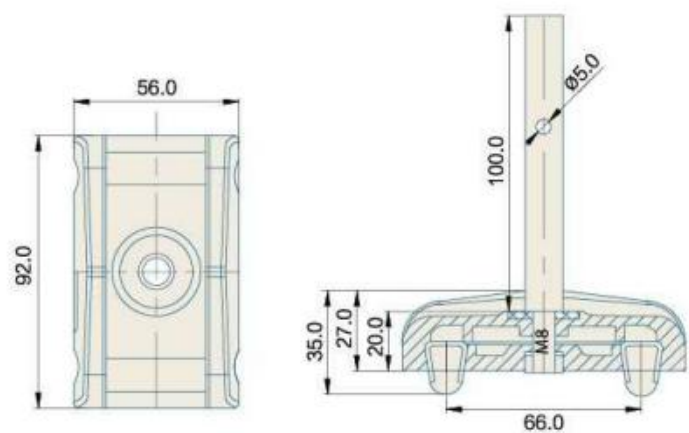

型号 Type	材质 Material	重量 Weight
HarP794	Nylon+SS304	180g

HarP797 Series Pulley

HarP797型拖轮

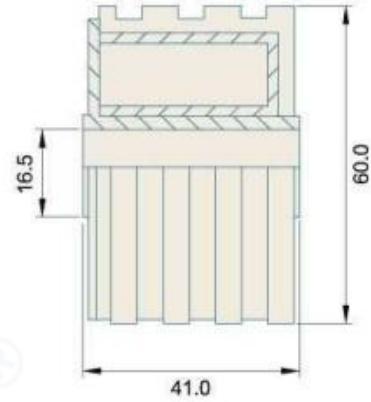

型号 Type	材质 Material	重量 Weight
HarP797	PE	45g

HarP798 Series Pulley

HarP798型包胶拖轮

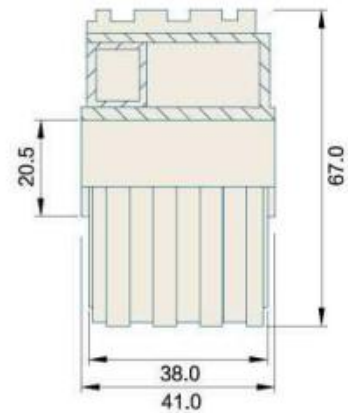

型号 Type	材质 Material	重量 Weight
HarP798	PE	60g

HarP799 Series Pulley

HarP799型包胶拖轮

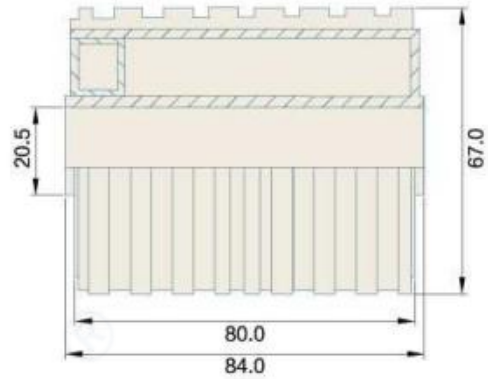

型号 Type	材质 Material	重量 Weight
HarP799	PE	116g

HarP7100 Series Pulley

HarP7100型包胶拖轮

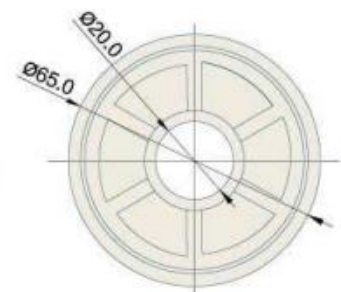
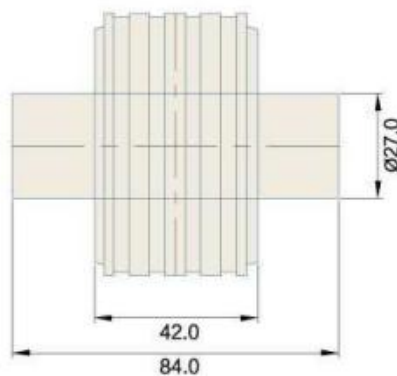
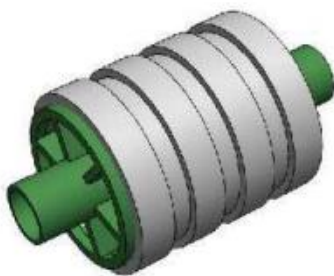

型号 Type	材质 Material	重量 Weight
HarP7100	PE	70g

HarP7101 Series Inner Set

HarP7101型圆管塞头

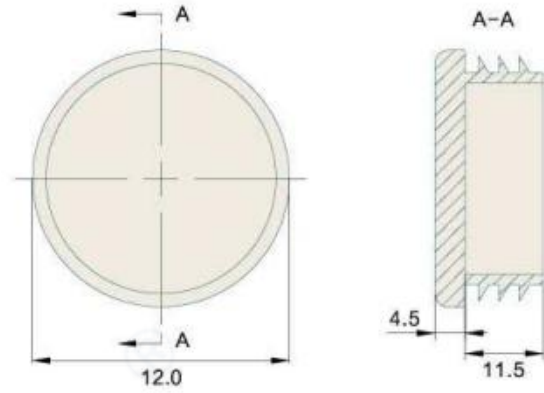

型号 Type	材质 Material	重量 Weight
HarP7101	BLACK PE	2g

HarP7102 Series Inner Set

HarP7102型方管塞头

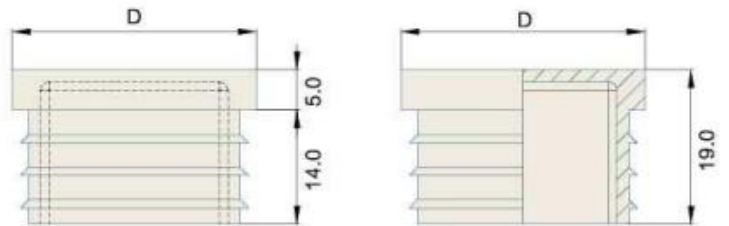

型号 Type	材质 Material	尺寸 SIZE	重量 Weight
HarP7102	BLACK PE	40x40mm / 50x50mm	7.6g / 11.7g

HarP7103 Series Cover

HarP7103型PVC圆套

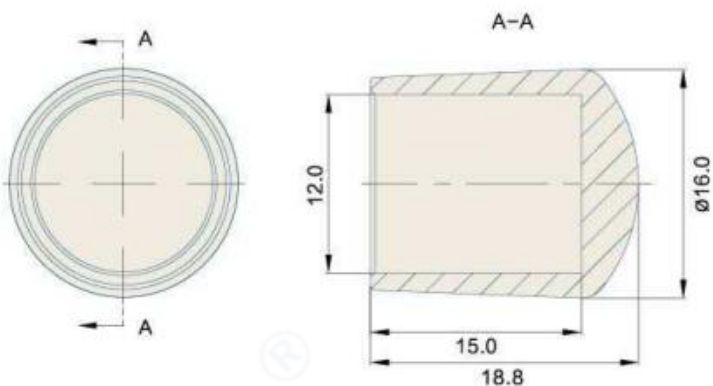

型号 Type	材质 Material	重量 Weight
HarP7103	BLACK PE	1g

HarP7104 Series Guide Vane

HarP7104型导滑片

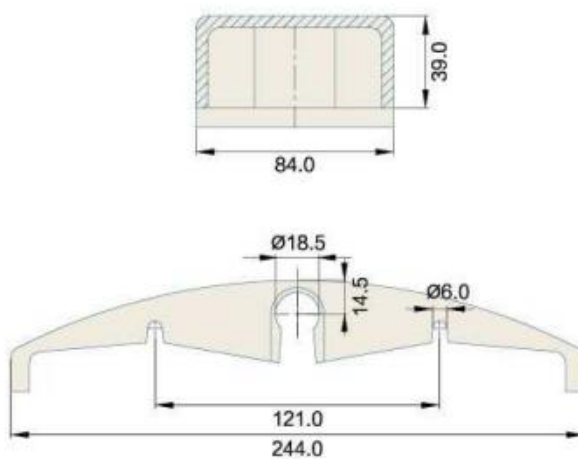

型号 Type	材质 Material	重量 Weight
HarP7104	PE	76g

HarP7105 Series Bearing

HarP7105型不锈钢轴承座

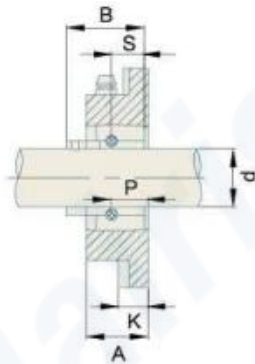
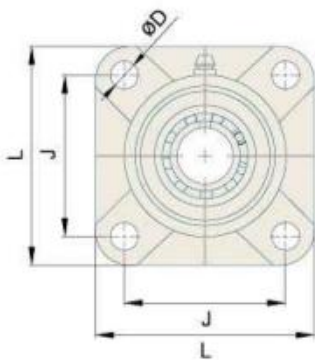

材质 Material: 奥氏体不锈钢, 304不锈钢, 碳钢 201SUS / 304SUS/Carbon Steel

名称 Name	型号 Type	d (mm)	L (mm)	J (mm)	K (mm)	A (mm)	D (mm)	B (mm)	S (mm)	P (mm)	重量 Weight
F204	HarP7105	20.0	86.0	64.0	11.0	25.5	12.0	31.0	12.7	15.0	500g
F205		25.0	95.0	70.0	13.0	27.0	12.0	34.0	14.3	16.0	650g
F206		30.0	108.0	83.0	13.0	31.0	12.0	38.1	15.9	18.0	1000g
F207		35.0	117.0	92.0	15.0	34.0	12.0	42.9	17.5	19.0	1250g
F208		40.0	130.0	102.0	15.0	36.0	12.0	49.2	19.0	21.0	1350g

HarP7106 Series Bearing

HarP7106型轴承座

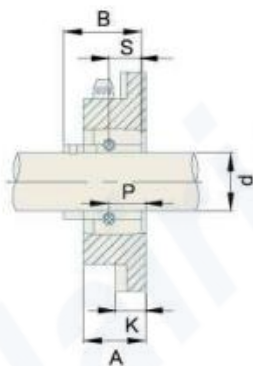
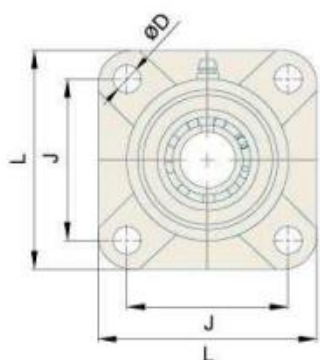
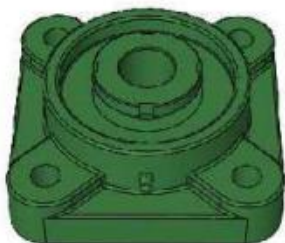

材质 Material: PBT Color: White/Black 轴承材质 Bearing Material: 奥氏体不锈钢, 304不锈钢, 碳钢 201SUS/304SUS/Carbon Steel

名称 Name	型号 Type	d (mm)	L (mm)	J (mm)	K (mm)	A (mm)	D (mm)	B (mm)	S (mm)	P (mm)	重量 Weight
F204	HarP7106	20.0	86.0	64.0	13.4	27.8	11.0	31.0	12.7	16.3	300g
F205		25.0	95.0	70.0	14.3	28.5	11.0	34.0	14.3	17.0	350g
F206		30.0	108.0	83.0	14.3	31.5	11.0	38.1	15.9	19.0	500g
F207		35.0	117.0	92.0	15.5	34.5	13.0	42.9	17.5	21.5	700g
F208		40.0	130.0	102.0	17.0	36.5	14.0	49.2	19.0	23.0	850g

HarP7107 Series Bearing

HarP7107型不锈钢轴承座

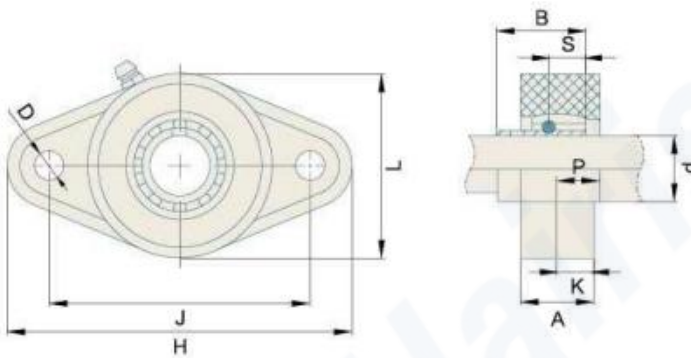
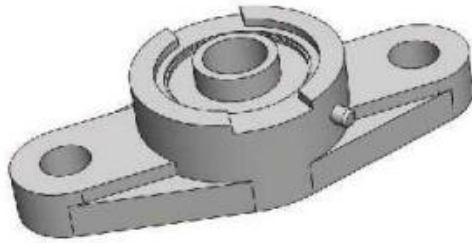

材质 Material: 奥氏体不锈钢, 304不锈钢, 碳钢 201SUS / 304SUS/Carbon Steel

名称 Name	型号 Type	d (mm)	H (mm)	L (mm)	J (mm)	K (mm)	A (mm)	D (mm)	B (mm)	S (mm)	P (mm)	重量 Weight
UCF204	HarP7107	20.0	113.0	60.0	90.0	11.0	25.5	12.0	33.3	12.7	15.0	350g
UCF205		25.0	130.0	68.0	99.0	13.0	27.0	16.0	35.7	14.3	16.0	550g
UCF206		30.0	148.0	80.0	117.0	13.0	31.0	16.0	40.2	15.9	18.0	750g
UCF207		35.0	161.0	90.0	130.0	15.0	34.0	16.0	44.1	17.5	19.0	1000g
UCF208		40.0	175.0	100.0	144.0	15.0	36.0	16.0	51.2	19.0	21.0	1350g

HarP7108 Series Bearing

HarP7108型轴承座

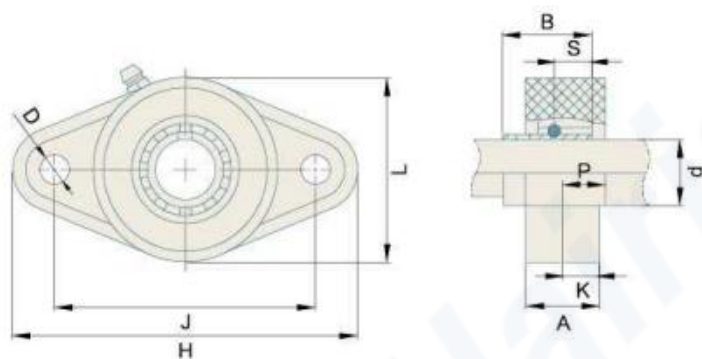
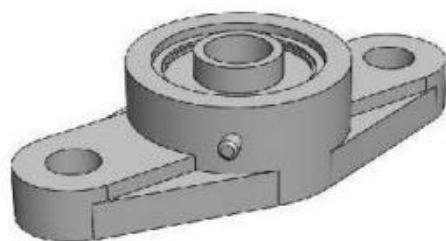

材质 Material: PBT Color: White/Black 轴承材质 Bearing Material: 奥氏体不锈钢, 304不锈钢, 碳钢 201SUS/304SUS/Carbon Steel

名称 Name	型号 Type	d (mm)	H (mm)	L (mm)	J (mm)	K (mm)	A (mm)	D (mm)	B (mm)	S (mm)	P (mm)	重量 Weight
UCF204	HarP7108	20.0	113.0	65.0	90.0	13.4	26.5	11.0	31.0	12.7	15.0	50g
UCF205		25.0	131.0	75.0	99.0	14.3	28.0	11.0	34.0	14.3	16.5	80g
UCF206		30.0	147.0	80.0	117.0	14.3	30.5	11.0	38.1	15.9	18.0	100g
UCF207		35.0	164.0	90.0	130.0	15.5	32.0	13.0	42.9	17.5	19.0	130g
UCF208		40.0	178.0	100.0	144.0	17.0	35.0	14.0	49.2	19.0	21.5	160g

HarUS-8T Series

HarUS-8T型

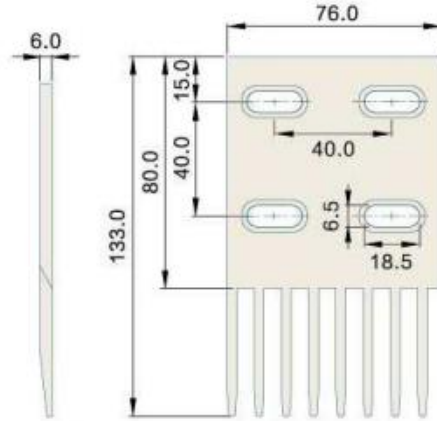

Har100-16T Series

Har100-16T型

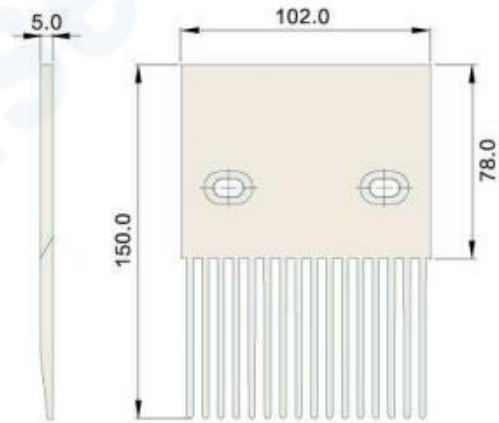

Har400-18T Series

Har400-18T型

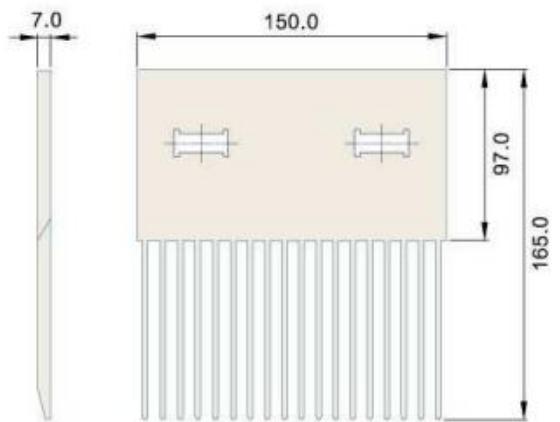
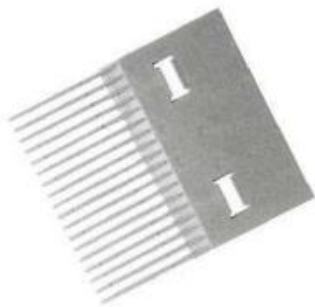

Har900-18T Series

Har900-18T型

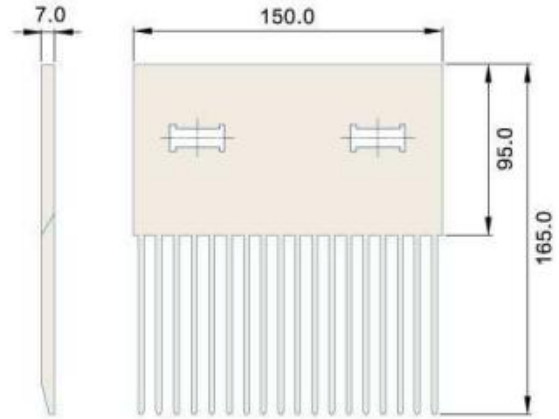

Har900-5T Series

Har900-5T型

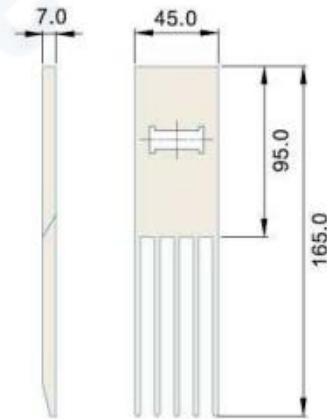

Har900-6T Series

Har900-6T型

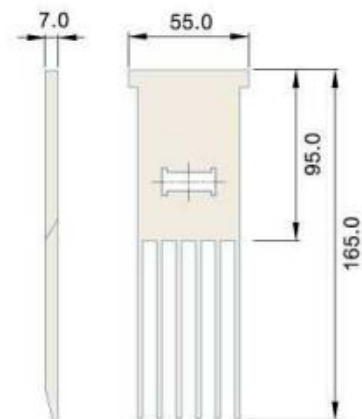

Har2100 Series

Har2100型动态梳子板

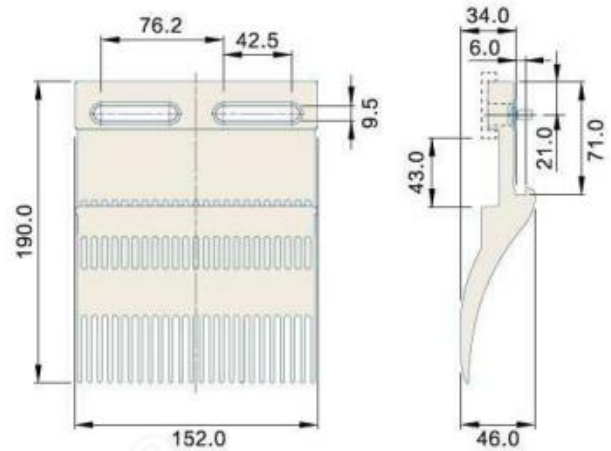

Har3110-24T Series

Har3110-24T型

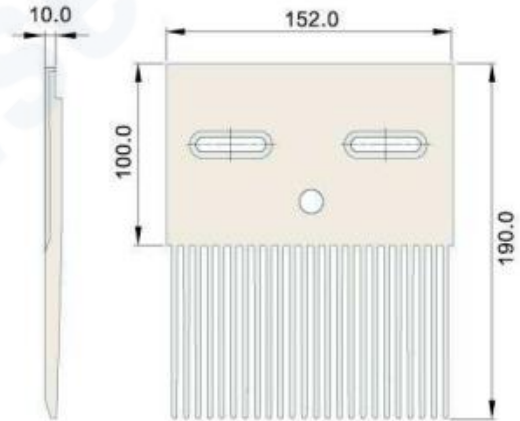

Har4707-12T Series

Har4707-12T型

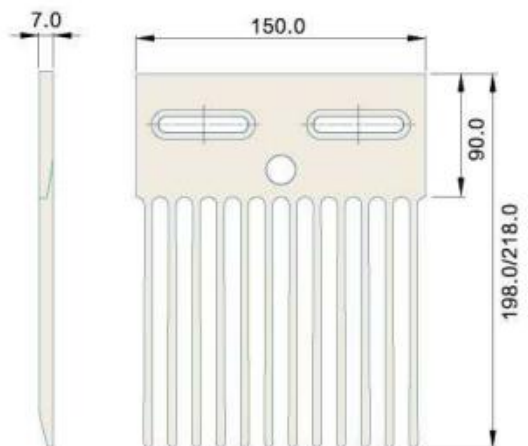

Har4809-28T Series

Har4809-28T型

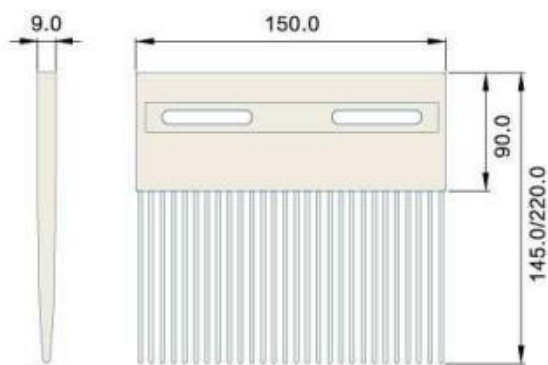

Har5997-12T Series

Har5997-12T型

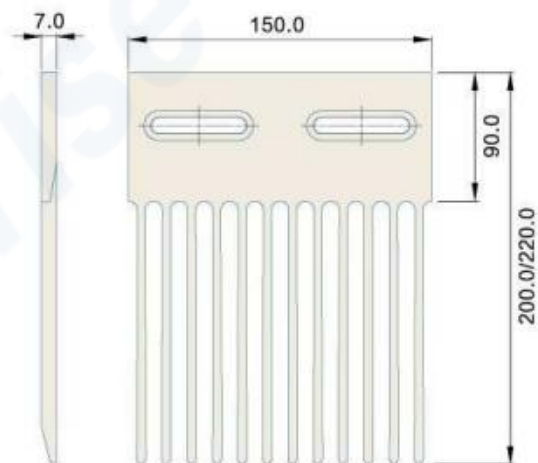

HarAJM-24T Series

HarAJM-24T型

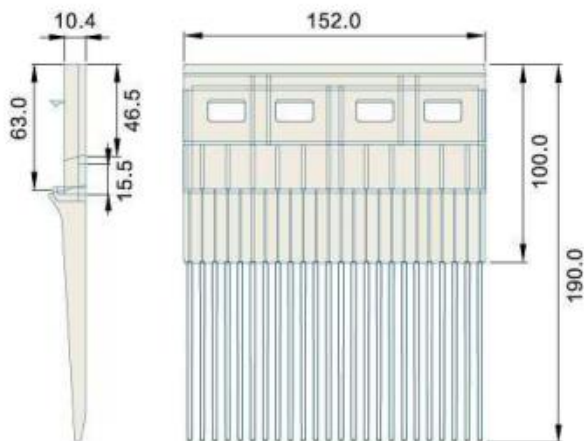

Har6300-24T Series

Har6300-24T型

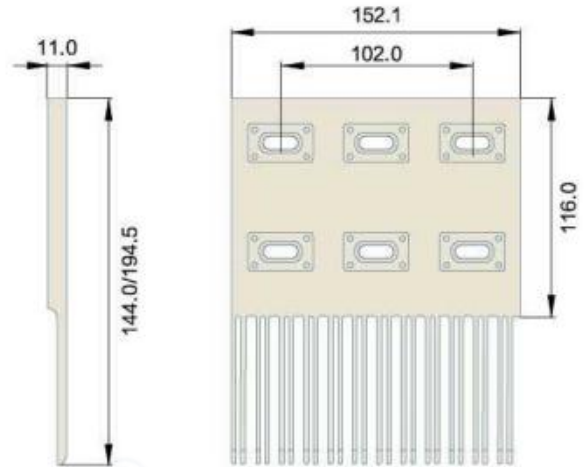

Har7400-24T Series

Har7400-24T型

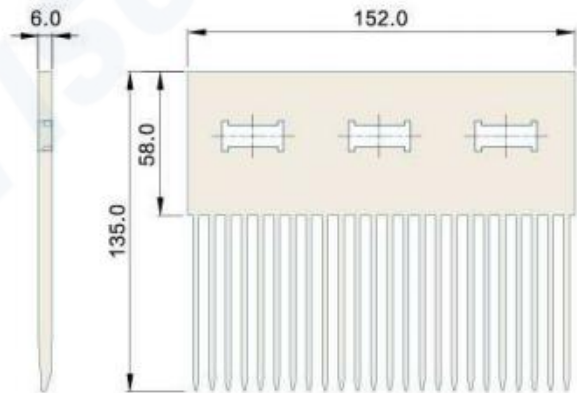

Har7880-18T Series

Har7880-18T型

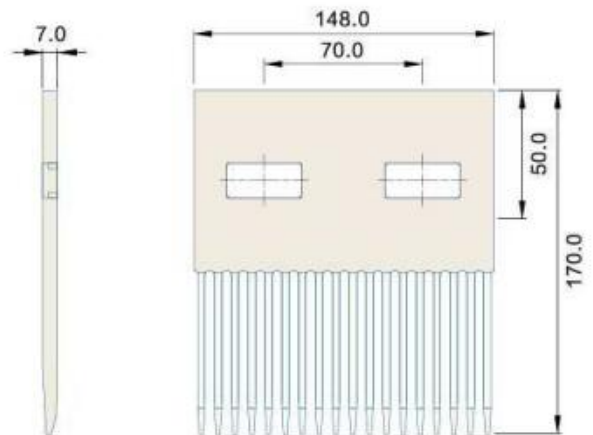

HarURB-15T Series

HarURB-15T型

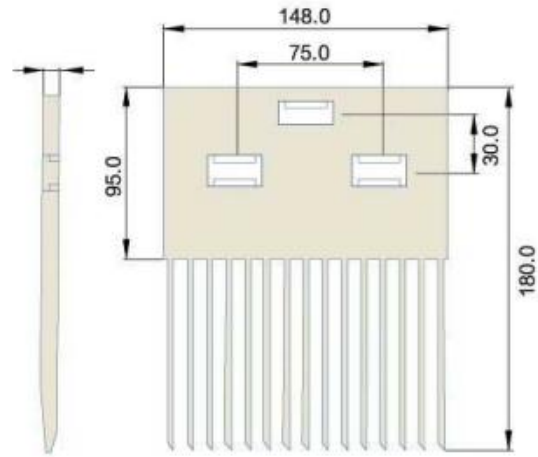

HarRHN-18T Series

HarRHN-18T型

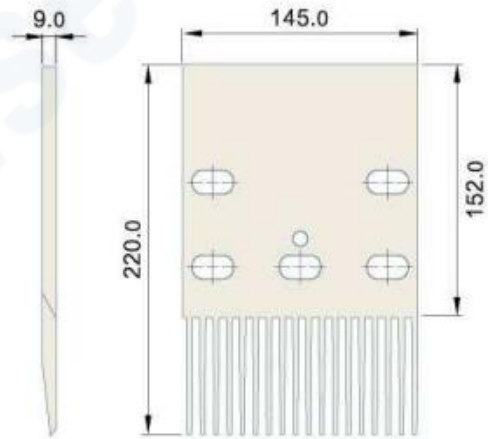

HarNDN-8T Series

HarNDN-8T型

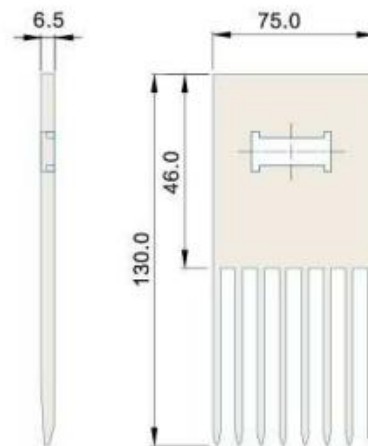
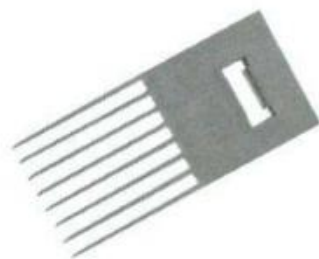

HarNHM-18T Series

HarNHM-18T型

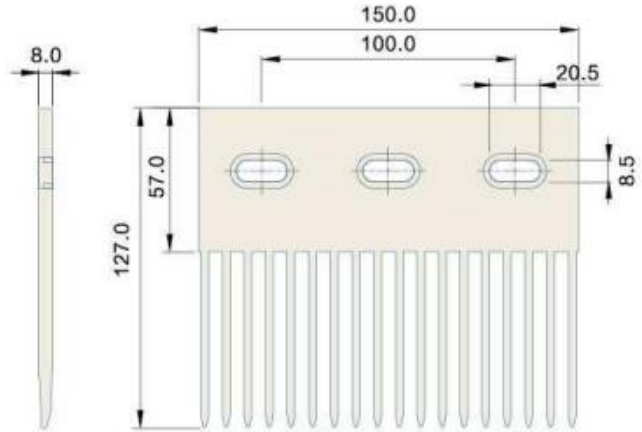

Har845-10T Series

Har845-10T型

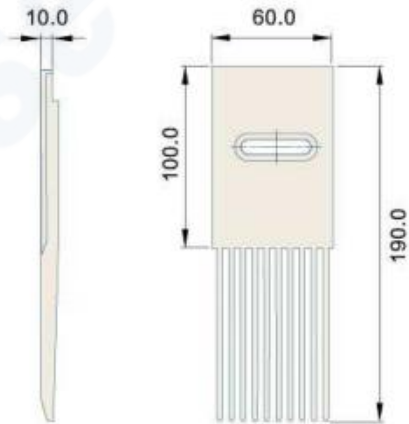

Har1000-32T Series

Har1000-32T型

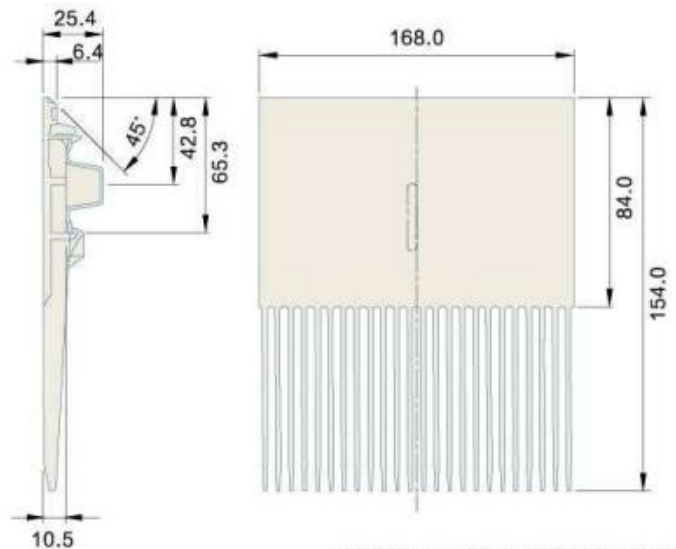

HarZMB-2 Series

HarZMB-2型

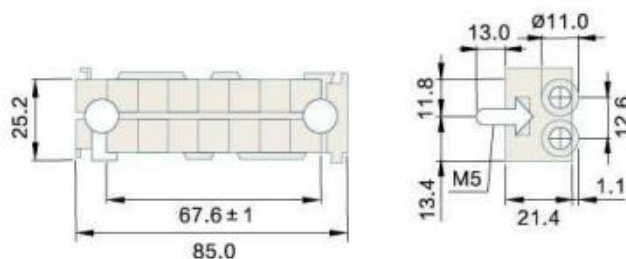

HarZMB-3 Series

HarZMB-3型

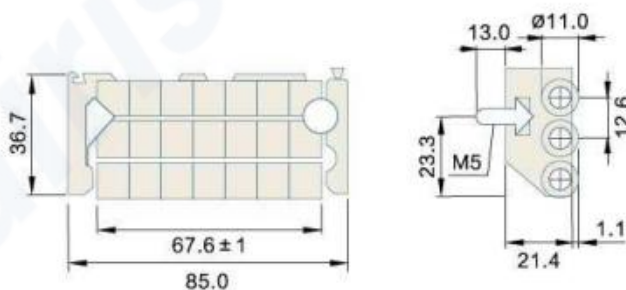

HarZMB-6 Series

HarZMB-6型

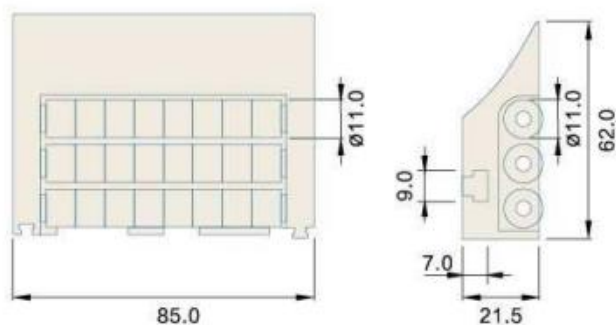

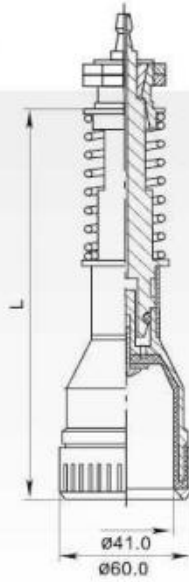
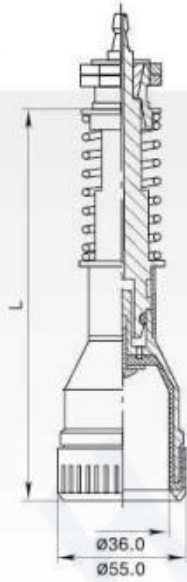

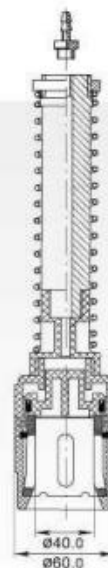
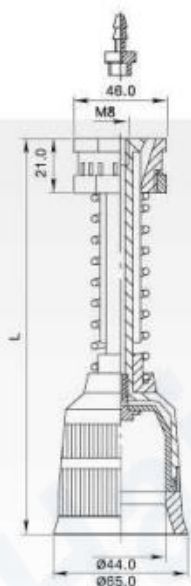



880尖角型弯座单轨



880TAB有翼型弯座单轨



882有翼型弯座单轨



880尖角型弯座双轨



880TAB有翼型弯座双轨



882有翼型弯座双轨



1873系列弯座单轨



1873系列弯座双轨



Har1050弯座系列

材质 Material: 超高分子聚乙烯+油尼龙

规格 Reference	K325	K450	K600	K750	K1000	K1200
单轨半径R	500.0	500.0	610.0	610.0	610.0	610.0
单轨宽度W	100.0	125.0	160.0	200.0	270.0	320.0
双轨半径R	586.0	617.0	765.0	804.0	867.0	918.0
双轨宽度W	186.0	242.0	315.0	394.0	527.0	628.0
三轨半径R	672.0	734.0	920.0	998.0	1124.0	1226.0
三轨宽度W	272.0	359.0	470.0	588.0	784.0	936.0
四轨半径R	758.0	851.0	1075.0	1192.0	1381.0	1534.0
四轨宽度W	358.0	476.0	625.0	782.0	1041.0	1244.0
节距T	86.0	117.0	155.0	194.0	257.0	308.0
角度	90.0	90.0	90.0	90.0	90.0	90.0
厚度H	35.0	35.0	35.0	35.0	35.0	35.0

812 Slat Top Chains Straight Guide

812-K325 金属链板直行轨道

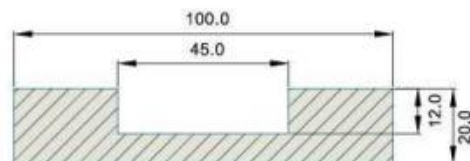
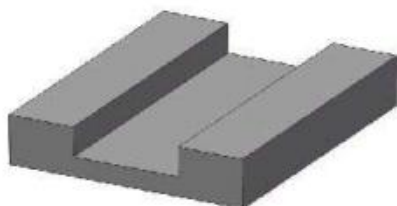

适用链板类型 Type Number	链板宽度 Top Chain Width (mm)	转弯半径 Radius (mm)	弯轨宽度 Conner Track Width (mm)
812-K325 Top Chain	82.6	—	100.0

备注：图纸仅供参考，可按客户图纸加工 Just For Reference, Can Be Customized As Well

880TAB Slat Top Chains Turning Guide

880TAB-K325 单道链板弯轨

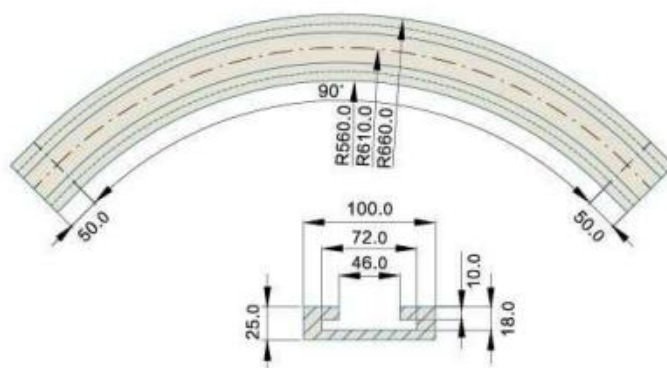

适用链板类型 Type Number	链板宽度 Top Chain Width (mm)	转弯半径 Radius (mm)	弯轨宽度 Conner Track Width (mm)
880TAB-K325 Top Chain	82.6	610.0	100.0

备注：图纸仅供参考，可按客户图纸加工 Just For Reference, Can Be Customized As Well

880TAB Slat Top Chains Turning Guide

880TAB-K450 链板弯轨

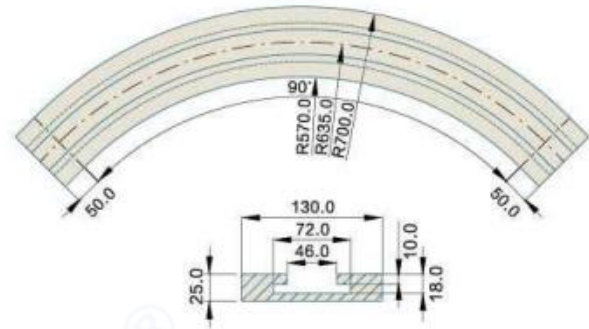

适用链板类型 Type Number	链板宽度 Top Chain Width (mm)	转弯半径 Radius (mm)	弯轨宽度 Conner Track Width (mm)
880TAB-K450 Top Chain	114.3	635.0	130.0

备注：图纸仅供参考，可按客户图纸加工 Just For Reference, Can Be Customized As Well

880TAB Slat Top Chains Turning Guide

880TAB-K450 三道链板弯轨

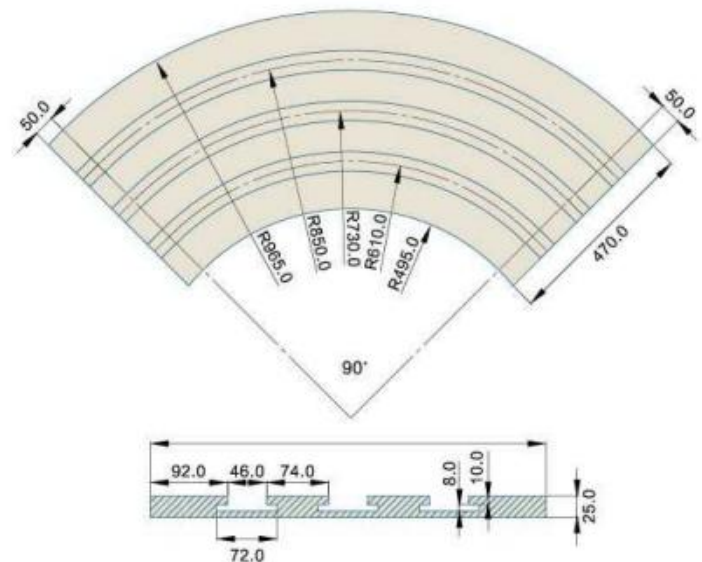

适用链板类型 Type Number	链板宽度 Top Chain Width (mm)	转弯半径 Radius (mm)	弯轨宽度 Conner Track Width (mm)
880TAB-K450 Top Chain	114.3	730.0	470.0

备注：图纸仅供参考，可按客户图纸加工 Just For Reference, Can Be Customized As Well

880M Slat Top Chains Turning Guide

880M-K325/K450 塑料链板弯轨

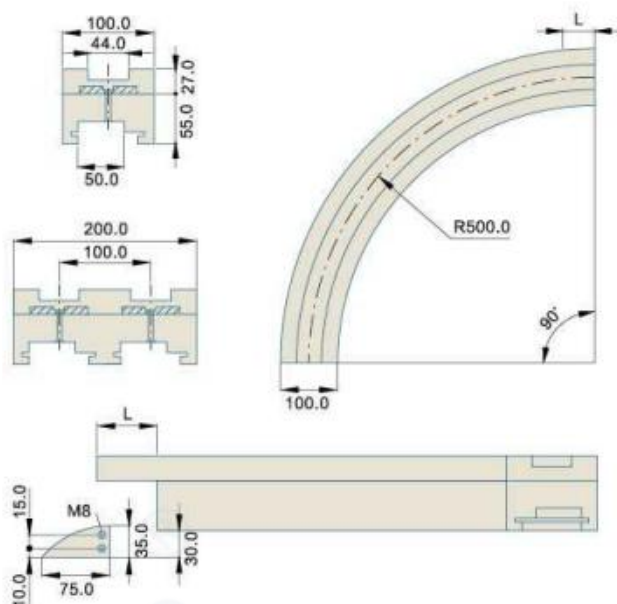

适用链板类型 Type Number	链板宽度 Top Chain Width (mm)	转弯半径 Radius (mm)	弯轨宽度 Conner Track Width (mm)
880M-K325 Top Chain	82.6	500.0	100.0
880M-K450 Top Chain	114.3	610.0	130.0

备注：图纸仅供参考，可按客户图纸加工 Just For Reference, Can Be Customized As Well

880 Slat Top Chains Turning Guide

880-K325 尖角链板弯轨

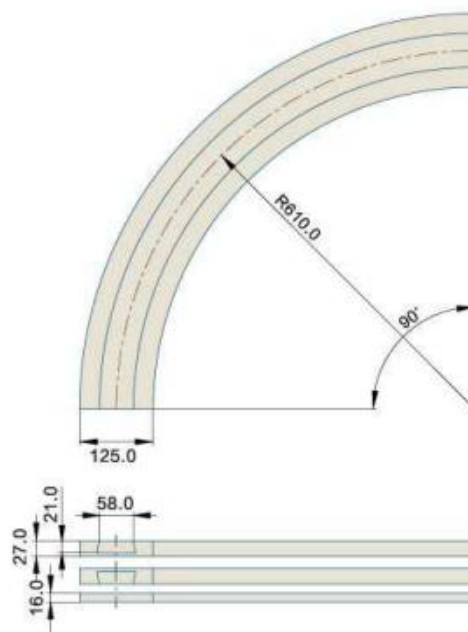

适用链板类型 Type Number	链板宽度 Top Chain Width (mm)	转弯半径 Radius (mm)	弯轨宽度 Conner Track Width (mm)
880-K325 Top Chain	82.6	500.0	100.0

备注：图纸仅供参考，可按客户图纸加工 Just For Reference, Can Be Customized As Well

880 Slat Top Chains Turning Guide

880-K450 尖角链板弯轨

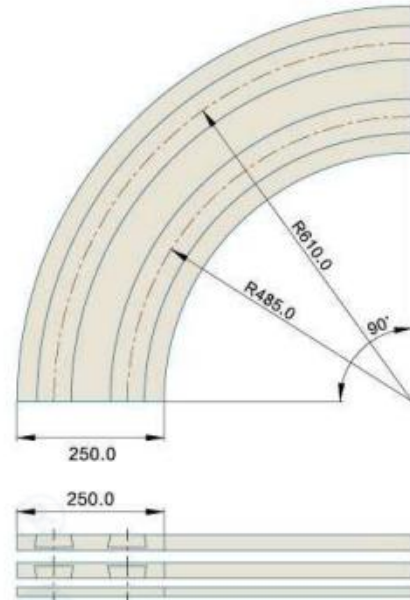

适用链板类型 Type Number	链板宽度 Top Chain Width (mm)	转弯半径 Radius (mm)	弯轨宽度 Conner Track Width (mm)
880-K450 Top Chain	114.3	610.0	125.0

备注：图纸仅供参考，可按客户图纸加工 Just For Reference, Can Be Customized As Well

882TAB Slat Top Chains Turning Guide

882TAB-K750 链板弯轨 90度

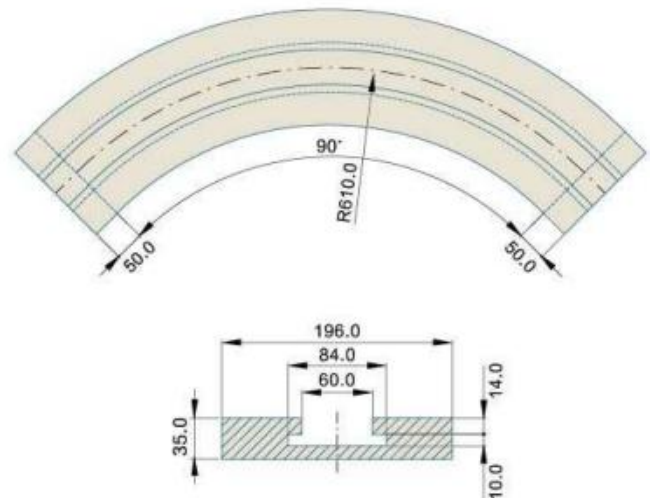

适用链板类型 Type Number	链板宽度 Top Chain Width (mm)	转弯半径 Radius (mm)	弯轨宽度 Conner Track Width (mm)
882TAB-K750 Top Chain	190.5	610.0	196.0

备注：图纸仅供参考，可按客户图纸加工 Just For Reference, Can Be Customized As Well

882TAB Slat Top Chains Turning Guide

882TAB-K1000 链板弯轨

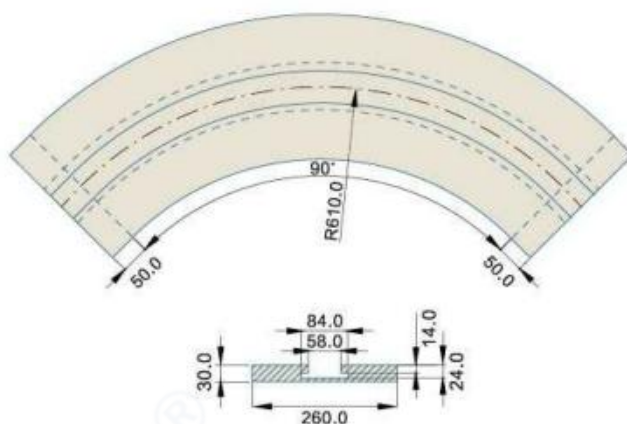

适用链板类型 Type Number	链板宽度 Top Chain Width (mm)	转弯半径 Radius (mm)	弯轨宽度 Conner Track Width (mm)
882TAB-K1000 Top Chain	254.0	610.0	260.0

备注：图纸仅供参考，可按客户图纸加工 Just For Reference, Can Be Customized As Well

882TAB Slat Top Chains Turning Guide

882TAB-K1200 链板弯轨

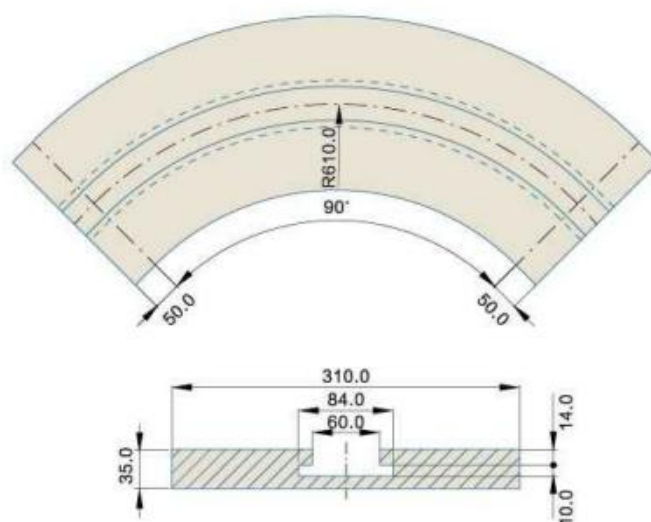

适用链板类型 Type Number	链板宽度 Top Chain Width (mm)	转弯半径 Radius (mm)	弯轨宽度 Conner Track Width (mm)
882TAB-K1200 Top Chain	304.8	610.0	310.0

备注：图纸仅供参考，可按客户图纸加工 Just For Reference, Can Be Customized As Well

882TAB Slat Top Chains Turning Guide

882TAB-K750 链板弯轨 180度

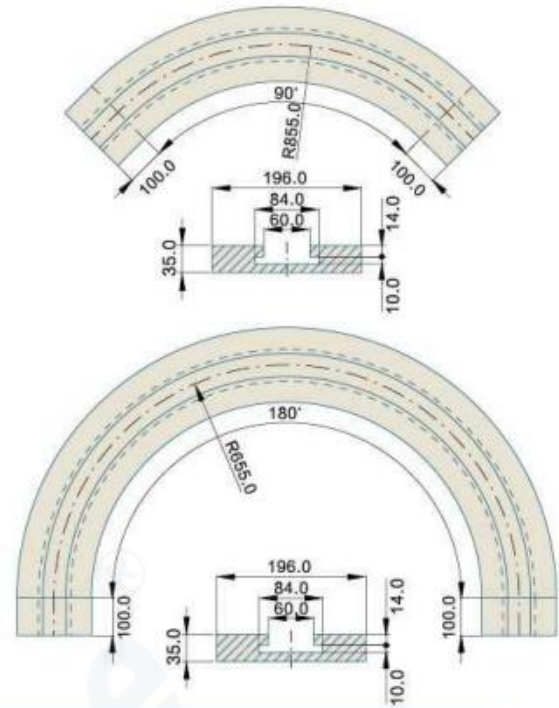

适用链板类型 Type Number	链板宽度 Top Chain Width (mm)	转弯半径 Radius (mm)	弯轨宽度 Conner Track Width (mm)
882TAB-K750 Top Chain	190.5	655.0/855.0	196.0

备注：图纸仅供参考，可按客户图纸加工 Just For Reference, Can Be Customized As Well

981M Slat Top Chains Turning Guide

981M 不锈钢链板弯轨

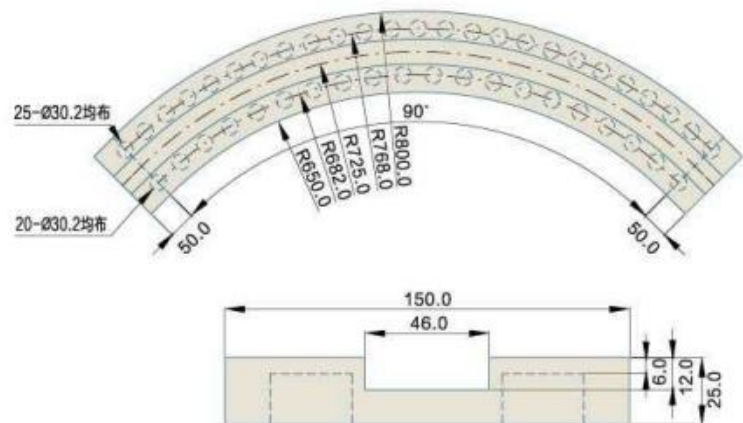

适用链板类型 Type Number	链板宽度 Top Chain Width (mm)	转弯半径 Radius (mm)	弯轨宽度 Conner Track Width (mm)
981M-K750 SUS Top Chain	190.5	800.0	150.0

备注：图纸仅供参考，可按客户图纸加工 Just For Reference, Can Be Customized As Well

830T Slat Top Chains Turning Guide

830T-K325 链板弯轨

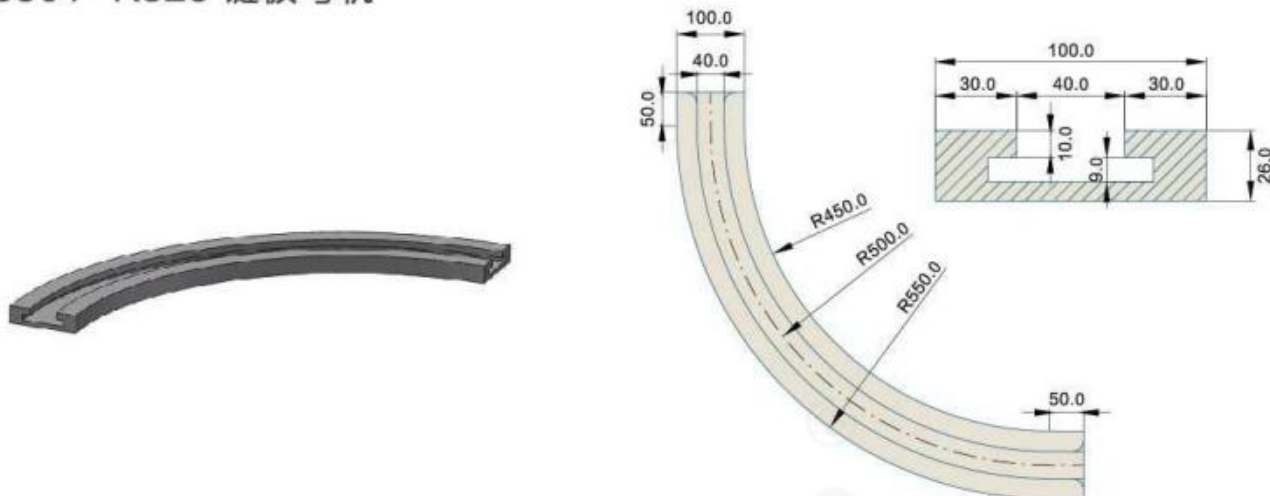

适用链板类型 Type Number	链板宽度 Top Chain Width (mm)	转弯半径 Radius (mm)	弯轨宽度 Conner Track Width (mm)
830T-K325 Flexible Chain	82.6	500.0	100.0

备注：图纸仅供参考，可按客户图纸加工 Just For Reference, Can Be Customized As Well

1050 Slat Top Chains Turning Guide

1050 链板弯轨

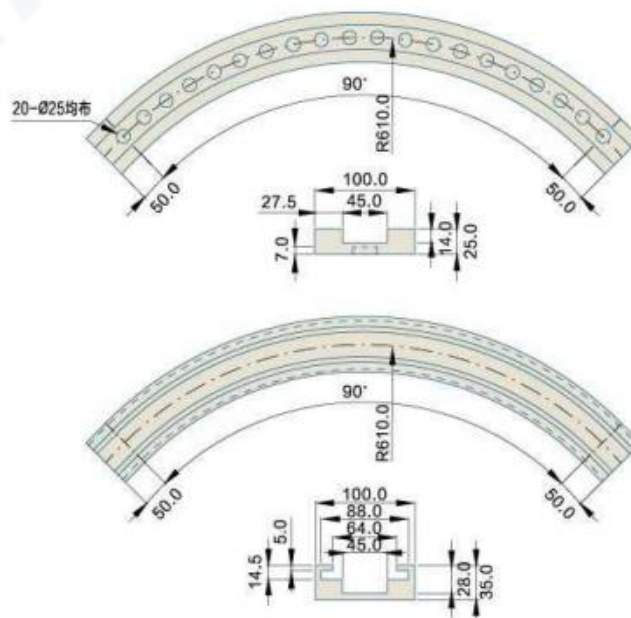

适用链板类型 Type Number	链板宽度 Top Chain Width (mm)	转弯半径 Radius (mm)	弯轨宽度 Conner Track Width (mm)
1050 Top Chain	83.8	610.0	100.0
1060 Top Chain	83.8	610.0	100.0

备注：图纸仅供参考，可按客户图纸加工 Just For Reference, Can Be Customized As Well

1700TAB Slat Top Chains Turning Guide

1700TAB 柔性链弯轨

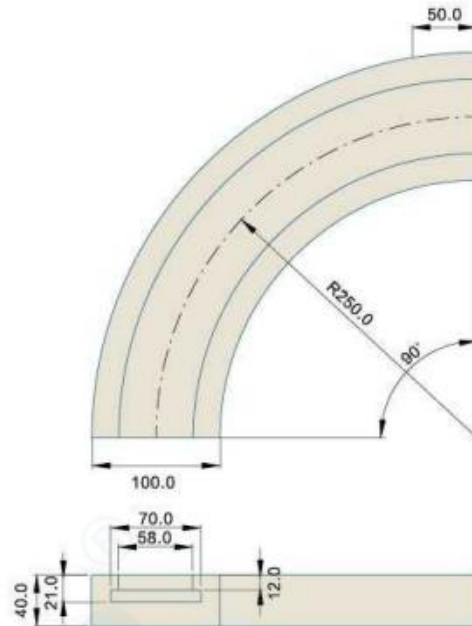

适用链板类型 Type Number	链板宽度 Top Chain Width (mm)	转弯半径 Radius (mm)	弯轨宽度 Conner Track Width (mm)
1700TAB	53.0	250.0	100.0

备注：图纸仅供参考，可按客户图纸加工 Just For Reference, Can Be Customized As Well

1873 Slat Top Chains Turning Guide

1873-K325 链板弯轨

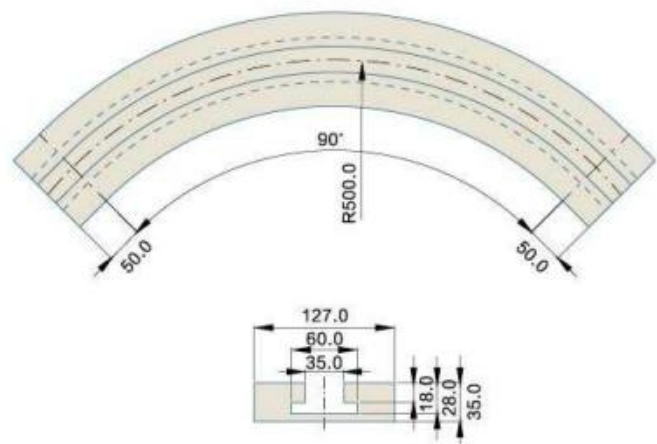

适用链板类型 Type Number	链板宽度 Top Chain Width (mm)	转弯半径 Radius (mm)	弯轨宽度 Conner Track Width (mm)
1873-K325 Top Chain	82.6	500.0	127.0

备注：图纸仅供参考，可按客户图纸加工 Just For Reference, Can Be Customized As Well

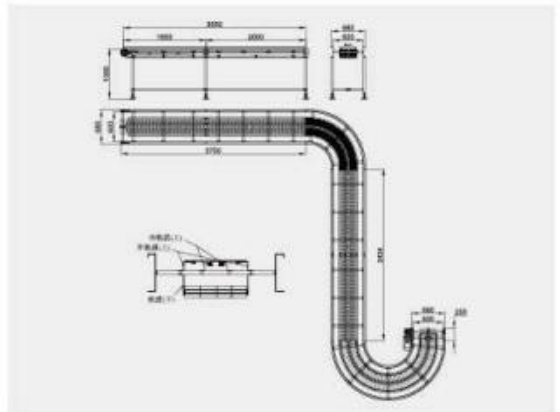
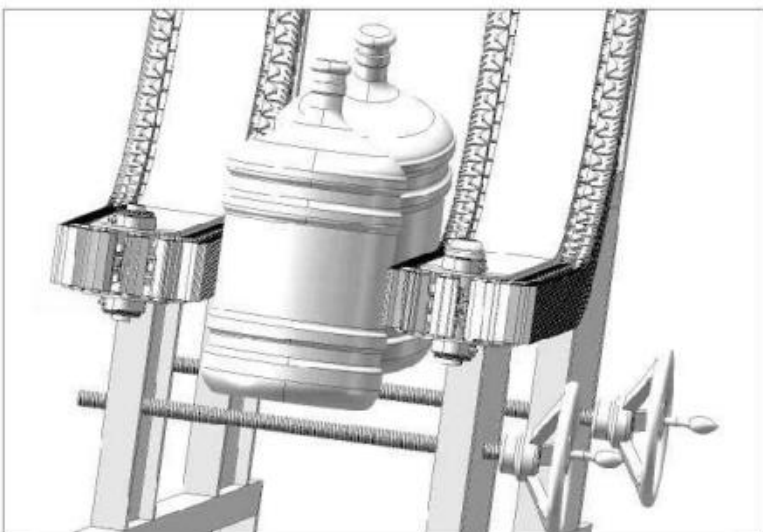
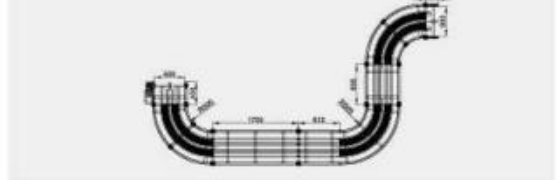
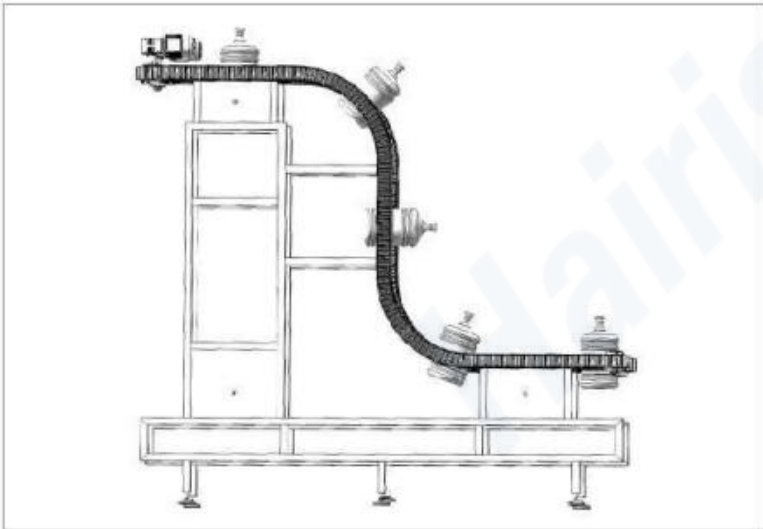
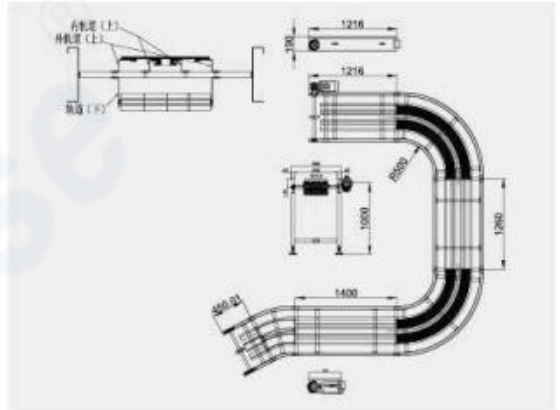
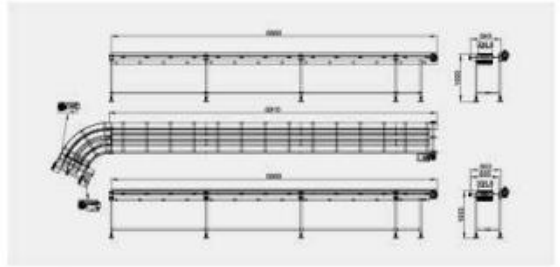
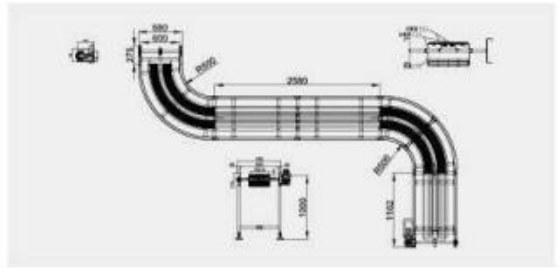
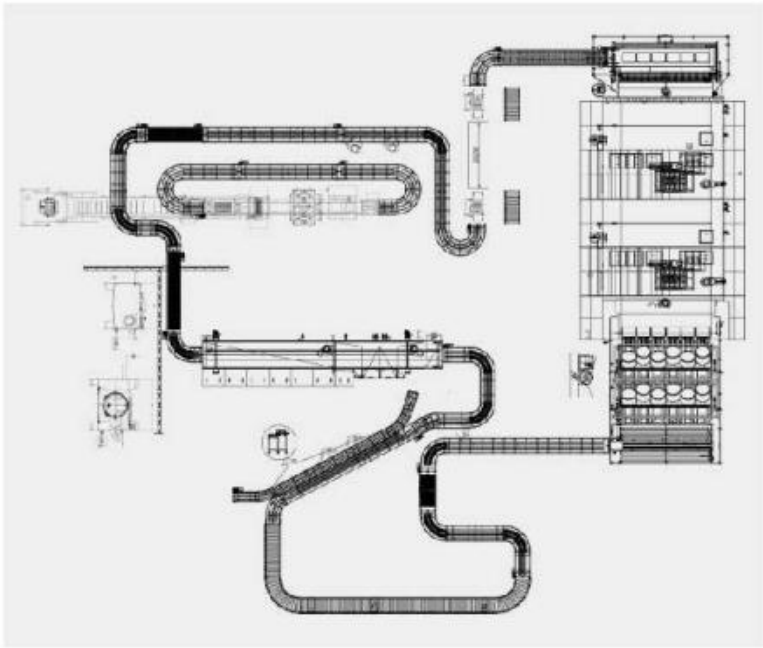

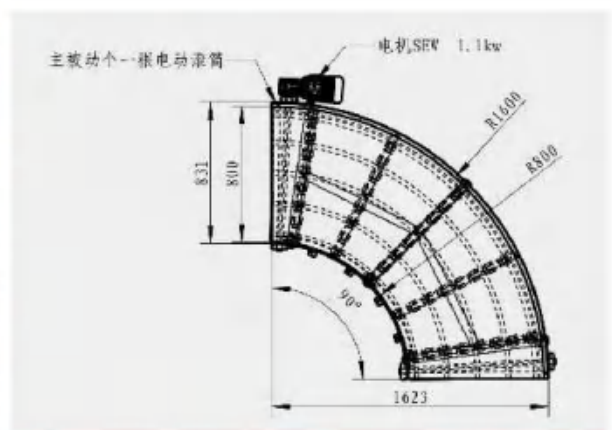
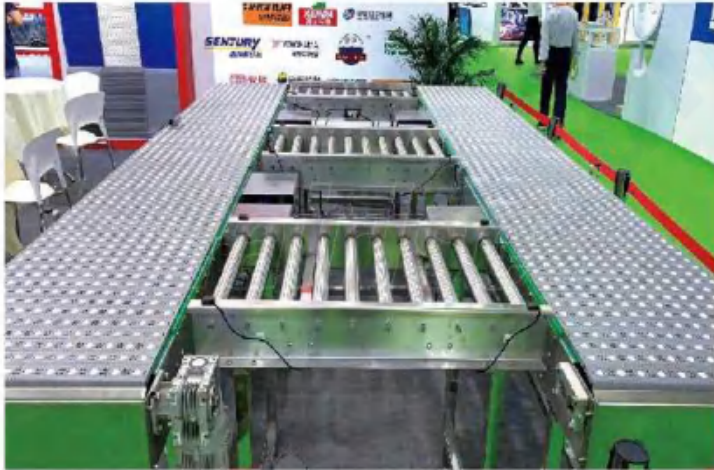
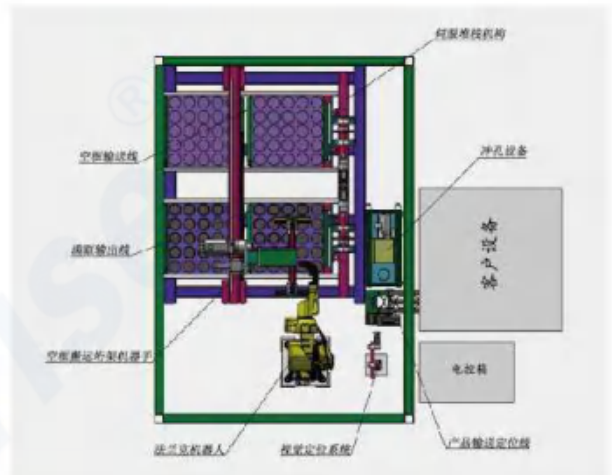
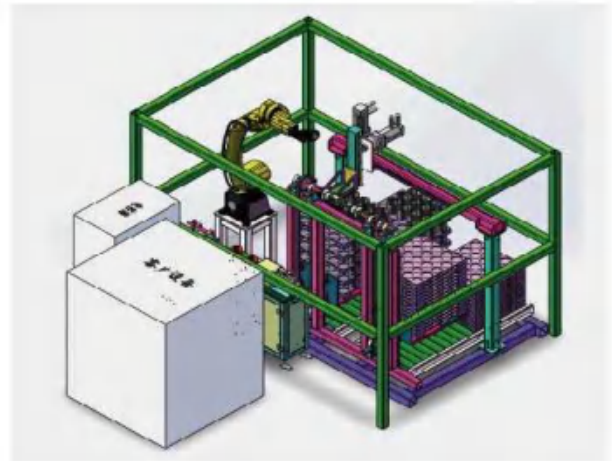
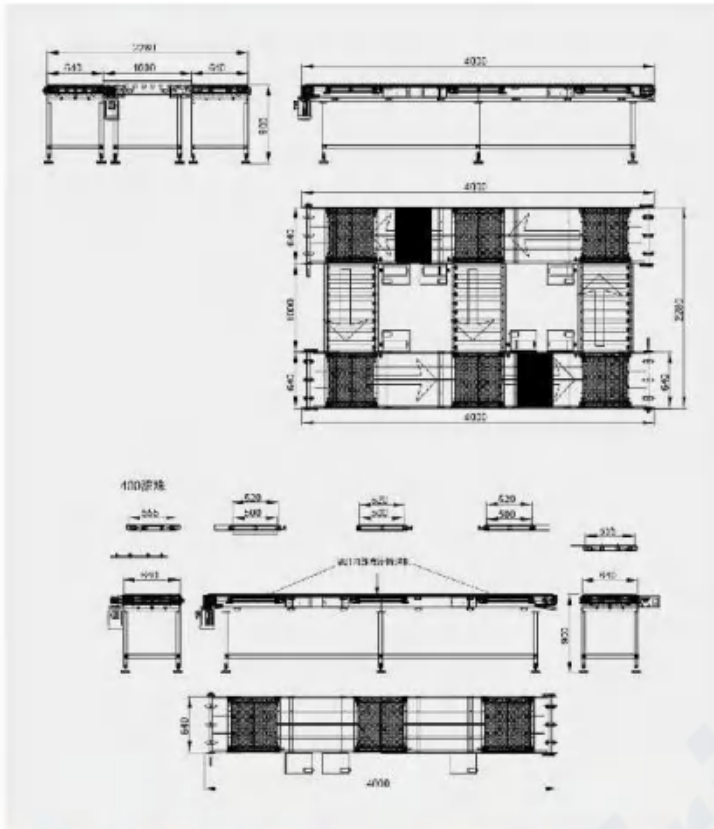

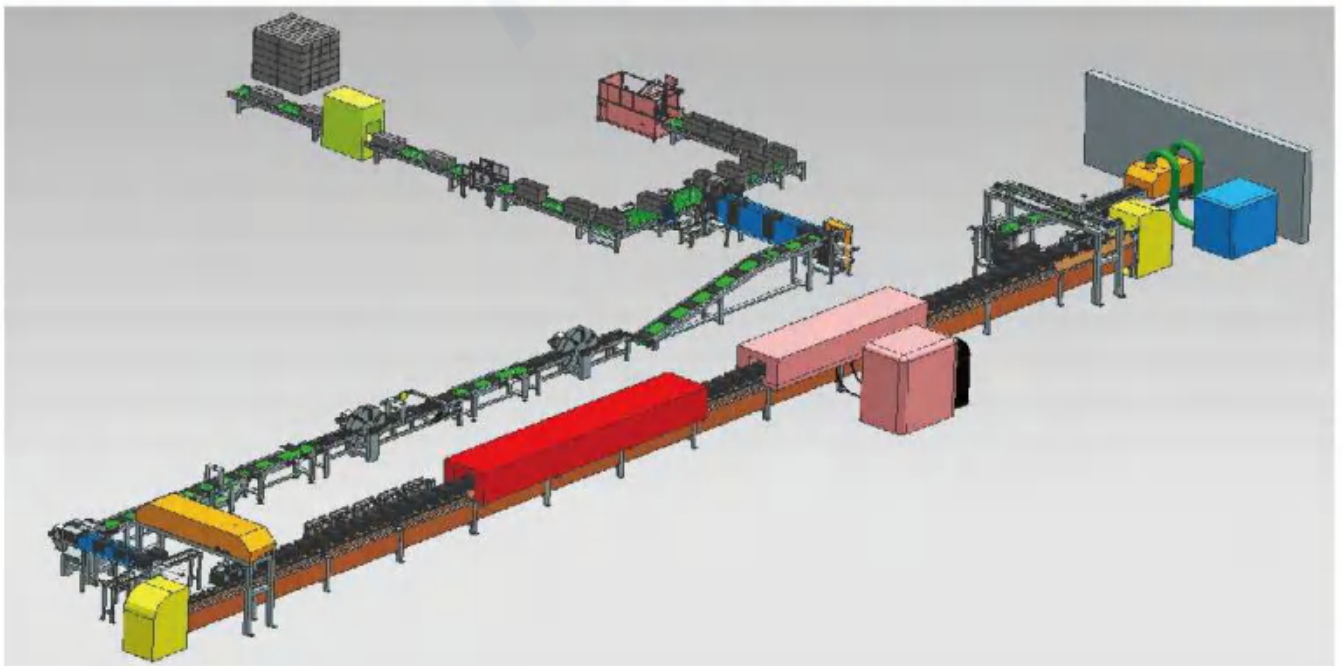
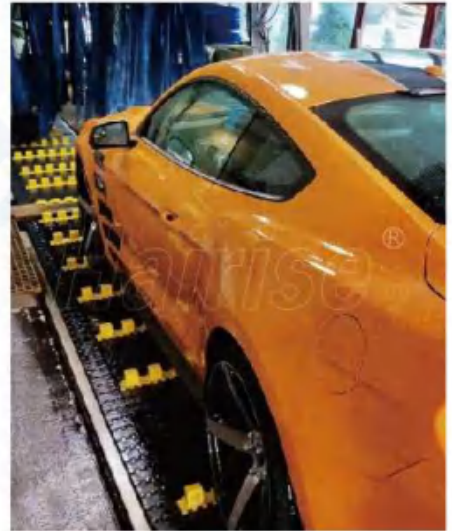
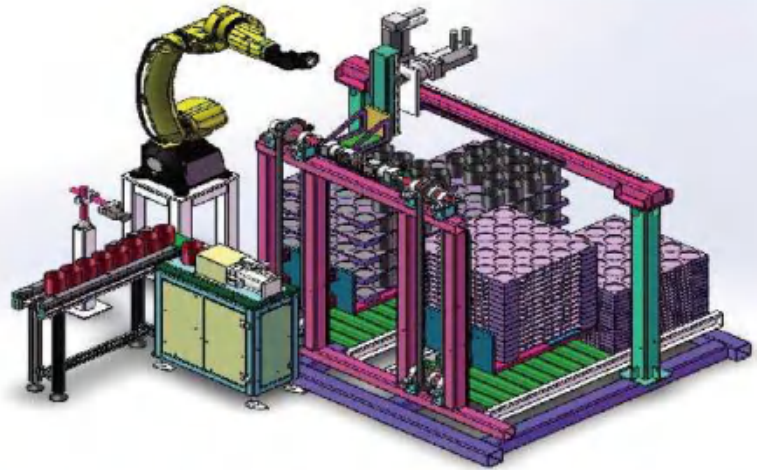
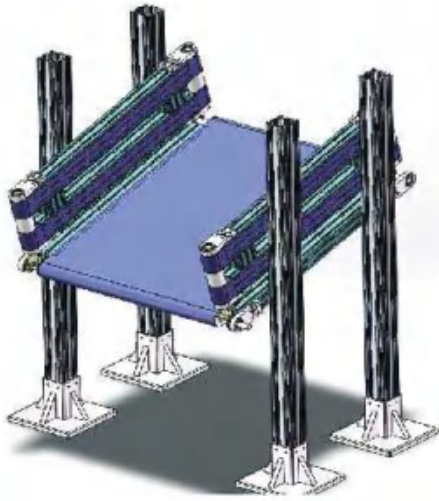

PLASTIC FLEXIBLE CHAIN CONVEYOR 柔性链输送机

Normally, flexible chain conveyor is made of Aluminium profile and flexible plastic chains. Thanks to the small radius and standard components, it doesn't need too much room. It's also easy to assemble and install. Available width for single rail: 65mm/85mm/105mm/140mm/175mm. For larger width, more rails is a good choice. It's usually used for food & beverage industry and production line.

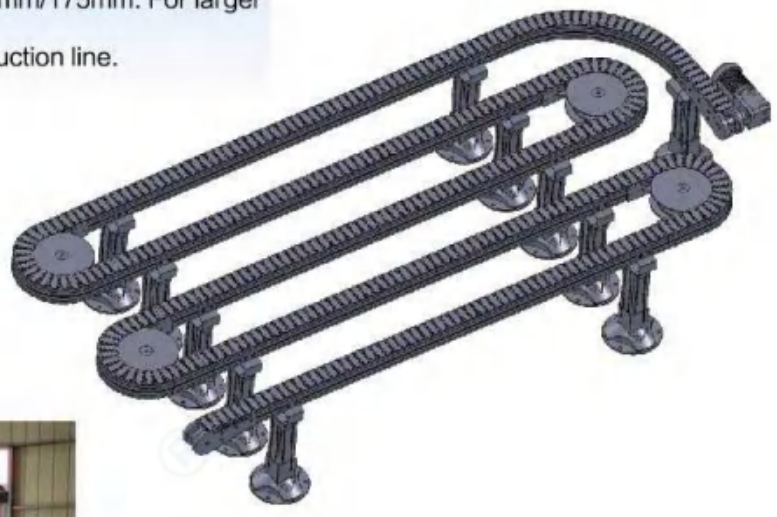

Flexible Chain System



90 Degree Type



Double Rail



输送设备 Chain Conveyor

Conveyor frame:SS304 / SS316 / Carbon steel / Aluminium
Belt material:POM/PP, food grade
Belt width:85mm-3500mm
Dimension:Customized
Application:Food & beverage industry, Logistics industry,tyre industry, Battery, Packaging & Cans, Daily chemicals industry,Tobacco, Corrugated industry and etc.

Straight Type



Small System



90 Degree Curved Type



Inclined Type



With Flight and Side Wall



Rubber top modular belt with friction
It's popular to used for conveying heavy
duty products,
such as cartons, bottles and sacks.



Inclined Type



Double-Deck Type



90 Degree Curved Conveyor

Standard Width:600mm/800mm

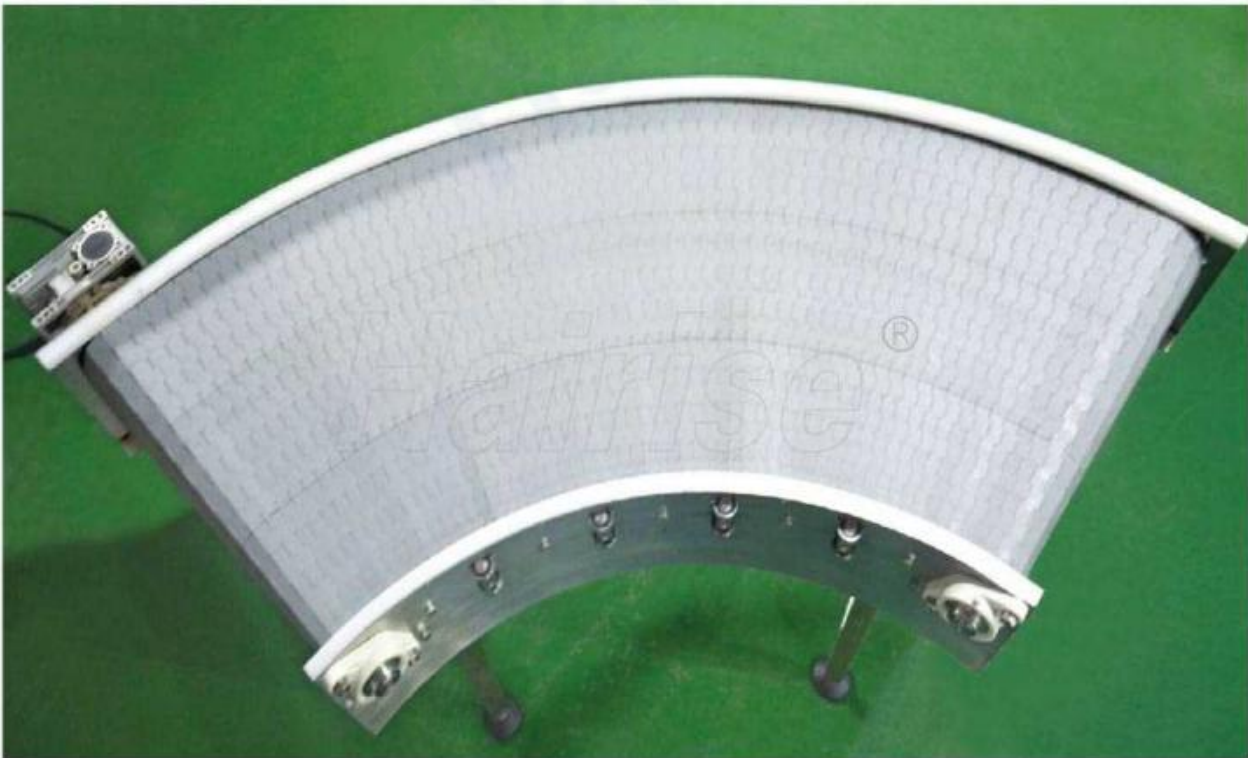

Conveyor frame:SS304/SS316/Carbon steel/Aluminium
 Belt material:PVC, PU (food grade)
 Belt width:100-2500mm
 Dimension:Customized
 Application:Food & beverage industry, Logistics industry, Packaging & Cans, Daily chemicals industry, Tobacco and etc.

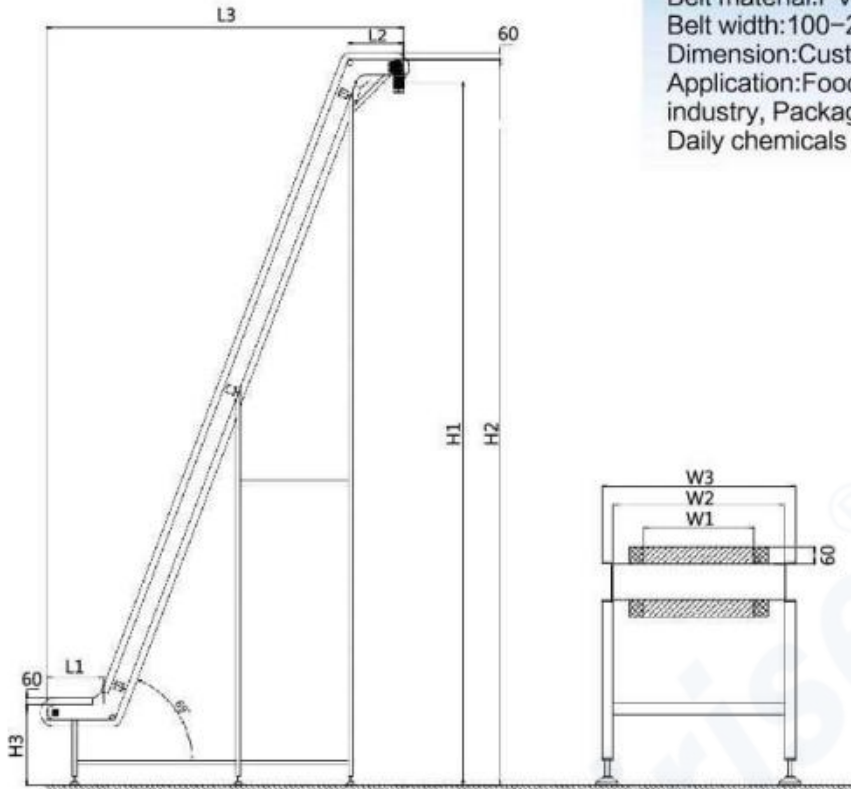

Inclined Type
 With Baffle and Flight



Straight Type



Aluminium Frame



90 Degree Curved Covneyor
Normal width:500-900mm



Conveyor frame:SS304 / SS316 / Carbon steel
Belt material:SS304 / Carbon steel
Belt width:150-2000mm
Dimension:Customized
Application:Food & beverage industry, Logistics industry, Packaging & Cans, and etc.



90 Degree Curved, Powered Conveyor



Logistics Industry



Without Power

Conveyor frame:SS304/SS316/Carbon steel
 Belt material:POM, food grade
 Belt width for single rail:82.6-406mm
 Dimension:Customized
 Application:Food & beverage industry, Packaging & Cans industry, Daily chemicals industry, Tobacco and etc.



Conveyor frame:SS304/SS316/Carbon steel
Belt material:SS304/carbon steel
Belt width for single rail:
82.6-190.5mm (Metal chain conveyor);
100-1500mm (Wire mesh belt conveyor)
Dimension:Customized
Application:Food & beverage industry,
Packaging & Cans, High temperature conveying,
Daily chemicals industry, Tobacco and etc.



Wire Mesh
Belt Conveyor



Metal Chain Conveyor
Pretty Popular in Glass
Bottle Industry

Food Industry-Meat (Beef&Pork/Poultry/Seafood...) 肉类 (牛肉和猪肉/家禽/海鲜...)

Meat Processing



Detecting



Food Industry-Meat (Beef&Pork/Poultry/Seafood...) 肉类 (牛肉和猪肉/家禽/海鲜...)

Frozen



Shrimp Process



Bottle Water Processing



Production Line

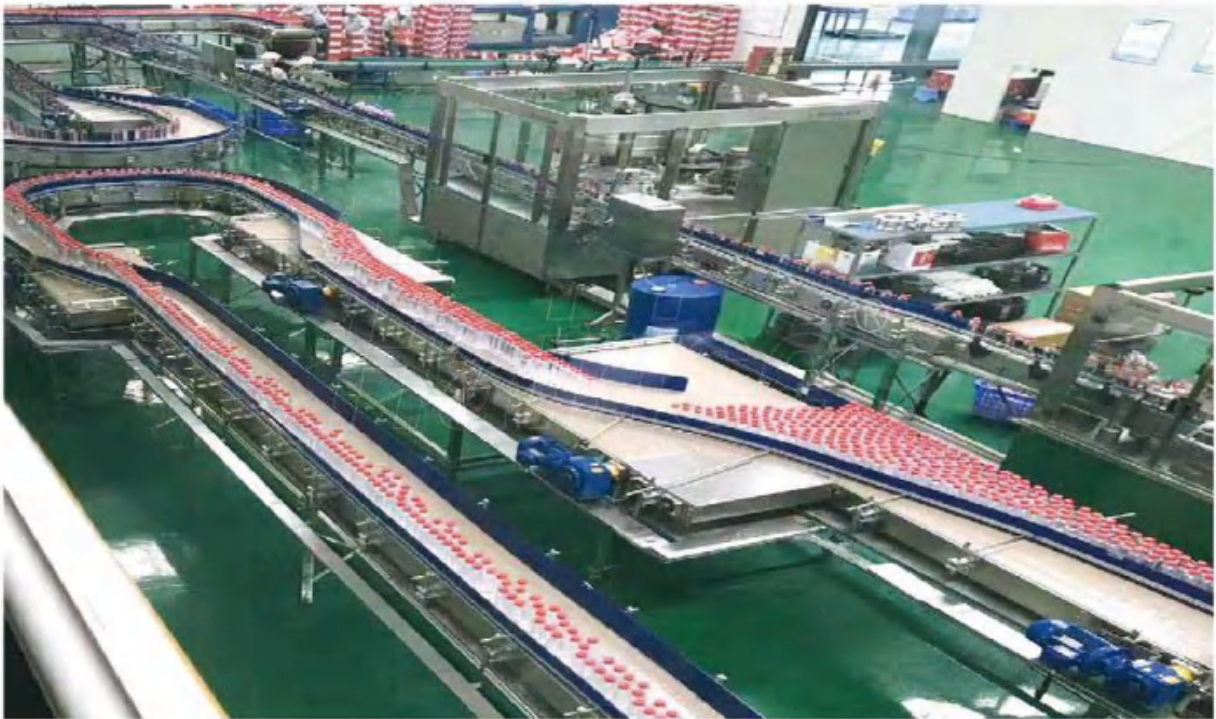

Conveyor frame:SS304 / Carbon steel
Belt material:PP / POM
Belt width:400-2600mm
Belt code:Har400 roller top
Har600 roller top
Har900 flat top / flush grid





Plastic Chain Type 链条式

Conveyor frame:SS304 / Carbon steel
Belt:SS304 / carbon steel base chain +
Plastic chain
Belt width:304.8mm/406mm/457.2mm
Height:Customized
Application:Food & beverage industry,
Logistics industry,
Packaging & Cans and etc.

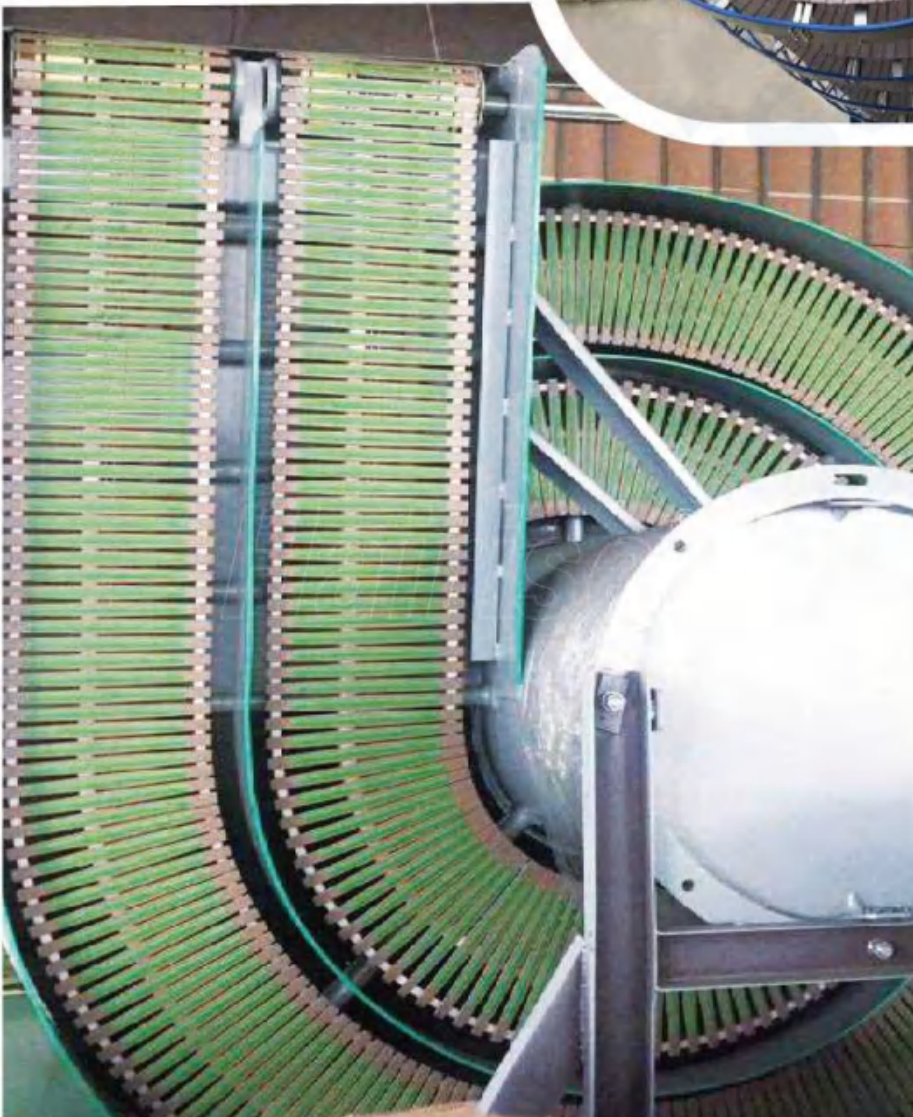

Modular Belt Type 网链式

Conveyor frame:SS304
Belt material:Plastic
Belt width:350-800mm
Dimension:Customized
Application:Food industry

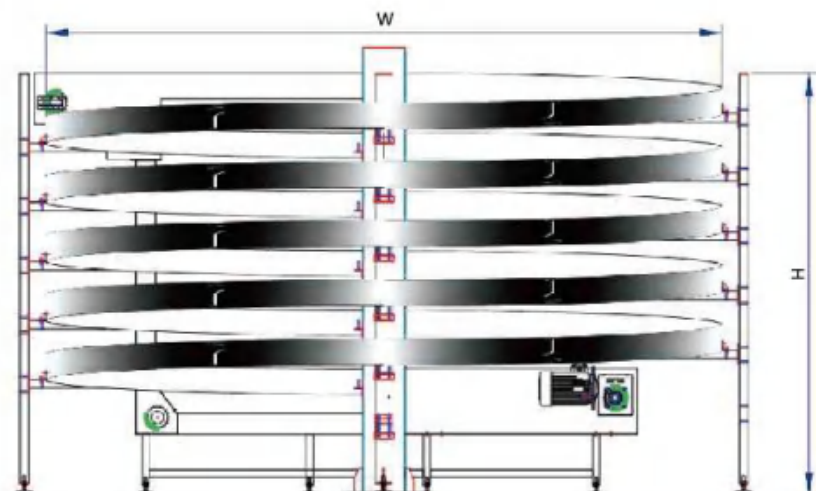

Roller Type 滚筒式

Conveyor frame:SS304
Belt:Roller
Belt width:300-800mm
Dimension:Customized
Application:Food & beverage industry,
Logistics industry,
Packaging & Cans and etc



上下空间包装生产线 Packaging Production Line

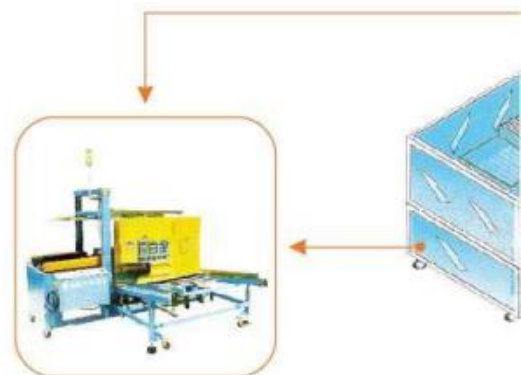

全自动开箱机
Auto Case Erector



螺旋输送机
Spire Lifter

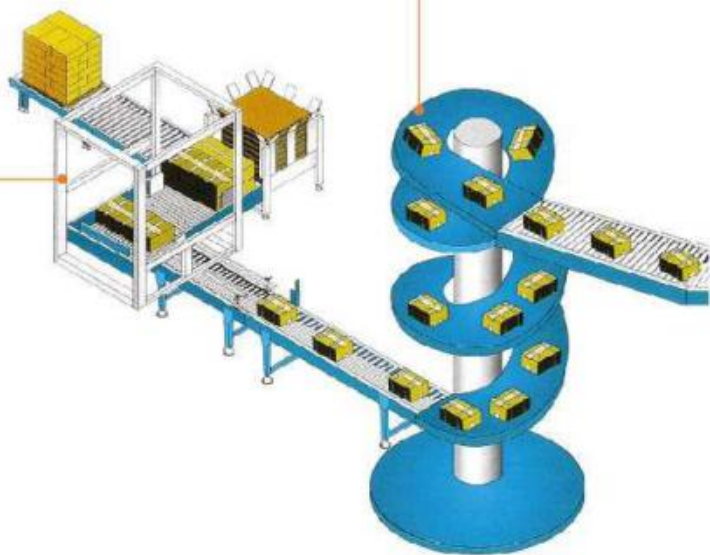
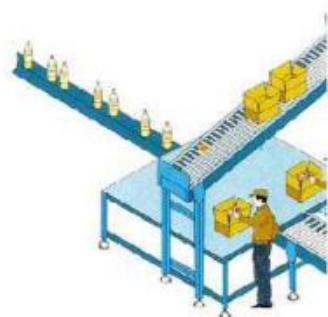

全自动码垛机
Automatic Palletizer

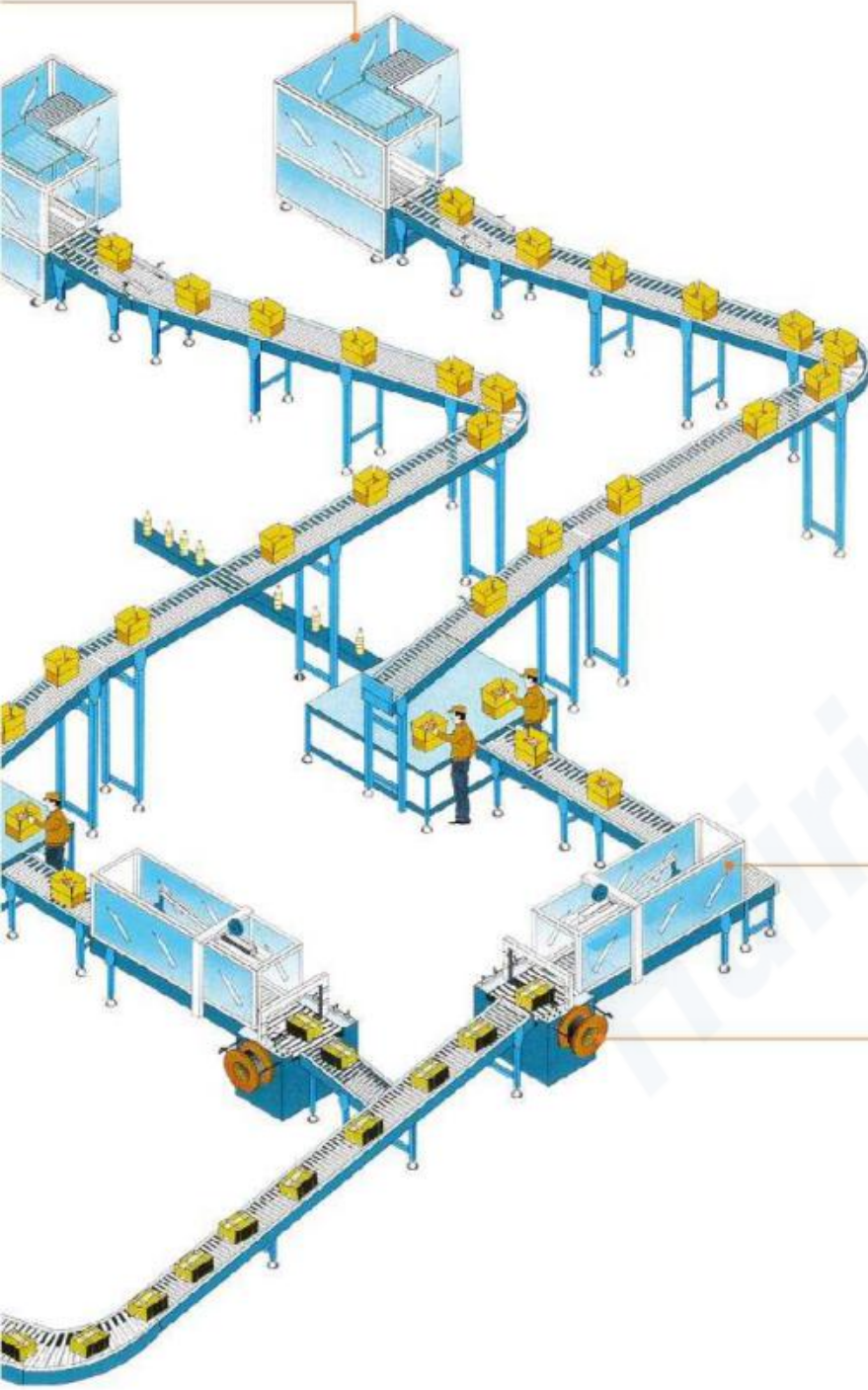

全自动折盖封箱机
Automatic Folded Carton
Sealing Machine



全自动无人化打包机
Auto Unmanned Strapping Machine

瓶装产品裹包式包装生产线 Bottle Packaging Production Line

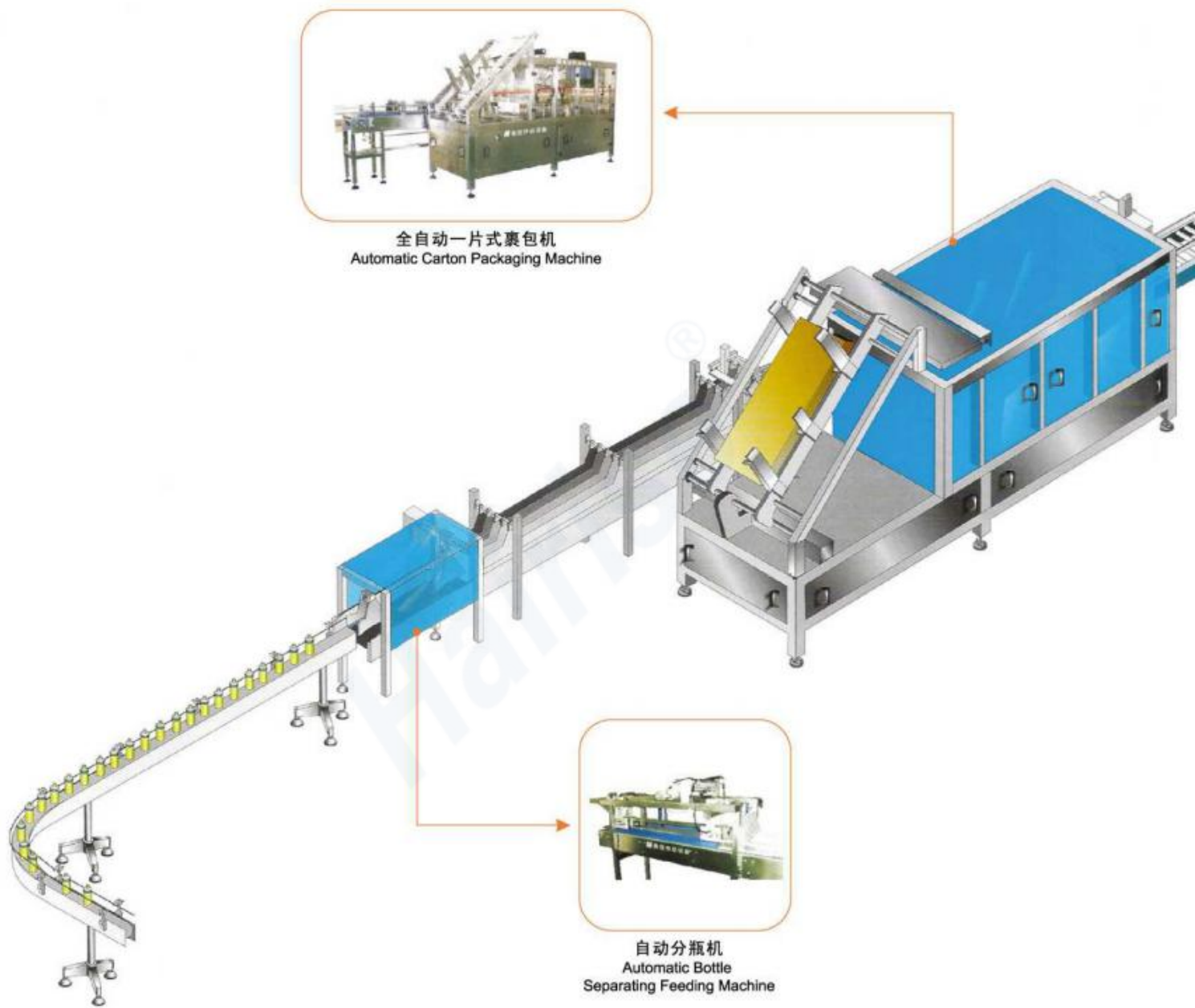

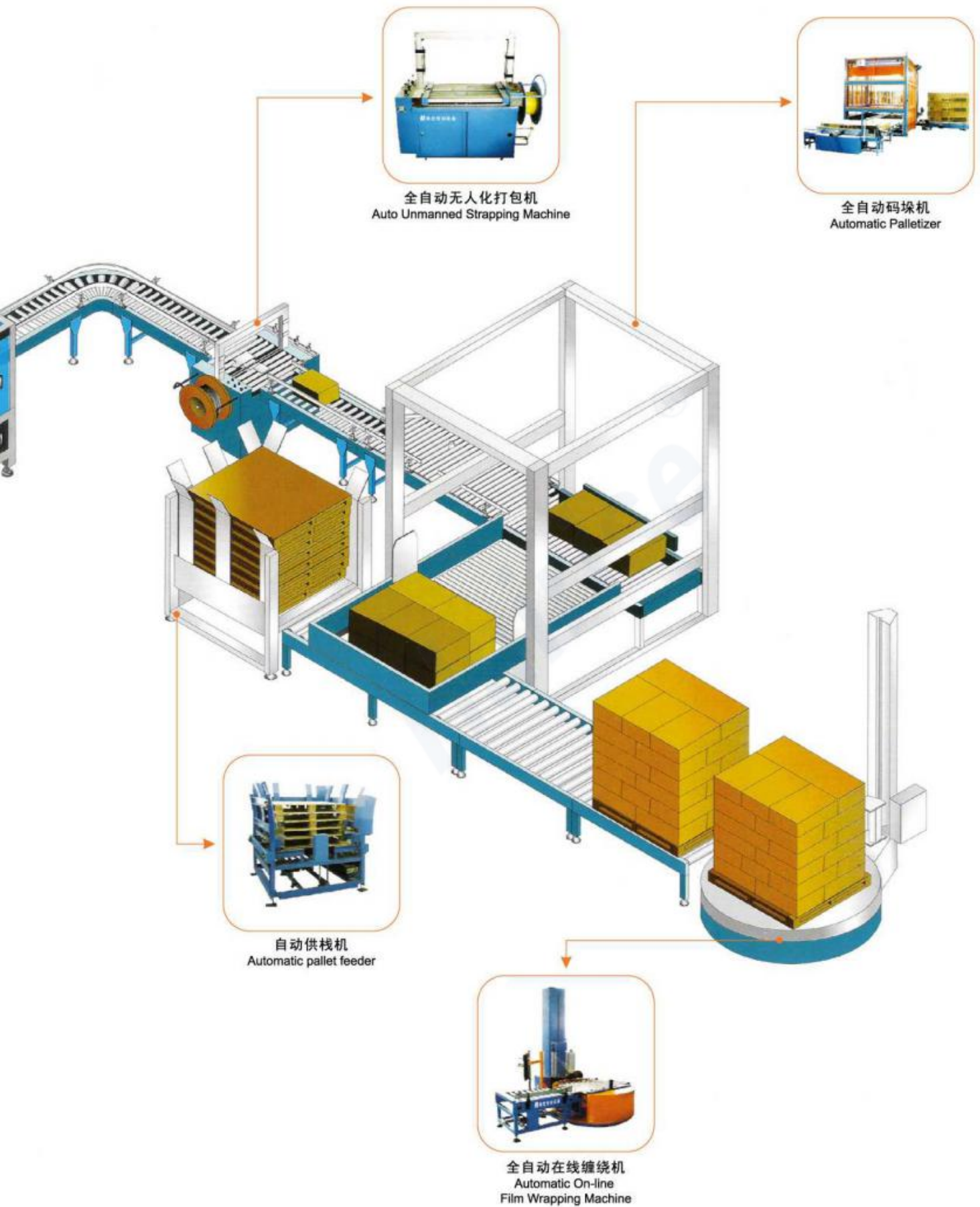

随时恭候垂询，为您提供切实可行的解决方案

我们提供专家建议、质量解决方案和本地服务，
满足您在输送带方面的所有需求。

上海奥佳传动设备股份有限公司

Shanghai All-ka Transmission Equipment Shares CO.,LTD

慕佳自动化科技(上海)有限公司

Mujia Automation Technology (Shanghai) CO.,LTD

总部：上海市松江区莘砖公路668号A座2102
Head Office: Room 2102, No.668, Xinzhuan Rd,
Songjiang Dist, Shanghai, China
Tel: 86 (0)21 67636993 Fax: 86 (0)21 51687578
Web: www.aojiash.com www.modular-belt.com
E-mail: aojia@aojiash.com

北京分公司

地址：北京市怀柔区南大街2号金桥国际
电话：010-61604401 61604406
传真：010-61604402 邮编：100400

武汉分公司

地址：武汉市汉阳区龙阳大道58号
人信汇6号楼
电话：027-84799435 84467100
传真：027-84799435 邮编：430051

江苏生产基地

地址：江苏省南通市海安贤园路27号
电话：0513-88606199 88608199
传真：0513-88608199 邮编：226600

成都分公司

地址：成都市金牛区王贾路18号三九绿城
电话：028-83556084 83556342 83556247
传真：028-83556342 邮编：610000

青岛分公司

地址：青岛市市北区哈尔滨路52号
青建太阳岛商务2号楼
电话：0532-80931008
传真：0532-80935386 邮编：266034

全国免费服务电话：

400-820-1980